



CONSOLIDATED ANNUAL ACTIVITY REPORT 2021

24 June 2022

In accordance with Article 26 of Council Regulation (EU) No 2021/2085 and with Article 23 of the Financial Rules of EU-Rail.

The Europe's Rail Joint Undertaking (EU-Rail) became the legal and universal successor of the Shift2Rail Joint Undertaking (S2R JU or S2R). Hence, EU-Rail has succeeded in the management of the S2R JU Research and Innovation Programme.

However, in this report, references may still be made to S2R Programme, S2R Other Members, S2R R&I, S2R Regulation, S2R JU, S2R etc. to identify all the activities and governance inherited by EU-Rail and related to the former S2R JU.

Contents

- FACTSHEET 4
- EXECUTIVE SUMMARY..... 9
- INTRODUCTION 24
- THE JU’S APPROACH TO MANAGING THE CHALLENGES OF THE PANDEMIC..... 27
- 1. IMPLEMENTATION OF THE ANNUAL WORK PLAN 2021 28
 - 1.1. Key objectives 2021 and associated risks..... 28
 - 1.2. R&I activities: the S2R Programme 31
 - 1.3. Call for proposals and grant information 34
 - 1.3.1. Progress against KPIs / Statistics (Annex C) 35
 - 1.3.2. Evaluation: procedures and global evaluation outcome, redress, statistics 36
 - 1.3.3. Activities carried out in Grant Agreements..... 38
 - 1.4. Towards delivering the S2R Programme 45
 - 1.4.1. IP1 Cost-efficient and Reliable Trains, including high-capacity trains and high-speed trains 49
 - 1.4.2. IP2 Advanced Traffic Management and Control System 64
 - 1.4.3. IP3 Cost-Efficient and Reliable High-Capacity Infrastructure..... 85
 - 1.4.4. IP4 IT Solutions for Attractive Railways Services 100
 - 1.4.5. IP5 Technology for Sustainable and Attractive European Rail Freight 117
 - 1.4.6. CCA Cross Cutting Activities 137
 - 1.4.7. IPx activities - Disruptive Innovation and Exploratory research 148
 - 1.5. Operational calls for tenders and prizes 155
 - 1.6. Dissemination and information about projects results..... 157
 - 1.7. Operational budget execution 159
 - 1.8. In-Kind Contributions 161
 - 1.8.1. Europe’s Rail in-kind Contributions..... 161
 - 1.8.2. S2R in-kind Contributions..... 161
 - 1.9. Synergies with the Union Programmes, Funds and national funded R&I 168
 - 1.10. Launch of Calls for Proposals and Tenders during 2021 169
- 2. SUPPORT TO OPERATIONS 170
 - 2.1. Communication activities 170
 - 2.1.1. Events 174
 - 2.1.2. Communication 183
 - 2.2. Legal and financial framework 187
 - 2.3. Budgetary and financial management 188
 - 2.4. Procurement and contracts..... 190
 - 2.5. IT and logistics 191
 - 2.6. Human Resources..... 192
 - 2.7. Data protection 193
- 3. GOVERNANCE..... 194
 - 3.1. Governing Board (GB)..... 194
 - 3.2. Executive Director (ED)..... 196
 - 3.3. States Representatives Group (SRG) 196
 - 3.4. Scientific Committee (SC)..... 197
 - 3.5. Innovation Programme’s Steering Committees (SteCos)..... 198
 - 3.6. European Union Agency for Railways (ERA)..... 198
- 4. INTERNAL CONTROL FRAMEWORK 200
 - 4.1. Financial Procedures 200
 - 4.2. Ex-ante Controls on operational Expenditure 201
 - 4.3. Ex-post Control of Operational Expenditure and Error Rates Identified 202

4.4.	Control efficiency and cost-effectiveness	206
4.5.	Audit of the European Court of Auditors	208
4.6.	Internal Audit	209
4.7.	Risk management and conflict of interest	210
4.8.	Anti-Fraud Implementation and Indicators.....	211
4.9.	Compliance and effectiveness of Internal Control.....	213
5.	MANAGEMENT ASSURANCE	215
5.1.	Assessment of the Annual Activity Report by the Governing Board.....	215
5.2.	Elements supporting assurance	215
5.3.	Reservations	215
5.4.	Overall conclusion	215
6.	DECLARATION OF ASSURANCE.....	216
7.	ANNEXES.....	217
	ANNEX A Organisational structure of EU-Rail	218
	ANNEX B Establishment plan.....	219
	ANNEX C Indicators and Scoreboard of KPIs	221
	TABLE I - Horizon 2020 Key Performance Indicators common to all JUs.....	221
	TABLE II - Indicators for monitoring H2020 Cross-Cutting Issues common to all JTI JUs	227
	TABLE III - Key Performance Indicators specific for EU-Rail.....	234
	TABLE IV – Initial Estimation – Release 4 - of the Key Performance Indicators of the Shift2Rail Programme.....	237
	ANNEX D Annual accounts	241
	ANNEX E Overview of publications and events.....	244
	ANNEX F LIST OF ACRONYMS	264
	ANNEX G List of members pertaining to the Shift2Rail Joint Undertaking until 29/11/2021	267
	ANNEX H - FACTSHEET OF THE FORMER S2R JU	268
	ANNEX I List of Founding Members of the Europe’s Rail Joint Undertaking	271

FACTSHEET

<p>Name</p>	<p>Shift2Rail Joint Undertaking (hereinafter S2R JU or S2R) Europe’s Rail Joint Undertaking – as of 30/11/2021 (hereinafter EU-Rail)</p>
<p>Objectives¹</p>	<p>EU-Rail is an autonomous body with its own legal personality. It is an institutional European partnership as per Article 187 of the Treaty on the Functioning of the European Union dedicated to managing and coordinating mission-oriented R&I activities for a major transformation in rail systems in Europe.</p> <p>The general objectives of EU-Rail are to:</p> <ul style="list-style-type: none"> (a) contribute towards the achievement of the Single European Railway Area; (b) ensure a fast transition to more attractive, user-friendly, competitive, affordable, easy to maintain, efficient and sustainable European rail system, integrated into the wider mobility system; (c) support the development of a strong and globally competitive European rail industry. <p>The main task of EU-Rail is to deliver a high-capacity integrated European railway network by eliminating barriers to interoperability and providing solutions for full integration, covering traffic management, vehicles, infrastructure and services, aiming to achieve faster uptake and deployment of projects and innovations.</p>
<p>Founding Legal Act</p>	<p>Council Regulation (EU) No 642/2014 of 16 June 2014 establishing the Shift2Rail Joint Undertaking (S2R Regulation). The S2R Regulation was repealed by entering into force on 30 November 2021 of the Council Regulation (EU) 2021/20852 of 19 November 2021 establishing the Joint Undertakings under Horizon Europe (hereafter the “Single Basic Act” or the “SBA”). By means of SBA, the EU-Rail was established and became the legal and universal successor of the former S2R JU, which it replaced and succeeded as from that date. In addition, in its first meeting, the EU-Rail Governing Board approved the list of decisions adopted by the S2R JU that will continue to apply for EU-Rail in accordance with Article 174(12) of the SBA³.</p>
<p>Executive Director (ED)</p>	<p>Mr Carlo M. Borghini, as from 16 May 2016, with his mandate extended until 15 May 2026⁴.</p>

¹ As this Report largely takes stock on the activities performed in the context of the S2R Programme inherited by its successor – EU-Rail, it is essential to recall the key objectives pertaining to the S2R partnership:

- a 50 % reduction of the life-cycle cost of the railway transport system (i.e. costs of building, operating, maintaining and renewing infrastructure and rolling stock),
- a 100 % increase in the capacity of the railway transport system,
- a 50 % increase in the reliability and punctuality of rail services (measured as a 50 % decrease in unreliability and late arrivals).

² OJ L 427, 30.11.2021

³ EU-Rail GB decision n° 02/2021

⁴ S2R JU GB Decision n° 02/2021

Governing Board of EU-Rail⁵	European Commission (EC) members:	
	<ul style="list-style-type: none"> • <i>Henrik Hololei, DG MOVE</i> 	
	EC alternates:	
	<ul style="list-style-type: none"> • <i>DG MOVE</i> • <i>DG RTD</i> 	<i>Kristian Schmidt, Rosalinde Van Der Vlies,</i>
	Industry members:	
	<ul style="list-style-type: none"> • <i>ADIF</i> • <i>ALSTOM</i> • <i>ANGELRAIL consortium led by MER MEC</i> • <i>AŽD</i> • <i>CAF</i> • <i>CEIT</i> • <i>ČD</i> • <i>DEUTSCHE BAHN</i> • <i>DLR</i> • <i>eSGR JV</i> • <i>Faiveley Transport</i> • <i>Ferrovie dello Stato Italiane</i> • <i>HITACHI RAIL STS</i> • <i>INDRA-TALGO</i> • <i>Jernbanedirektorate</i> • <i>KNORR-BREMSE</i> • <i>ÖBB</i> • <i>PKP</i> • <i>ProRail-NS Groep</i> • <i>SIEMENS</i> • <i>SNCF</i> • <i>Strukton</i> • <i>THALES</i> • <i>TRAFIKVERKET</i> • <i>Voestalpine Railway Systems</i> 	<i>Luis Fernando López Nicolas Castres Saint Martin Francesco Inzirillo Vladimir Kampik Jorge De Castro Juan Melendez Kryštof Hajn Ralf Marxen Christian Sattler Noemi Jimenez Redondo Roberto Tione Roberto Tundo Antonella Trombetta Jose Miguel Rubio Sanchez Preben Saethre Hans-Christian Hilse Mark Topal Goekceli Jancewicz Zbigniew Karel van Gils Roland Edel Christophe Cheron Tjark de Vries Alberto Parrondo Bo Olsson Jochen Holzfeind</i>
	Industry alternates:	
	<ul style="list-style-type: none"> • <i>ADIF</i> • <i>ALSTOM</i> • <i>ANGELRAIL consortium led by MER MEC</i> • <i>AŽD</i> 	<i>David-Ibán Villalmanzo Resusta Richard French Vincenzo Scarnera Michal Pavel</i>

⁵ The GB of the S2R JU operative until 29/11/2021 had a different composition.

	<ul style="list-style-type: none"> • CAF <i>Imanol Iturrioz Villalba</i> • CEIT <i>Jaizki Mendizabal</i> • ČD <i>Libor Lochman</i> <i>Petr Jindra</i> • DEUTSCHE BAHN <i>Hans-Peter Lang</i> • DLR <i>Michael Meyer zu Hörste</i> <i>Svenja Hainz</i> • eSGR JV <i>David Sanz</i> <i>Jose Solis Hernandez</i> <i>Celestino Martinez</i> • Faiveley Transport <i>Paolo Pagliero</i> • Ferrovie dello Stato Italiane <i>Riccardo Santoro</i> • HITACHI RAIL STS <i>Carlo Crovetto</i> • INDRA-TALGO <i>Alfredo Gonzalez Moreno</i> • Jernbanedirektorate <i>Pal Midtlien Danielsen</i> • KNORR-BREMSE <i>Martin Ertl</i> • ÖBB <i>Bertram Ludwig</i> • PKP <i>Fojud Arthur</i> • ProRail-NS Groep <i>Jeroen Fukken</i> • SIEMENS <i>Jürgen Schlaht</i> <i>Lars Deiterding</i> • SNCF <i>Gilles Quesnel</i> • Strukton <i>Henk Samson</i> • THALES <i>Yves Perreal</i> • TRAFIKVERKET <i>Christer Lofving</i> • Voestalpine Railway Systems <i>Uwe Ossberger</i> <p>Other participants:</p> <ul style="list-style-type: none"> • Carlo M BORGHINI <i>Executive Director of EU-Rail</i> <p>Observers:</p> <ul style="list-style-type: none"> • Josef Doppelbauer (ERA) • Ana Gigantino (ERA) • Ny Tiana Tournier (ERA) • Roland Moser (ERRAC) • David Kupfer (ERRAC) • Angela Di Febbraro (SC) • Sarah Bittner-Krautsack (SRG) • Miroslav Haltuf (SRG)
<p>Other bodies</p>	<p>System Pillar Steering Group Deployment Group States Representatives Group (SRG) Scientific Committee (SC)</p>

	Innovation Programmes' Steering Committees (IP SteCos) ⁶
Staff	23 posts as at year-end 2021 as per the JU Staff Establishment Plan ⁷
2021 Budget	<p>The S2R Programme objectives of 2021 were met with the full commitment of the remaining budget appropriations related to the H2020 funded S2R Programme for the operational activities. This demonstrates that the JU was able to engage the railway sector to an effective resource commitment to progress in delivering the railway system transformation, through an increasingly integrated Programme (despite starting its operations almost two years after the start of H2020 programming period).</p> <p>The Annual Work Plan and budget 2021 was amended on two occasions mainly to address the need to support two main key policy priorities: (1) the last steps of the implementation of the S2R Programme Budget and (2) the transition to the new Research & Innovation (R&I) Programme by using the funds available under the provisions of Article 16(1)2 of the ex-S2R Statutes.</p> <p>The progress achieved and the launch of these additional core activities represented another key step towards the digitalization and automation of the railway system, contributing to delivering sustainable (climate neutral, lifecycle cost efficient, connected, integrated through a system approach) mobility and transport for passengers and supply chain.</p> <p>As a result, the Final Adopted Budget amounted to EUR 13,6 million in commitment appropriations, of which EUR 9,6 million for operational expenditure and EUR 4,0 million for administrative expenditure. In payment appropriations, the Final Adopted Budget was EUR 68,4 million, of which EUR 46,7 million for operational expenditure, EUR 3,6 million for administrative expenditure and EUR 18,1 million of unused appropriations (among which EUR 17,5 million of unused operational budget) not required in the financial year.</p>
Budget implementation	<p>The Budget implementation refers almost completely to the activities of the former S2R JU. The Budget implementation in terms of commitment appropriations is at 100% and, in terms of payment appropriations at 85% (excluding the unused appropriations not required in the financial year). The payment appropriations' implementation is stable in comparison to previous years (82,3% in 2018, 89% in 2019 and 81% in 2020). Following the second AWP and budget amendment and the delay in the submission of some operational and other requests for payment, suspension of activities either due to the quality of technical reports received or in order to obtain complementary elements confirming the achievement of the project results, the JU would not have been able to implement at least EUR 17,5 million of payment appropriations by the end of 2021. This amount was therefore transferred to the unused appropriations in order to be immediately re-inscribed into the payment appropriations of 2022.</p>

⁶ IP SteCos will no longer be in place for the new EU-Rail Programme under Horizon Europe.

⁷ Due to ongoing/pending recruitments, on 31/12/2021 there were 19 staff members including 1 SNE available.

	<p>The implementation of administrative budget was EUR 4,0 million in commitment appropriations and EUR 3,5 million in payment appropriations, respectively representing 100% and 95,3% of budget execution. Applying sound financial management, the JU makes use of multi-annual framework contracts, in particular in Title 2. The Administrative budget corresponds to approximately 5% of the JU Budget (Payment 2021). The Operational Budget was implemented at EUR 9,6 million in commitment appropriations (100%) and EUR 39,4 million (84,5%) in payment appropriations.</p>
Grants	<p>In June 2021, the JU awarded the 2 last grants under the S2R Programme as a result of the 2021 Call launched on 15 April 2021 based on the amended Annual Work Plan 2021. Both topics have been covered. In total, the awarded grants will fund Research and Innovation activities up to EUR 1,77 million against a total value of EUR 2,34 million.</p> <p>Under the former S2R Regulation, it should be noted that the S2R Founding Members other than the Union and the Associated Members (jointly referred to as the “S2R Other Member”) agreed to limit their requests for funding to 44,44% of the total project cost.</p>
Strategic Research Agenda⁸	<p>In the context of EU-Rail, as defined in the SBA, the “Strategic Research and Innovation Agenda” (SRIA) represents the document covering the duration of Horizon Europe that identifies the key priorities and the essential technologies and innovations required to achieve the objectives of the JU. In accordance with SBA Article 86(5), the SRIA of EU-Rail is constituted by its Master Plan⁹.</p>
Call implementation	<p>The AWP 2021 was amended in April 2021 to include an additional new Call for Proposal under the MFF 2014-2020.</p> <p>The award of the 2021 Call took place during the Governing Board meeting of on 22 June 2021.</p>
Participation, including SMEs	<p>3 Small and Medium enterprises (SMEs) participated to the 2021 Call (13,64%); 1 SME was retained for funding (8,33%).</p> <p>The SME represents 9% of the entities selected in the respective project.</p>

The list of Members and the summary factsheet in relation to the former Shift2Rail Joint Undertaking is available in Annex G and H respectively.

⁸ For the S2R JU, in accordance with the S2R Regulation, the strategic research and innovation agenda was represented by its Multi-Annual Action Plan (MAAP) adopted in its latest version in November 2019, by means of the GB Decision N° 9/2019 adopting Part B of the Shift2Rail JU Multi-Annual Action Plan.

⁹ https://shift2rail.org/wp-content/uploads/2022/03/EURAIL_Master-Plan.pdf

EXECUTIVE SUMMARY

2021 marked the start of a new institutionalised European partnership, Europe's Rail Joint Undertaking (or EU-Rail) officially established on 19 November 2021 by Council Regulation (EU) 2021/2085. It is the new institutionalised European partnership on rail research and innovation established under the Horizon Europe programme (2021-2027) and the universal successor of the Shift2Rail Joint Undertaking. This milestone followed after an intense year of preparatory activities conducted with the European Commission services, including the launch of expression of interest to become a Founding Member of the new JU and the preparation of the JU Master Plan.

The vision of EU-Rail is to deliver, via an integrated system approach, a high capacity, flexible, multi-modal, sustainable and reliable integrated European railway network by eliminating barriers to interoperability and providing solutions for full integration, for European citizens and cargo.

This partnership aims to accelerate research and development in innovative technologies and operational solutions. This will support the fulfillment of European Union policies and objectives relevant for the railway sector and the competitiveness of the rail sector and the European rail supply industry. In this way, EU-Rail will accelerate the penetration of integrated, interoperable and standardised technological innovations necessary to support the Single European Railway Area (SERA).

EU-Rail builds upon the results and activities carried out by its predecessor, the S2R JU, which was established as a public-private partnership under the Horizon 2020 Framework Programme¹⁰ to manage and coordinate mission-oriented Research and Innovation (R&I) activities for a major transformation in rail systems in Europe.

The S2R strategic objectives and targets remain more than valid also within the framework established by the new "Sustainable and Smart Mobility Strategy" adopted by the European Commission on 9 December 2020¹¹.

2021 activities, those related to S2R Programme as well as those aimed at launching EU-Rail, have continued to be impacted by the Covid-19 pandemic crisis. During such critical periods, rail continued to demonstrate its role as the backbone of the European economy: in a multimodal approach, it has ensured the transport of goods (from food to protective and critical equipment), supported the management of sanitary critical transfers but also continued meeting the needs of citizens (to commute to work, to cover essential travel reasons). This thanks to the rail workers and the innate strengths of rail.

According to CER, the pandemic remains dire in the whole rail industry, and particularly in international passenger services, with the losses suffered by the whole passenger sector from the beginning of the pandemic until end June 2021 amounting to EUR 39 billion. Passenger numbers are dramatically low, more for cross-border traffic, with 2020 total turnover losses estimated by CER at EUR 24 billion for passenger services (-42%) and at EUR 2 billion for cargo (-2%) compared to 2019 values. Especially for rail passenger services, including urban transport, health safety expectations will have to be considered and managed also in the future.

¹⁰ Regulation (EU) No 1291/2013 of the European Parliament and of the Council of 11 December 2013 establishing Horizon 2020 - the Framework Programme for Research and Innovation (2014-2020), OJ L 347, 20.12.2013 and Council Decision (EU) No 2013/743/EU of 3 December 2013 establishing the specific programme implementing Horizon 2020 (2014-2020), OJ L 347, 20.12.2013, p. 965.

¹¹ <https://eur-lex.europa.eu/legal-content/EN/TXT/?uri=CELEX%3A52020DC0789>

S2R Programme Status

During 2021, the JU has further progressed in delivering the S2R Programme, although operational activities have been affected by the Covid-19 pandemic, further delaying the programme outputs of about additional 6 months compared to 2020 delays; this in particular due to the increased number of demonstration activities on-site that were active in 2021 (see Section 1.4). The internal control system in place has ensured effective and efficient sound financial management.

In this context, the work of S2R Other Members, other beneficiaries and of the JU staff shall be commended because they have collectively and individually ensured the progress of the research and innovation activities in such complex conditions, not only with paperwork or lab developments but with concrete demonstration activities on the rail network, whenever possible.

This AAR is impregnated with the achievements of the S2R programme and of many other R&I activities performed around Europe. The JU's projects progressed towards delivering higher TRL levels and prepare for Technological Demonstrators that will be presented at InnoTrans 2022.

The ongoing projects have been affected in different ways by the COVID-19 pandemic. Although projects at lower TRL levels or where collaboration was possible via digital communication progressed largely in line with their planning, projects requiring collaborative activities in situ at different sites in Europe suffered from delays due to different limitations.

Since the early months of the pandemic, the Programme Team has worked with the S2R Project Coordinators to establish a detailed risk analysis and identify mitigation actions as early as possible.

By the end of 2021, the S2R Programme reached pivotal milestones in term of Programme implementation:

- almost all S2R resources are committed for the Programme activities and all planned IPs/CCA related activities are running in granted projects,
- on average, almost 75% of the Programme has been realized in view of reaching the TRL6/7 operational demonstrations planned for conclusion during 2023. In total, it is estimated that the Total Value of the activities performed in 2021 amounts to EUR 123.5 million, of which EUR 113.6 million delivered by the Members other than the European Union (hereinafter S2R Other Members).

During 2021, the JU assessed its R&I activities through a third Control Gate exercise¹². This exercise took into account the deliverables and reports submitted in the context of the Annual Review of the active Projects coordinated by the S2R Other Member. The JU also ensured through this process that the recommendations made during the previous Control Gate Assessment had been properly applied. The overall result is that the Programme benefited from such feedback, built upon also external expertise.

This Programme assessment allowed the JU to confirm that overall, the progress of the activities has been in line with the expectations. In addition, the system approach activities within IPx allowed providing additional coherence and consistency between the interdependencies of the implementing Projects. Only few TDs show delays compared to the initial scheduling, mostly due to availability of

¹² In accordance with the procedure set in the S2R Governance and Process handbook, transparently published on the S2R website: https://shift2rail.org/wp-content/uploads/2021/03/S2RJU-Governance-and-Process-Handbook_20200303_v2.0.pdf

resources and external factors. In such cases, the JU has requested the concerned Project Teams to put in place the necessary mitigating measures.

- **IP1**

In 2021, IP1 TDs progressed unevenly and overall reached 86% of the estimated work planned in 2021. TD1.5 (brakes) and TD1.8 (HVAC) which show a significant progress in term of overall implementation due to the results of their demonstration activities which were accomplished in 2021. Other TDs started their demonstration activities but overall, the progress is more modest as most of the result will come from the finalisation of such demonstrations activities, some not started yet partly due to COVID delays which overall impacted the acceleration of progress expected for 2021. TD1.6 and TD1.7 have only reached an estimated overall completion of 50%. The mitigation measure put into place in 2021 for the moulding tool (externalised via a JU procurement procedure), produced already its effect for TD1.3 (carbody shell) and TD1.6 (doors and access systems) that are although expected to be more visible in the report of 2022, although overall this created some delays.

Some of the most visible R&I results of 2021 are:

- The confirmation of the viability of the Traction SiC technology in particular already from the significant improvement of reliability prediction in suburban environment compared to last year predictions from the lab tests performed within Q2 2021 on the sensors and components. New results will be available next year because of the start in November 2021 of the demonstration activities of regional train demo in France and traction component demonstration on a tramway in Germany.
- interoperability tests of the evolved Wireless Train Backbone (WLTB) shown some limitations of the current V2X implementation when using it for wireless inauguration (unexpected channel congestion due to the high frequency of exchanged periodic telegrams) and therefore adaptation of physical and link layer are needed. Even under COVID19 restriction the Functional Open Coupling (FOC) for HVAC and Doors applications have been deployed and tested, using remote connections between CAF, Bombardier and Siemens laboratories to validate them.
- The prototype built in 2021 of the composite frame for an independent rotating wheel running gear achieves a weight reduction of 46%. For the light-weight axle, a long-time test started in August 2021. The first empirical values from the freight application are available and the weight reduction expectations up to 26% were confirmed.
- The newly developed high SIL braking system, as well as the new generation of adhesion management system, were installed and started testing on an existing EUSKOTREN train in the field.
- In 2021 field test on trains in commercial operation were made for Faiveley HVAC unit mounted on a MIREO regional train from Siemens and for Knorr HVAC unit mounted on a double-deck coach from Bombardier. Results show the viability of such greener solution from both a comfort and energy perspective.

- **IP2**

Significant progress has been reported on all TDs, but TD2.9 due to delays in deliverables submission on the second half of 2021, that on average have reached 94% of the estimated work planned in 2020; all IP2 TDs started have been working on the installation of material for the demonstration activities. It worth noting that TD2.8 on “virtual coupling” concluded its activities by the end 2021, reaching the expected maturity level of TRL3. A full assessment is foreseen with the last project reporting in 2022. The activities of TD2.4 (fail safe train positioning) have not been able to fully recovered from the slow

progress, in term of TD overall advancement, they had last year due to additional activity added in 2020 (on a stand-alone train positioning on top of the previously ongoing works on virtual-balises).

Some of the most visible R&I results of 2021 are:

- European ATO first driverless demonstrator including S2R Adaptable Communication System (ACS) was prepared and presented during the S2R Innovation Days, on 09 December 2021; it proved the concept of the GoA3/4 capabilities of running unattended trains safely as well as demonstrated the capability of transmitting voice and video data using different telecommunication bearers (GSM-R, WLAN and LTE, including 4G).
- The reports of the two ATO GoA2 pilot tests executed in 2020 in the United Kingdom and Switzerland have been delivered in March and June 2021, respectively. These reports were used as the basis for the update of the GoA2 specifications transmitted to ERA. Preliminary GoA3/4 specification has been also delivered in December 2021 and will be made public in the course of 2022.
- The on-board train integrity demonstration preparation activities have added the integration of an OTI-Digital Automatic Coupler (DAC) integrated solution. The collaboration was launched during 2021 with the representatives from the European DAC Delivery Programme (EDDP).

Overall, the results achieved are key milestones for the market uptake of the solutions of this IP and prepare the integration of functions and its specifications in the Control Command and Signalling TSI, in the next revision, currently targeted by 2022, and its further evolution. The work performed in IP2 will show how R&I will feed the new regulatory framework and become a test bed for the future deployment of S2R innovative solutions.

- IP3

In 2021, this IP progressed more evenly compared to previous years, thanks to the mitigation measures implemented by the JU with the related projects, catching few delays although differences between TDs remains. On average IP3 has reached 86% of the estimated work planned in 2021. Next generation of track system (TD3.4) remains although at an estimated overall progress of only 50%. Partly due to the COVID situation for which mitigation measures have been put in place, although mainly resulting in project extensions.

Some of the most visible R&I results of 2021 are:

- The novel rail concept with replaceable rail head has been in service for about one year and exposed to more than 13 MgT with trains that have 31 tons axle loads. The preliminary results show promising results due to the general concept as well as withstand rolling contact fatigue.
- Innovative slab-track solution has been manufactured and transported to the field for installation. This test track includes track section of 50 m and two embedded transition zones of each 14 m. This system will be instrumented and installed during 2022 in the harsh climate of northern Sweden exposed to 31 tons axle load.
- For the next generation track, among other innovative ideas, a design for noise shielding close to the rail has been tested in a laboratory, and the experimental results suggest that the absorptive treatment can result in a reduction of 4-5 dB in rail noise, with an overall noise reduction of 2-3 dB.
- First generation of technology to clean long drainage pipes has been successfully demonstrated in operational environments. Tunnels over 1 km in length are able to be cleaned from deposits under full operations. The solution enables the reduction of long-term costs for functioning drainage pipes by 25 %. First generation of rapid tunnel lining patch repair has

been demonstrated in relevant tunnel environments. The new solution includes semi-automatic form work, fast setting grout and preparation for robot platform mounting. The fully developed technology reduces patch repair time by 50 %.

- The concept of a Solid-State-Transformer based on Multilevel-Inverters, usable for integration in the DC power supply has been developed. The result of the use case “reinforcement of 1,5 kV DC-System by 9kV feed wire” demonstrated an efficiency increase of 5% (A complete change to 9kV increases the efficiency of traction power supply by 10%).
- The implementation of components for crowd management to run the two planned scenarios was concluded positively in Warsaw East Station in 2021.

- **IP4**

Good progress has been reported on all TDs of IP4 and on average they have reached 93% of the estimated work planned in 2021. Most of the issues reported in 2020 have been addressed thanks to the mitigation measures put in place in 2020, and the updated A-REL of the Interoperability Framework showed higher performance and scalability when integrated in the Beta release at IP4 level. This TD back on track increased the confidence on the capability of the Interoperability Framework, although the full performance assessment will only be conducted in 2022 with further services integration and the Final release.

Some of the most visible R&I results of 2021 are:

- the Interoperability Framework and have been tested in the Shift2MaaS pilots (Malaga, Lisbon and Central East Corridor) with seven TSPs that provided Shopping, Booking and Issuing services with 50 users per pilot.
- Modifications in the orchestrators have been made for the introduction of new use cases as multiple travellers’ capabilities (e.g. groups, families, friends travelling together or through different means), that are compatible with all pre-existing features so far developed involving the legacy system of the services tested in the pilots.
- Exploiting of the work carried out in the framework of IP3 a test has been prepared for the Polish Jurata station, making use of 3D models and Digital Twins combined with installed sensors to detect the position of the travellers and overcome the obstacles for indoor navigation.
- Similarly, a cooperation happened in 2021 with IP2 to prepare a test for exchanging new data sets and information about passenger demand and transport supply capacity. In this way prescriptive analytics could be developed for Train Management Supervision Systems (TMS) for real-time timetable optimization based on the demand (demand-based operations).
- The next piloting phases have been also prepared, they are planned for Padua, Athens, Barcelona, Helsinki, Brno, Liberec, Warsaw and Osijek.

- **IP5**

In 2021, the TDs reached an average implementation rate of 83%, and the end of the year was characterised by the conclusion of the freight ATO GoA2 test process with specifications provided to the ERA and lessons learned from this technical demonstrator gathered, but also by conclusion of the R&I works of TD5.5 on Business analytics and implementation strategies. a full assessment is foreseen with the last projects reporting in 2022.

The demonstration activities have been affected by the COVID situation, therefore the IP5 work overall experienced some delays, for which mitigation measures have been put in place, although mainly resulting in project extensions.

Some of the most visible R&I results of 2021 are:

- the performance of the extensive tests in Sweden from January to April 2021 on four DAC systems from 4 different suppliers. The couplers were tested on 9 different wagons.
- Intelligent Video Gate demonstrator was successfully installed in summer 2021 in Sweden. The gate is now under operation delivering train data which is processed by Hitachi and Indra. A second gate has been used in Germany, as a tool to help easy CBM and train dispatching within the freight segment.
- A 2021 result from the R&I activities which is also significant, although not positive, is the discovery that the designed high energy brake disk did not reach enough maturity to be included in the demonstrator, as lab tests did show that the disk was overheating.
- A field test to assess the behaviour of wireless communication technologies in a freight train have been carried out in Sweden.
- The initial concept of the Distributed Power System was demonstrated in February 2021 during various days on a commercial train, confirming that the DPS functions worked as expected, the release times after brake application were much shorter than today and the measured in-train-forces were in the range or lower than the one from the previous simulation.
- **CCA**

The Cross Cutting Activities caught up of the delays of 2020, with 88% level of implementation of planned activities for 2021. All Work Areas progressed well and it worth noting that the R&I activities on WA6 Human Capital ended in 2021; a full assessment is foreseen with the last projects reporting in 2022.

In general, the testing related activities have been although heavily impacted by the COVID pandemic and some planned tests have to be postponed to 2022, in particular for the noise test campaign which explain the overall delay of the WA. Mitigation measures have been put in place, although mainly resulting in project extensions.

Some of the most visible R&I results of 2021 are:

- The confirmation of potential large positive social benefits from the JU innovation improvements for the high speed and regional use cases as well as for the freight case.
- Development of 11 prototypes for Integrated Mobility Management from TRL3 up to TRL5 demonstrating and validating the specified applications and processes for freight related Traffic Management applications. The test results of the prototypes have validated the concepts of the new functionalities supporting improved timetable planning and execution, increased process automation and a higher level of usage of theoretical line capacity.
- On site, tests started for exterior noise tools development, with a successful campaign taking place in Crespin, France during summer 2021.
- The impact of S2R innovations on human capital was also concluded, focusing on future jobs and skills profiles and a qualitative investigation on its importance of competence and staffing composition needed by the sector. A more detailed analysis was carried out on infrastructure related works by the Swedish case; results show that technologies developed in IP3 will lead to increased productivity enabled by improved long-term maintenance planning and operation rather than affecting specific professional roles.

- **IPX**

Linx4Rail 1 & 2 projects activities within the IPX continued to build up on the basis of the System Pillar in the successor of the JU. More particularly, they defined in 2021 an ontology dictionary, built a railway Common Data Model associated to the refinement of the first version of the railway Functional System Architecture delivered in 2020.

The activities of the project TAURO also started, aiming at defining the certification of perception systems (e.g. artificial vision, radar, lidar...) for Safety relevant functions such as lateral signals recognition or obstacle detection. TAURO also tackles the specifications for remote driving and command functionalities for three relevant use cases: Remote driving under ETCS, in freight shunting yards and in depots for tramways.

The JU also continued in 2021 to encouraged PhD researchers through:

- RAILS (Roadmaps for AI integration in the rail Sector) project that investigates aspects related to the adoption of Artificial Intelligence (AI) in rail automation, predictive maintenance and defect detection, traffic planning, and capacity optimization.
- The B4CM (Blockchains as a Distributed Ledger for Attribution of Remote Condition Monitoring Data in Rail) project that is identifying key use cases for blockchain technology within the railways. An initial version of the core framework based around Hyperledger Fabric have been developed on 2021 demonstration use cases in the process of being formalised, and the first of a series of journal papers documenting the findings of the team published.
- Medium voltage DC electric railway systems (MVDC-ERS) project that discovered that both dual active bridge and bidirectional phase-shift full-bridge converters are suitable for a multi-modular input-series output-parallel medium voltage PECT. The two topologies have been implemented and successfully tested in the laboratory in 2021.

The JU also made use of the results of FLEX-RAIL during the definition of the new Programme, in particular from the project recommendations for R&I areas of intervention beyond the S2R MAAP.

Translate4Rail (T4R) project developed a language tool prototype which was tested in 2021 in two Pilots in the border region of Austria and Italy. The tests showed that train drivers and traffic controllers are able to establish effective communication through pre-defined messages by using a language tool. The tool was also tested for free speech recognition including railway jargon where enhancements and further developments would still be needed.

HYPERNEX “Ignition of the European Hyperloop Ecosystem” project includes stakeholders currently active in relation to the development of the hyperloop system in EU. The group examined in 2021 the legislation in place and the available funding opportunities for the development of the hyperloop from a safe, interoperable, and possible intermodal manner. The consortium looked as well as the different scenarios that may arise during the start-up process of Hyperloop.

The inducement prize “S2R-Utrain-Prize-01-2020” (Unique Train) with a total budget of EUR 500.000,00 which was launched in 2020, was subject to evaluation in 2021. It was finally not awarded, because the jury decided not to select any of the applications due to the insufficient quality of the proposed solutions and their demonstration. The S2R Governing Board took note of that and acknowledged the non-award of the prize. The GB as well decided by means of its Decision no. 09/2021 on the respective re-allocation of the budget initially committed to the prize.

S2R Programme Management and MAAP

In terms of Programme Management, 2021 was the second year during which reviews of Lump Sum projects took place. Experience so far has shown that from an operational perspective the use of Lump Sum for members' projects does not only result in an administrative simplification, but also effectively bundles efforts in the project review to focus on the achievements of results. The fact that the proof of concluded work packages (hence related focus on deliverables and milestone approval) provides the basis for the reimbursement of costs has allowed the JU and consortia to focus their efforts in an effective way in order to ensure the delivery of the projects.

2021 Programme Management has been influenced by the need to continue monitoring projects affected by the pandemic restrictions. According to the Commission guidelines, the JU applied a fast track procedure to requests for amendments justified by reasons related to C-19 pandemic, for up to 6 months. The Programme Office supported the projects in implementing mitigating measures as needed. Delays already occurred in 2020 in the submission of deliverables, in particular in the case of the demonstration activities, have been mitigated although further delays happening in 2021. Consequently, some of the running activities are expected to be continuing until the end of 2023, delaying of about 6 months compared to what was reported last year but still well within the JU mandate ending in 2024.

With a holistic approach, the role of the JU is also to ensure that interactions between the various IPs are adequately considered and managed, as technological developments in one part of the system could lead to changes in performance, or even create barriers, in other parts. In addition, cross cutting activities include research on long-term economic and societal trends such as customer needs and human capital and skills, which must be taken into account by the different IPs.

In 2021, additional change requests following the ED Decision on a renewed Programme Governance and Change Management, setting up the ED Programme Board, have been processed, ensuring among other sectorial coherence of initiatives, notably with the integration of relevant concepts from OCORA or RCA into the S2R R&I activities that will deliver concrete demonstrations.

In 2021 progress has been achieved in definition of a rail Functional System Architecture, which is setting the basis for an increase sectorial competence for system of systems modelling in view of enabling and accelerating the integration of new technologies and processes in the rail system.

R&I activities launched in 2021

In June 2021, the JU Governing Board adopted the respective decision approving the results of the 2021 call. This call was launched in April following the adoption of the JU's Amended Annual Work Plan 2021. The proposals received in response to the call covered both topics. Out of the five eligible proposals submitted to the call, two were selected for funding.

Two grant agreements were signed in September 2021. In total, the project proposals selected for funding will result in Research and Innovation activities funded up to EUR 1,77 million against a total value of EUR 2,34 million.

As in the case of the previous years and for the full duration of the Programme, excluding the S2R light-house projects launched by the Commission in 2014, the Founding Members other than the Union and the Associated Members (jointly referred to as the "S2R Other Members") of the S2R JU agreed to a funding rate of maximum 44.44% (this would mean a net 41.44% for an Other Member after having

considered its obligations), demonstrating a strong commitment to deliver the most ambitious Railway R&I Programme for a major transformation to rail systems, once deployed.

In total, twelve participants had their proposal retained for funding in the two topics under the 2021 Call, one of them being an SME. From the geographical perspective, there were participants to the call coming from eleven countries (nine EU Member States, one Associated Country and one participant was from the United Kingdom). Taking into account only the twelve participations in proposals retained for funding, all of those are coming from five EU Member States (see also ANNEX C, Table II).

Given the fact that the 2021 Call was considerably smaller when compared to previous years, both in terms of amount to be granted and number of topics, the structure of geographical representation cannot be objectively compared, e.g. to the Call of 2020.

The inducement prize “S2R-Utrain-Prize-01-2020” (Unique Train) with a total budget of EUR 500.000,00 which was launched in 2020, was subject to evaluation in 2021. It was finally not awarded, because the jury decided not to select any of the applications due to the insufficient quality of the proposed solutions and their demonstration. The S2R Governing Board took note of that and acknowledged the non-award of the prize. The GB as well decided by means of its Decision no. 09/2021 on the respective re-allocation of the budget initially committed to the prize.

The European DAC Delivery Programme under the leadership of EU-Rail

In July 2020, the Governing Board of the JU endorsed the creation of the European DAC (Digital Automatic Coupler) Delivery Programme (EDDP) proposed by the Executive Director, voicing the request of the railway sector. Building upon the outcomes achieved in S2R’s freight related R&I activities (Innovation Programme 5), this Programme brings together the rail sector beyond the Membership to bridge the research work with innovation, including migration planning, towards the deployment of a European DAC solution, built on open and transparent standard specifications. This activity constitutes a major step ahead of the digital rail freight, enabling new operations and services that will contribute meeting the expectations of the Sustainable and Smart Mobility Strategy of the European Commission.

The EDDP integrates, with an independently managed delivery programme (with Mr Mark Topal, CTO of OEBB, appointed as the European DAC Delivery Programme Manager supported by the Co-Manager Jens Engelmann, owner of Railiable), projects like DAC4EU, funded by the German Federal Ministry of Transport and Digital Infrastructure, as well as relevant results from S2R projects under its Innovation Programme 5 on European rail freight.

At the moment of writing of this report, the EDDP can count on almost 300 experts and almost 80 companies and organisation involved across Europe and beyond.

2021 was an important year for the programme as out of the testing carried out during the first two quarters of the year, and following EDDP test specs and EDDP requirements, it was decided to choose the Scharfenberg latch type for the EDDP finalization of specifications. The latching type is a fundamental element of the coupler head, delivering the mechanical coupling / uncoupling mechanism among wagons.



As a result of the JU open call for proposal of 2021, the JU signed the Grant Agreement for the project DACcelerate, which started its activities in June 2021. The project is a Coordinated and Support Action that will support the JU to contribute to key elements like technological assessments of the available solutions for Electric and communication, testing and demonstrations, definition of migration plans, assessing the interfaces with other programmes, business cases, and communication and dissemination, aiming to facilitate the deployment of the DAC in Europe. The project also contributed to the EDDP dissemination activities through S2R Innovation Days and other rail freight specific conferences all through the year (see <https://shift2rail.org/eddp-news/>).

In 2021 several meetings happened with the ERA DAC Topical Working Group with the aim to agree a DAC spec that could be adopted in future TSI, supporting the harmonization all across EU rail network. In parallel DACcelerate has supported preliminary CEN CENELEC meetings to standardize DAC specification. In order to ensure and support the feasibility of the project, a preliminary study over what could be a migration plan for the rail freight fleet has been produced as interim report, which is expected to be complete by the end of year 2022. Meanwhile testing activities still carry on, with the aim to bring more maturity to the DAC project.

Specific contracts were also signed to make use of experts to support specific tasks like the DAC Life Cycle Cost (LCC) analysis and also a study to identify potential sources of financing and potential blend of them so as to support the programme. The results are expected to be available in 2022.

Activities aligned to feed the successor of the S2R JU and with the launch of EU-Rail

The current activities of the S2R JU are progressing towards their demonstrations in 2022 and 2023, paving the way to the R&I activities to be undertaken in the EU-Rail Programme. This will ensure a proper phase out and phase in between the two Programmes. The S2R technological demonstrators are the building blocks of a more systemic railway transformation which is strategically driven by the European Commission's European Green Deal, the Digitalisation Agenda and more recently the Sustainable and Smart Mobility Strategy.

During 2021, the JU further supported the European Commission with the development of the Europe's Rail Master Plan. It has been developed in consultation with all relevant stakeholders, including the JU Candidate Founding Members, and put in an open consultation of 4 weeks; a webinar was held on 19/11/2021.

Following the Council Regulation establishing Europe's Rail adopted in November 2021, in accordance with Article 86 of the Single Basic Act, the Master Plan has been finalised by the Europe's Rail Joint Undertaking together with the Commission, for submission to the GB in 2022 after consultation with the SRG, Council Transport Working Party and European Parliament Transport Committee.

The JU during 2021 also transparently updated the sector and published all information on the progress of the new JU and its key documents in its website, including the provision of Question and

Answers with 4 different releases, in March, May and two in July 2021: <https://shift2rail.org/about-europes-rail/europes-rail-preparatory-activities/>

This preparation work for the EU-Rail Programme has also been an opportunity for the JU to re-assess the maturity level expected to be reached by the different streams of the ongoing S2R Programme, the potential in terms of market take up of R&I outputs and indicate the areas of improvements to foresee for the next generation of R&I projects, the so called “Flagship projects”.

Significant efforts went also into preparing the conditions for the (successful) signature of the letter of Commitment from the Candidate Founding Members, working in alignment and contributing to the definition of the new framework set by the European Commission services for the JUs implementing R&I programmes within the EU funding conditions of Horizon Europe.

The first administrative Governing Board of the Europe’s Rail JU was held on December 21, 2021.

Other activities

Due to the launch of the new EU-Rail as from 30 November, the Staff Establishment Plan remained the one adopted in the context of the S2R JU. The new Staff Establishment Plan was adopted by the Governing Board only on 1 March 2022.

In 2021, the staff turnover continued to be high with some staff members and one SNE leaving the JU. This was attributable, besides other aspects, to the fact that other Union JUs and Agencies are in the position to offer Temporary Agent posts (TA) instead of Contractual Agent posts (CA).

The new Staff Establishment Plan associated to the launch of the new partnership includes new TAs positions in relation to the new role of the JU in the System Pillar and support to policy activities, that are expected to stabilize the structure. The JU avails itself of external competencies and expertise to achieve its operational activities, while activities temporarily outsourcing administrative tasks – to fill gaps or long-term absences – are accounted for in Title 2 of the Budget.

With regard to communication and dissemination activities, JU continued its efforts to promote the activities of the programme during 2021. As it was the case in the previous year, due to the Covid-19 pandemic, many communication and dissemination activities were performed in the online mode. However, the Connecting Europe Express, the flagship campaign of the European Year of Rail, and the S2R Innovation Days were an opportunity to bring S2R innovations to the railway industry, policy makers as well as the general public.

During 2021, the JU also continued its efforts to increase cooperation in Member States as well as with international parties. On 10 June 2021, the JU signed a Memorandum of Understanding (MoU) with the European Committee for Standardization (CEN) and the European Committee for Electrotechnical Standardization (CENELEC). The MoU aims at formalising the already existing close collaboration between CEN and CENELEC, two of the officially recognised European Standardization Organizations, and the Joint Undertaking. Through this agreement, the participating organizations are committed to foster the uptake of innovation in the railway sector and contribute to maintaining the EU as a world leader. Furthermore, the signature of the MoU between the JU and the International Union of Railways (UIC) took place at the UIC General Assembly, on Thursday 8 July. The objective of this MoU is to promote cooperation between UIC and the JU to support the structured implementation of S2R innovative solutions, and to deliver a functional system approach that is suited to the operational needs of the sector and, in particular, the final users.

In addition to the efforts on stakeholder involvement, the JU further continued improving its internal organisation as to provide continuous support to its Members and beneficiaries. Attention was paid to the continuous implementing of the internal control framework and to the assessment and management of risks. The JU cooperated with different stakeholders engaged in audit activities, such as the European Court of Auditors, the Internal Audit Service of the Commission, the Common Audit Service exercised by DG RTD or the external auditors auditing the Annual Accounts of the JU. All of these activities have contributed to the continuous assurance regarding the sound financial management of EU funds managed by the Joint Undertaking.

In 2021, the JU submitted to the European Parliament a follow-up report on Parliament's observations provided in its Resolution related to the decision on discharge in respect of the implementation of the JU's budget for the financial year 2019. In this follow-up report, the JU explained its way in which it addressed these observations or intends to address them in the following period. In particular, with regard to Intellectual Property Rights (IPR), the JU confirmed in this report, that it would welcome any initiative the Commission might take in introducing a legal framework concerning the IPR in response to the call for such initiative from the European Parliament. With regard to transparency of R&I results financed also with public money, the JU, when implementing its S2R MAAP by means of individual grant agreements, contributes to a simplified public access to these results not only via the EC CORDA system, but also directly via the JU website (https://projects.shift2rail.org/s2r_matrixtd.aspx).

It can be concluded that thanks to the commitment of both S2R Other Member and the Programme Office, 2021 has seen the JU further continuing its important progress towards delivering the Shift2Rail Programme, and, in parallel, important steps were taken enabling EU-Rail to become operational and to start preparing the launch of the new Programme.

European Green Deal, the United Nations Sustainable Development Goals, the Sustainable and Smart Mobility Strategy and the Digital Decade

The European Green Deal was presented in December 2019, setting out a clear vision of how to achieve climate neutrality in Europe by 2050¹³. Transport accounts for a quarter of the EU's greenhouse gas emissions, and still growing. To achieve climate neutrality, a 90% reduction in transport emissions is needed by 2050. As a matter of priority, a substantial part of the 75% of inland freight carried today by road should shift onto rail and inland waterways.

"To transform the EU into a fair and prosperous society, with a modern, resource-efficient and competitive economy where there are no net emissions of greenhouse gases in 2050 and where economic growth is decoupled from resource use." (European Green Deal, p. 2).

Priority areas include accelerating the shift to sustainable and smart mobility: *"Automated and connected multimodal mobility will play an increasing role, together with smart traffic management systems enabled by digitalisation. The EU transport system and infrastructure will be made fit to support new sustainable mobility services that can reduce congestion and pollution, especially in urban areas" (European Green Deal, p. 10).*

¹³ [European Commission \(2019\). The European Green Deal. COM\(2019\) 640 final, Brussels](#)

The European Green Deal is also an integral part of the Commission’s strategy to implement the United Nation’s 2030 Agenda and the 17 Sustainable Development Goals (SDGs).¹⁴ Already the Shift2Rail JU has been reporting on its contribution to the SDGs since 2018 in its Annual Activity Reports. Shift2Rail’s Multi-Annual Action Program sets out key goals to strengthen the role of rail in the transport system, given rail’s inherent advantages in terms of environmental performance, land use, energy consumption and safety.

Shift2Rail’s unique R&I work concretely contributes to the following SDGs, and related sub targets:



SDG 9: Building resilient infrastructure, promote inclusive and sustainable industrialization and foster innovation



SDG 11: Make cities and human settlements inclusive, safe, resilient and sustainable



SDG 12: Ensure sustainable consumption and production patterns



SDG 13: Take urgent action to compact climate change and is impacts

The SDGs are not 17 individual goals, but are strongly interconnected, whereas progress in one goal can unlock progress in another. Shift2Rail’s R&I programme also indirectly contributes to the following SDGs, and related sub targets:



SDG 5: Achieving gender equality and empower all women and girls



SDG 8: Promote sustained, inclusive and sustainable economic growth, full and productive employment and decent work for all



SDG 15: Protect, restore and promote sustainable use of terrestrial ecosystems, sustainably manage forests, combat desertification, halt and reserve land degradation and stop biodiversity loss.

A few Horizon 2020 Key Performance Indicators common to all JUs are aligned with the broader objectives of the SDGs, for example, growth and job creation in participating SMEs or percentage of women participants/coordinators in H2020 projects (Annex C, Table I). The same holds for the Key Performance Indicators specific for the S2R Programme, for example reducing the life-cycle cost of the railway transport system and reducing the negative externalities linked to railway transport (Annex C, Table III). The JU is continuously improving the S2R KPI model data.

¹⁴ [United Nations General Assembly \(2015\). Transforming Our World: The 2030 Agenda for Sustainable Development. Draft resolution referred to the United Nations summit for the adoption of the post-2015 development agenda by the General Assembly at its sixty-ninth session. UN Doc. A/70/L.1. New York](#)

Moreover, the new Sustainable and Smart Mobility Strategy of the Commission, launched in December 2020¹⁵, includes more concrete milestones for the railway sector to enhance a smart and sustainable future. Its underlying Action Plan of 82 initiatives lays the foundation for how the EU transport system can achieve its green and digital transformation and become more resilient to future crises. In particular, it provides the visionary ambitions that the next rail R&I Programme will have to contribute to insofar as possible and notably:

- By 2030 the high-speed rail traffic will increase of 50%; the scheduled collective travel of under 500 km should be carbon neutral within the EU and automated mobility will be deployed at large scale.
- By 2050 rail freight traffic will double; high-speed rail traffic will triple and the multimodal Trans-European Transport Network (TEN-T) equipped for sustainable and smart transport with high speed connectivity will be operational for the comprehensive network.

Additionally, rail transport will also need to be further electrified; wherever this is not viable, the use of hydrogen should be increased. And the roll out of the European Rail Traffic Management System (ERTMS) will be pursued including further efforts to develop train automation, for instance through joint undertakings (JUs).

Further to the topic of “Digital Decade”, the Commission indicated in its Communication of March 2021¹⁶ how digital transformation can improve the ecosystems related to mobility and transport. Digitalisation can improve environmental and cost performance and simultaneously increase safety levels contributing to a higher quality of life. It will be achieved through more advanced levels of automation, faster and more reliable connectivity, and IT enabled profound transformation of the management of mobility services. The public could also benefit from fast internet connectivity for passengers on most stations and lines, user-oriented telematics and facilitated multi-modality.

In this context, EU-Rail and its Programme will strive for speeding up the development and deployment of innovative technologies in railway transport in order to contribute to achievement of the above-mentioned milestones. This will require a significant transformation of the railway sector, addressing long overdue changes in legacy operational processes, systems and governance models, as well as integrating with other transport and mobility solutions for passenger services and cargo logistics.

Besides the efforts made via its R&I Programme, the JU and its staff, to the extent corresponding to the size of the organisation, also strive to contribute to the fight against climate change when conducting the day-to-day business. Those “little things” that the JU applies to be as green as possible include:

- Separating waste in the JU’s premises,
- Suppression of using single-use items (even though due to Covid-19, a balance needed to be applied respecting also the necessary anti-pandemic measures),
- Reducing paper consumption by applying paperless workflows to the extent possible,
- Encouraging staff not to commute to work by car by providing a scheme for reimbursement of public transport cost and arrangements supporting commuting by bike,
- Increased usage of online/hybrid meetings and events to reduce the carbon footprint related to travelling.

¹⁵ [European Commission \(2020\). Sustainable and Smart Mobility Strategy – putting European transport on track for the future. COM\(2020\) 789 final, Brussels](#)

¹⁶ [European Commission \(2021\). 2030 Digital Compass: the European way for the Digital Decade. COM\(2021\) 118 final, Brussels](#)

EU-Rail will also duly consider the energy-efficiency parameters with regard to the foreseen changes of the premises it uses, no matter if the decision expected to be taken in 2022 will be to move to a different building, or to refurbish the currently used premises.

The next sections of this 2021 AAR present in details the achievements, risks and opportunities and evolution of the JU during the past year.

INTRODUCTION

EU-Rail was established by Council Regulation (EU) 2021/2085 of 19 November 2021 establishing the Joint Undertakings under Horizon Europe and repealing Regulations (EC) No 219/2007, (EU) No 557/2014, (EU) No 558/2014, (EU) No 559/2014, (EU) No 560/2014, (EU) No 561/2014 and (EU) No 642/2014 (hereinafter also the “Single Basic Act” or “SBA”), which entered into force on 30 November 2021. In accordance with Article 174(6) of the SBA, EU-Rail is the legal and universal successor in respect of all contracts, including employment contracts and grant agreements, liabilities and acquired property of the Shift2Rail Joint Undertaking which it replaced and succeeded.

EU-Rail is an autonomous body with its own legal personality having its seat located in Brussels, Belgium. It is a institutionalised European partnership as per Article 187 of the Treaty on the Functioning of the European Union dedicated to manage and coordinate mission-oriented Research and Innovation (R&I) activities for a major transformation in rail systems in Europe.

The Vision of EU-Rail¹⁷ is

To deliver, via an integrated system approach, a high capacity, flexible, multi-modal, sustainable and reliable integrated European railway network by eliminating barriers to interoperability and providing solutions for full integration, for European citizens and cargo.

The mission statement of EU-Rail¹⁸ is

“Rail Research and Innovation to make rail the everyday mobility”

In accordance with article 87(1) of the SBA, the members of EU-Rail are the Union, represented by the Commission, and 25 Private Members¹⁹. The Private Members of EU-Rail were selected via an open and transparent process, started with an “invitation to manifest the interest to become Candidate Founding Member of the Transforming Europe’s Rail System European Partnership” on 13 August 2020 and concluded with the listing of 25 entities retained as Founding Members in Annex II of the SBA. The Private Members of EU-Rail signed a Letter of Commitment in accordance with the provisions of the SBA to deliver the contributions established in its Article 89.

The objective of Europe’s Rail Joint Undertaking is to deliver a high-capacity integrated European railway network by eliminating barriers to interoperability and providing solutions for full integration, covering traffic management, vehicles, infrastructure and services, aiming to achieve faster uptake and deployment of projects and innovations. That should exploit the huge potential for digitalisation and automation to reduce rail’s costs, increase its capacity and enhance its flexibility and reliability, and should be based upon a solid reference functional system architecture shared by the sector, in coordination with the European Union Agency for Railways (ERA).

In addition to the General and Specific Objectives established in Chapter 1 of the SBA, EU-RAIL is entrusted with the following:

¹⁷ The former vision as defined for the S2R JU was as follows: “To deliver, through railway research and innovation, the capabilities to bring about the most sustainable, cost-efficient, high-performing, time drive, digital and competitive customer-centred transport mode for Europe.”

¹⁸ The former mission statement as defined for the S2R JU was as follows: “Shift2Rail: moving European railway forward”

¹⁹ In accordance with Article 2(5) of the SBA, “Private Member” means any legal entity established under public or private law that is a member of a joint undertaking other than the Union, participating states or international organisations.

General Objectives

- (d) contribute towards the achievement of the Single European Railway Area;
- (e) ensure a fast transition to more attractive, user-friendly, competitive, affordable, easy to maintain, efficient and sustainable European rail system, integrated into the wider mobility system;
- (f) support the development of a strong and globally competitive European rail industry.

Specific objectives

- (a) facilitate research and innovation activities to deliver an integrated European railway network by design, eliminating barriers to interoperability and providing solutions for full integration, covering traffic management, vehicles, infrastructure also including integration with non-standard national gauges, such as 1520, 1000 or 1668 mm railway, and services, and providing the best answer to the needs of passengers and businesses, accelerating uptake of innovative solutions to support the Single European Railway Area, while increasing capacity and reliability and decreasing costs of railway transport;
- (b) deliver a sustainable and resilient rail system: by developing a zero-emission, silent rail system and climate resilient infrastructure, applying circular economy to the rail sector, piloting the use of innovative processes, technologies, designs and materials in the full life-cycle of rail systems and developing other innovative solutions to guided surface transport;
- (c) develop through its System Pillar a unified operational concept and a functional, safe and secure system architecture, with due consideration of cyber-security aspects, focused on the European railway network to which Directive 2016/797 applies, for integrated European rail traffic management, command, control and signalling systems, including automated train operation which shall ensure that research and innovation is targeted on commonly agreed and shared customer requirements and operational needs, and is open to evolution;
- (d) facilitate research and innovation activities related to rail freight and intermodal transport services to deliver a competitive green rail freight fully integrated into the logistic value chain, with automation and digitalisation of freight rail at the core;
- (e) develop demonstration projects in interested member states;
- (f) contribute to the development of a strong and globally competitive European rail industry;
- (g) enable, promote and exploit synergies with other Union policies, programmes, initiatives, instruments or funds in order to maximise its impact and added value.

As defined in the SBA, the “Strategic Research and Innovation Agenda” (SRIA) represents the document covering the duration of Horizon Europe that identifies the key priorities and the essential technologies and innovations required to achieve the objectives of the JU. In accordance with SBA Article 86(5), in the case of EU-Rail, its Master Plan shall constitute the SRIA.

The EU-Rail’s Master Plan builds also upon the “Rail Strategic Research and Innovation Agenda”²⁰ of the European Rail Research Advisory Council (ERRAC). ERRAC is a research platform composed of representatives from most of the major European railway research stakeholders: manufacturers, operators, infrastructure managers, the European Commission, EU Member States, academics and users’ groups. Its mission is to deliver a vision of the railway’s future enabled by Research and Innovation activities.

The Master Plan provides guidance for the Europe’s Rail Joint Undertaking’s more specific tasks, namely:

²⁰ https://shift2rail.org/wp-content/uploads/2020/12/RAIL-Strategic-Research-and-Innovation-Agenda-2020-FINAL_dec2020.pdf

- develop in its System Pillar a system view that reflects the needs of the rail manufacturing industry, the rail operating community, Member States and other rail private and public stakeholders, including bodies representing customers, such as passengers and freight and staff, as well as relevant actors outside the traditional rail sector.
The 'system view' shall encompass:
 - the development of the operational concept and system architecture, including the definition of the services, functional blocks, and interfaces which form the basis of rail system operations;
 - the development of associated specifications including interfaces, functional requirement specifications and system requirement specifications to feed into Technical Specifications for Interoperability (TSI) established pursuant to Directive (EU) 2016/797 or standardisation processes to lead to higher levels of digitalisation and automation;
 - ensuring the system is maintained, error-corrected and able to adapt over time and ensure migration considerations from current architectures;
 - ensuring that the necessary interfaces with other modes, as well as with metro and trams or light rail systems, are assessed and demonstrated, in particular for freight and passenger flows;

- facilitate the research and innovation activities necessary to achieve the objectives of EU-Rail, including low TRLs rail-focused research and innovation activities. In that respect, EU-Rail shall:
 - define and organise the research, innovation, demonstration, validation and study activities to be carried out under its authority, while avoiding fragmentation of such activities;
 - exploit standardisation and modularity opportunities, and facilitate the interfaces with other modes and systems;
 - develop demonstration projects;
 - develop close cooperation and ensure coordination with related European, national and international research and innovation activities in the rail sector and beyond as necessary, in particular under Horizon Europe, thereby enabling the Europe's Rail Joint Undertaking to play a major role in rail-related research and innovation while also benefiting from scientific and technological advances reached in other sectors;
 - ensure, through the cooperation referred here above, the translation of research into effective development effort and development of pioneering innovations and ultimately into market focused innovation through demonstration and deployment;
 - perform any tasks necessary to achieve the objectives set out in SBA Articles 4 and 85.

Five areas of priority for EU-Rail have been determined in its Master Plan:

- 1) European rail traffic management and supporting rail's key role in a multimodal transport system
- 2) Digital and automated train operations
- 3) Sustainable and digital assets
- 4) Competitive digital green rail freight
- 5) Smart solutions for low density traffic lines (cost-efficient regional lines)

These priorities will be underpinned by a system view to ensure a harmonised approach to the evolution of the Single European Rail Area. They will be complemented by forward-looking activities, tackling disruptive technologies and thinking, through performing exploratory research and other complementary activities.

THE JU'S APPROACH TO MANAGING THE CHALLENGES OF THE PANDEMIC

JU's general management response: administrative management

As was the case already in 2020, the JU continued also in 2021 to follow the EC approach in response to the Covid-19 pandemic by implementing special measures designed to protect staff. In particular, this was ensured by applying teleworking arrangements, and, when working onsite, by decreasing physical contacts between colleagues and utilising protective measures. In order to facilitate these measures, the JU provided surgical masks and hydro-alcoholic gel and reconfigured the offices to allow occupation by only one person at a time in individual office rooms. However, application of these measures had no impact on proper functioning of the JU and on carrying out its day-to-day tasks, including those requiring interactions with external parties, such as the auditors.

These measures were subject to regular reviews by a dedicated JU working group composed of four staff members which was established already in 2020. This working group has been mandated to monitor the situation and provide to staff information published by different entities (EC, Belgian National Authorities etc.), as well as clarifying mitigation measures during weekly staff meetings or via the dedicated mailbox enabling staff to contact the working group with specific questions or concerns.

Monitoring instruments have been put in place, such as a registration spreadsheet that helped to comply on an ongoing basis with the threshold of maximum overall occupancy at the JU premises. The staff was also advised to utilise the EC Medical Service IT tool to notify in a secure manner if the staff member was tested positive for C-19 enabling better tracing of the contacts with other colleagues in order to quarantine them.

The JU strived to tackle the negative effects of the pandemic on the staff's mental health by introducing already in 2020 a wellbeing programme.

Despite the vast application of remote working, the continuity of operations since the beginning of the pandemic, with disruptions being extremely rare, was ensured by appropriate ICT architecture and concepts that the EU-Rail JU has brought forward and agreed by all other Jus; in particular, EU-Rail lead the IT contract for cloud computing, Testa hosting and related services for all JUs and some European agencies. To facilitate user-friendly teleworking conditions for staff members, a reimbursement scheme was put in place for purchased PC screens and working chairs, in line with Commission rules.

Covid-19 impact on the JU's activity and mitigating measures

- a) Management of the Programme and financial impact: Grant Agreements management and S2R Programme impact

Already in 2020, the JU has conducted a risk management exercise in order to define a series of fast-track amendment procedures framing favourable measures to alleviate the difficulties potentially encountered by EU-Rail Grant Agreement beneficiaries due to the Covid-19 outbreak. The beneficiaries had been allowed to request an extension of the duration of up to 6 months of the initial project durations through the fast-track amendment process.

16 amendments were processed specifically based on Covid-19 requests that often resulted into extensions of grant duration.

The continued C-19 restrictions in 2021 further complicated the possibility of R&I activities requiring field tests, and by the end of 2021 the Programme outputs were delayed of about additional 6 months compared to 2020 estimations. However, the Programme is still expected to reach the TRL6/7 operational demonstrations planned for conclusion during 2023.

In this respect, the work of the S2R Other Members and other beneficiaries, and of the JU staff should be commended for being able to ensure the progress of the research and innovation activities despite such complex conditions, not only by means of paperwork or lab developments but with concrete demonstration activities on the rail network, whenever possible. Description of operational activities in the field is provided in the Executive summary and further detailed in the IPs and CCA achievements included in Section 1.4 of this document.

- b) Management of the Programme and financial impact: Yearly Members Annual Total Project Costs (TPC)/IKOP and IKAA declarations and certifications

In accordance with article 4(3) of the S2R Regulation, “*the members of the S2R Joint Undertaking other than the Union shall report by 31 January each year to the Governing Board of the S2R JU on the value of the contributions referred to in paragraph 2 made in each of the previous financial years*”. In addition, the S2R Other Members should provide the JU with audit certificates on these contributions (TPC/IKOP and IKAA) by 30 April of each year.

Following the Covid-19 outbreak, and the request received from some Members to have their annual audit certificates provided later in the year, the JU accepted to extend the deadline for some of them, in duly justified cases. More than half of the Members submitted the audit certificates by 30 of April, while the remaining ones proceeded with submission between May and October 2021. Consequently, all the Members complied with their obligations and the reported figures are available in Section 1.8 of the present document.

In conclusion, as much as the pandemic has adversely affected the personal and professional life of individual women and men working at the JU, Members and beneficiaries and their organizations as such, at the same time, the S2R Programme has demonstrated resilience and has progressed towards delivering its objectives as reported in the following sections of this report.

1. IMPLEMENTATION OF THE ANNUAL WORK PLAN 2021

1.1. Key objectives 2021 and associated risks

In 2021, the EU-Rail activities were driven by the overarching objective to progress the S2R R&I Programme according to the revised MAAP and detailed in the AWP 2021. Despite the Covid-19 pandemic, which affected the implementation of selected activities, the Programme continued in delivering its operational objectives.

The main operational achievements in 2021 can be summarized as follows:

Delivery of S2R Programme R&I activities

During 2021, through the operational activities, the Programme Office continued the supervision of the implementation of the 105 Projects and operational contracts of the S2R Programme²¹, awarded

²¹ 4 Light house projects (2015) not included.

and signed since 2016, for an estimated R&I total value of EUR 805,1 million. Details are provided in Section 1.7.

The Programme supervision and monitoring was implemented through 46 specific Control Gates (22 project reviews of CFM projects, 24 project reviews of OC projects) and 176 specific issue reviews (110 specific issue reviews of 22 CFM projects, 66 issue reviews of 24 OC projects) in order to continuously assess the submitted technical deliverables with the support of external experts (in the specific field of the deliverables), when needed. The continuous assessment of deliverables has allowed the JU to be efficient in providing timely feedback to the projects for an effective implementation of recommendations and/or requests for changes.

The process of continuous assessment of deliverables consists in the engagement for each output of the project in a swift review, which may need the support of external technical expertise, and in that case, the JU triggers a specific issue review. This process allows EU-Rail to provide an in-depth technical feedback to the project not linked only to the reporting period review (the control gates), but throughout the lifetime of the action, allowing a better fine-tuning of the activities in relation to the objectives. Additionally, work has been performed on the elaboration of some CCA activities, on KPIs and Standards in particular, the management of 6 quarterly IP Steering Committees, and the follow up of the grant implementation (amendments, reporting, etc.).

Despite some projects being closed in 2021, managing the workload related to the operational activities remained challenging for the JU staff, in particular because two Programme Managers and one Programme Assistant left the Operational Unit.

Signature of grants related to the 2021 Call for proposals

In 2021, the JU awarded and signed 2 grants for a total value of EUR 2,34 million, in response to:

- The topic open for “R&I impact and benefits to make rail attractive for stakeholders”;
- The topic open for “Digital Automated Coupler innovation for the European Delivery Programme”.

For more details, related to call for tenders, procurement and contracts concluded and/or launched in 2021 see Sections 1.5 and 2.4.

Cooperation and communication activities

Stakeholder management and external relations have been maintained through a close collaboration with the European Union Agency for Railways (ERA) in different areas, with the European Railway Research Advisory Council (ERRAC), as well as with the different International and European organizations and associations. A continuous and constructive exchange took place with other Union bodies and agencies, such as GSA, FCH JU, SESAR JU, CleanSky JU, EASA and others.

The JU has also enhanced its communication efforts through the participation – mainly through virtual means - in specific activities, workshops and events in order to promote the S2R Programme participation and inform worldwide the achievements of the S2R JU Partnership.

The following sections of this AAR describe how the JU’s objectives have been pursued, the activities performed on the way towards achieving its goals, and the resources used. In Annex C the JU’s performance is measured against the set of agreed KPIs.

Risks

During 2020, the JU carried out an in-depth risk assessment to identify and evaluate operational and non-operational risks for the achievement of its objectives. The corresponding risks associated with the Programme activities and the financial administration of the JU, requiring continuous ED attention (and when relevant, the attention of GB), as well as the corresponding risk mitigating actions have been communicated via the S2R JU AWP 2021. They are summarised in the table below together with an update on mitigation actions performed in 2021. The listed risks take in particular consideration the situation of the S2R Programme, which enters in its final phase; hence, many risks listed in the past were considered no longer relevant in this stage.

As for the average JU’s risk profile pertaining to 2021, as followed from the annual risk assessment performed, and also from the continuous monitoring of risks and opportunities during the year, this was determined by having moderate to high net criticality of the most relevant risks identified. With regard to Covid-19 pandemic, reference is made to the mitigation measures put in place as the risks associated to it materialized also during 2021.

Risk identified for 2021 AWP	Action plan	Follow-up on action plan for 2021
<p>Cross-project collaboration required to achieve the programme objectives may not be achieved due to 'silo-project management' or restrictions related to 'licenses', 'patents', 'IPR Member's sharing policies' or 'accessibility of past OC project results'.</p> <p>Therefore, individual grant agreement implementation may lead to inefficient knowledge exchange across projects and IPs and may also impact the Programme outputs at system level.</p>	<ul style="list-style-type: none"> - ED Programme Board in place (IP coordinators meet). - Decoupling IP structure from AWP topics. - Further fostering the use of a common S2R JU Cooperation Tool and sharing functionalities. - Dedicated cross-IP meetings. - TD leaders ad-hoc meetings. - Focus on the GAP phase on technical part of COLA between OC/CFM. - End of project letter from the S2R JU to project and IP coordinators to ensure project results use within the Programme. - Models and guidance from the S2R JU. - Simplification of legal structure for collaboration. A S2R JU Common Collaboration Agreement (Common COLA, or 'CCOLA') is under preparation. - In order to ensure connection with national activities, the S2R JU will consider signing specific collaboration agreements with other European and international Organizations, Regions and Member States. 	<p>Actions have been implemented on an ongoing basis.</p>

Risk identified for 2021 AWP	Action plan	Follow-up on action plan for 2021
<p>Efficiency of operations is impacted by high staff turnover together with difficulties for S2R JU to attract new people which may result in positions being filled in with delays, shortage of resources especially (during peak moments), and as a consequence leading to difficulties in getting the work done or achieving the JU's objectives (continuity); this may include a negative impact on other employees' motivation.</p>	<ul style="list-style-type: none"> - This risk is intrinsic to the S2R JU Staff establishment plan. Nevertheless, within the budget constraints, a career plan for staff has been prepared and business continuity is ensured. In 2018, the S2R JU GB adopted a revised decision on Learning and Development; implementing policy was adopted in April 2018 by the ED. - Enhancing the planning of activities will allow for better risk management. - Recruitment of short-term resources (interim or trainees) has been extended. 	<p>Actions have been implemented, such as utilising Bluebook Trainees in accordance with the SLA signed with DG EAC.</p>
<p>Impediments during a project (e.g. changes in regulation/ non-achievement of harmonised requirements/unforeseen planning difficulties in resource planning etc.) might lead to the project not being executed in a timely and/or adequate manner preventing S2R solutions to reaching the market. This may in particular include force-majeure events (e.g. COVID) of longer duration which may lead to difficulties in obtaining the necessary authorisation(s) to organise project demonstrations, resulting in non-completion of such activity in the project concerned.</p>	<ul style="list-style-type: none"> - Ensure appropriate implementation/exploitation plans in GA and at TD/IP level + national migration strategies + investigate possible instrument to support deployment at EU level and implement JU strategy/support + regular follow-up of S2R standardisation roadmaps + coordination with RASCOP, and also directly with ERA, CEN/CENELEC/ETSI + regular follow-up at IPSteCo/SIWG + regular updated with EURID WG + follow-up of regulatory environment. - Change management approach (EDPB). - Continuous risk management and risk response (e.g. regular Covid risk assessment at project level). 	<p>Actions have been implemented on an ongoing basis. Risks at project and IP levels specifically related to the Covid-19 pandemic continued to be closely monitored and their impact on deliverables followed-up.</p>
<p>Coupling Reporting Period with the technical assessment of the project progress of the work and associated deliverables leads to inefficient and ineffective implementation of the action.</p>	<ul style="list-style-type: none"> - Continuous assessment of deliverables decoupled from the Periodic Technical Reporting. - Sufficiently wide and qualified expertise from pool of experts. 	<p>Actions have been implemented on an ongoing basis.</p>

In Q4 2021, the JU performed a new risk assessment exercise with the aim of updating the elements related to risks and opportunities already included in its risk register, as well as identifying potential new ones. Within this exercise, the specificities of the transition period from S2R JU to EU-Rail were also duly taken into account, similarly to other topical internal and external factors and developments having influence on JU's business. The relevant risks following from this assessment exercise, that is those with the highest net criticality, are presented in the EU-Rail Work Programme 2022-2024 and the follow-up outcomes for these risks will be presented in the 2022 AAR.

1.2. R&I activities: the S2R Programme

The S2R MAAP translated the S2R Master Plan into detailed, result-oriented R&I activities to be performed with the objective of delivering the S2R vision as from 2016 onwards.

Addressing through R&I the challenges as they were detailed in the MAAP Executive View opened three opportunities for the railway:

- To become the backbone of current and future mobility concepts (e.g. mobility as a service- MaaS) and on-demand future logistics, through integrations with other modes in view of reaching a climate neutral European economy by 2050;
- To identify and establish new market segments for exploitation;
- To enhance the overall competitiveness of the industry, both in Europe and globally.

This is what the S2R Regulation tasked the JU to do when requesting it to manage all rail-focused research and innovation actions co-funded by the Union. Developing the Innovation Capabilities required a coordinated effort among different rail and non-rail stakeholders to drive innovation at all levels in Europe. The S2R Programme was designed to make a decisive contribution to delivering the essential knowledge and innovation that will provide the building blocks to develop the Innovation Capabilities.

The work conducted within the S2R Programme was structured around five asset-specific Innovation Programmes (IPs), covering the different structural (technical) and functional (process) sub-systems of the rail system. These five IPs are supported by work in five cross-cutting areas (CCA) covering themes that are of relevance to each of the projects and which address the interactions between the IPs and the different subsystems:

- IP1: Cost-efficient and Reliable Trains, including high-capacity trains and high-speed trains
- IP2: Advanced Traffic Management & Control Systems
- IP3: Cost-efficient, Sustainable and Reliable High-Capacity Infrastructure
- IP4: IT Solutions for Attractive Railway Services
- IP5: Technologies for Sustainable & Attractive European Freight.

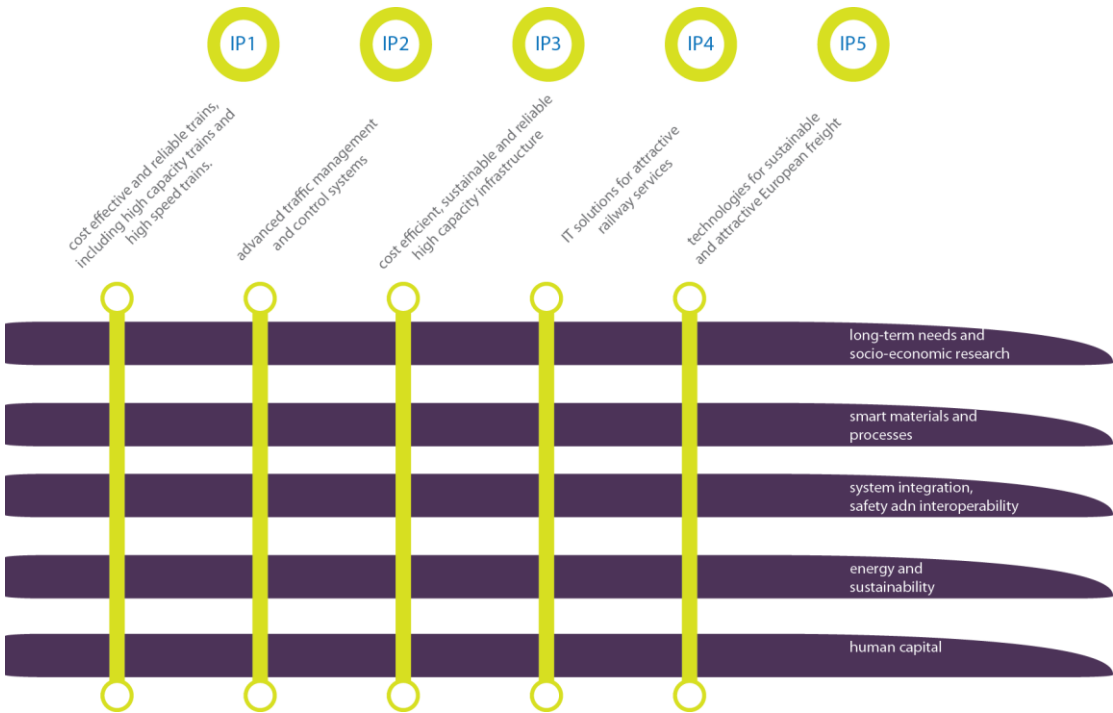

S2R introduced additional IPx activities, R&I designed to look beyond currently planned technology applications (of the Technology Demonstrators) and how to integrate the S2R TDs with new operational concepts. IPx activities help to realise the global optimal approach for this System of

Systems which is railway mobility, by starting to build a railway Functional System Architecture and a Conceptual Data Model (CDM).

In addition, in 2020, the JU set up the European DAC Delivery Programme, to bridge the gap towards future industrialization and deployment of a European DAC solution, building upon the work delivered in IP5 on DAC (see the following sections).

With a holistic approach, the S2R Programme ensured that interactions between the various IPs were adequately considered and managed, as technological developments in one part of the system could lead to changes in performance, or even create barriers, in other parts. In addition, cross cutting activities included research on long-term economic and societal trends such as customer needs and human capital and skills, which must be taken into account by the different IPs.

Different types of activities contribute to the Programme development, including:

- studies, fundamental and “blue-sky” research (TRL 0 – 2),
- scientific/applied research and laboratory demonstrations (TRL 3 – 6)
- operational demonstrations and innovation activities (TRL 6-7)
- other supporting activities.

In addition to these activities that were co-funded by the JU and conducted within the scope of the S2R Programme, the former S2R Other Members were required to conduct Additional Activities with a view to leveraging the effect of the overall R&I. These Additional Activities were not eligible for financial support from the JU but had to contribute directly to the broader objectives set out in the S2R Master Plan.

Since 2020, the management of the Programme benefited also from the regular activities of the ED Programme Board. The ED Programme Board was established as a formal advisory support to the ED and has the role of:

- monitoring the progress of the Programme,
- identifying risks and opportunities and related mitigating actions,
- providing strategic guidance and making recommendations with regard to the management Programme,
- advising the Executive Director in solving issues escalated to his attention in accordance with the S2R Regulation on Programme implementation and propose a way forward,
- advising the Executive Director on the need to complement the Programme with specific expertise to be contracted,
- assisting and advising the Executive Director in any other matter of relevance.

Through its monthly advisory meetings with the Executive Director, the Programme Board has actively supported reflections on and integration of new concepts, ideas, solutions that impacted the Programme. Several change requests have been processes, ensuring among other sectorial coherence of initiatives, notably with the integration of relevant concepts from OCORA or RCA into the S2R R&I activities (projects) that will deliver concrete demonstrations.

The ED Programme Board proved to provide clear benefits to the overall Programme management, anticipating risks and opportunities, ensure higher integration and synergies, addressing issues to avoid negative impact on the expected deliverables.

The progress of the Programme was shared with a wide range of stakeholders during the S2R Innovation Days in December 2021. More than 700 participants had the opportunity to hear about rail's crucial role in the mobility and transport recovery effort, as well as the developments with regard to Shift2Rail's successor.

1.3. Call for proposals and grant information

Considering the annual budget availabilities and the R&I activities planned in the S2R MAAP, the S2R Programme is implemented through combined and interdependent multi-annual Projects. This structured interdependence of the S2R Projects reflects the Technological Demonstrators (TD) and Work Areas (WA) approach set within the Programme and each IP and CCA.

On 15 April 2021 the JU launched its call (H2020-S2RJU-2021) following the adoption of the JU's Amended Annual Work Plan 2021²². This call for proposal covered one S2R IP and CCA in accordance with the AWP 2021. It was open to all eligible entities (both S2R JU Members and Non-Members) in accordance with the Rules of Procedures of H2020.

The respective Decision of the JU GB approving the results of the call was adopted on 22 June 2021²³.

The following tables summarise the amounts and topics related to the call:

Call	Topic	Estimated S2R JU funding
H2020-S2RJU-2021	S2R-OC-CCA-01- 2021	0.17 M€
	S2R-OC-IP5-01-2021	1.6 M€

Topic Code	Topic Description	Type of action
S2R-OC-CCA-01-2021	R&I impact and benefits to make rail attractive for stakeholders	Research and Innovation Action (RIA)
S2R-OC-IP5-01-2021	"Digital Automated Coupler innovation for the European Delivery Programme"	Coordination and Support Action (CSA)

The total number of proposals received in response to the call for proposals was 5:

Call	Type	Number of proposals received	Number of topics
H2020-S2RJU-2021	OC	5	2

A total of 22 participants were involved in the 5 eligible proposals submitted to this call, reflecting respectively on both topics open to them. Following the evaluation, 12 participants (54.5%) are involved in the 2 proposals considered for funding.

²² [Decision N°1/2021 of the Governing Board of the S2R JU of 23 March 2021 on the Annual Work Plan and budget for 2021](#)

²³ [Decision N°3/2021 of the Governing Board of the S2R JU of 22 June 2021 approving the ranked lists of actions selected for funding, reserve list and the list of rejected proposals under the Shift2Rail JU call for proposals H2020-S2RJU-2021](#)

The total S2R JU contribution requested by all the submitted proposals amounted to EUR 3.71 million compared to EUR 1.77 million available for funding:

Call	Type	Requested S2R JU funding	Estimated S2R JU funding available
H2020-S2RJU-2021	OC	3.71 M€	1.77 M€

Following the GB Decision N°3/2021 of 22 June 2021, grants were proposed to be awarded resulting in the amounts provided below:

Call	Type	Total Project Cost	S2R Funding	IKOP	Other contributions to R&I
H2020-S2RJU-2021	OC	2,34 M€	1.77 M€	N/A	N/A

The value of activities resulting from this call to be performed in the coming period in respect to the awarded and signed grants corresponds to EUR 2,34 million that will be funded by the S2R JU up to EUR 1,77 million.

Following the projects selected for funding by the S2R Governing Board resulting from the call 2021 and the four calls from preceding years (2016-2020), the overall value of S2R Other Members ongoing projects is EUR 622.9 million which are expected to be co-funded by the S2R JU up to EUR 272.0 million.

The overall OC amount of ongoing projects awarded in the 2016-2021 calls is EUR 105.9 million.

Open call topics for S2R JU Non-Members: awarded and signed projects

Topic	Acronym	Title	Project value € M	Grant € M	Start date	End date
S2R-OC-IP5-01-2021	DACCELERATE	Accelerated DAC transformation to full digital rail freight operations in Europe	2,17	1,6	01/06/2021	31/12/2022
S2R-OC-CCA-01-2021	BENRAIL	Benefits at rail, top-down holistic approach of impact and benefits to make rail attractive for stakeholders	0,17	0,17	01/10/2021	30/06/2022
TOTAL			2,34	1,77		

1.3.1. Progress against KPIs / Statistics (Annex C)

The Key performance Indicator results for the year 2021 are presented in Annex C. The JU has taken into its scoreboard all Horizon 2020 indicators, which have been established for the entire Research family by the Commission, to the extent they can be applied to the JU in view of providing meaningful results.

Comments to some indicators are provided in the table in the Annex or in the related section of the report, to which the indicators refer. In addition, the S2R JU is presenting more detailed results of its performance monitoring in specific areas, e.g. key figures provided in the section dealing with the call for proposals and the following evaluation process.

Within the context of the CCA activities, during 2021 the JU continued the work to maintain the 'S2R 2030 Impact Forecast Model' ensuring the next Release, resulting from the update of the data input from the different projects and TDs. The latest version shown in Annex C Table IV of the present report provides the figures (Release 4). The KPI tool is fully available to the public on the EU-Rail website (<https://kpi.shift2rail.org/Dashboards/Dashboard/41>)

1.3.2. Evaluation: procedures and global evaluation outcome, redress, statistics

The part of the evaluation process covering verification against the respective requirements/criteria related to the call took place from 19 to 20 May 2021. Due to the specific conditions related to the COVID-19 pandemic, the evaluation procedure was completely performed remotely, making use of digital web-conferencing tools. However, this represented no issue to the proper performance of the evaluation process.

The evaluation of proposals was conducted with the assistance of 3 independent technical experts. An additional expert as recorder was also contracted. Evaluations were conducted in a single panel, with the Commission/DG MOVE representatives and the European Union Agency for Railways representatives having been invited to be present at the panel's meetings as observers. One independent observer was also appointed in accordance with the procedures laid down in the Guide for proposal submission and evaluation of the H2020 grant manual. The independent observer's role was to observe and offer independent advice on the conduct and fairness of the evaluation sessions, on the application of the evaluation criteria and on ways to improve processes.

In selecting the independent experts, the primary objective was to ensure a high level of skills, experience, and knowledge in the areas of the call (including project management, innovation, exploitation, dissemination and communication). Under these conditions, special attention was given to achieve an appropriate balance composition of the panel in terms of various skills, experience, and knowledge, geographical diversity and gender. The composition was the following:

- Gender balance: 3 men (75%), 1 woman (25%);
- Regional balance: representatives from 4 different Member States and Associated Countries.

Similarly to the verification phase conducted in May 2021, due to the pandemic, the consensus meetings of the experts were organised remotely during the period 3 - 4 June 2021. A briefing was held on 3 June 2021, in which the S2R representative provided relevant information related to the consensus phase to the independent experts, such as the specificities of the S2R JU calls for proposals, the confidentiality requirements, or the experts' obligations regarding potential conflicts of interests. Consensus meetings were moderated by staff from the S2R JU and attended as well as by the representatives of European Commission and European Agency for Railways as additional observers.

The total number of proposals evaluated was five, four of them (80%) passed all thresholds set out in the call. Two proposals were retained for funding representing a success rate of 40%. The number of participants in the evaluated proposals was 22 represented by 3 females, 18 males and 1 participant not providing gender information. The number of participants in retained proposals was 12 with

a success rate of 54,55%. With regard to gender composition of applicants' persons in charge for these retained proposals, 2 were female and 10 were male.

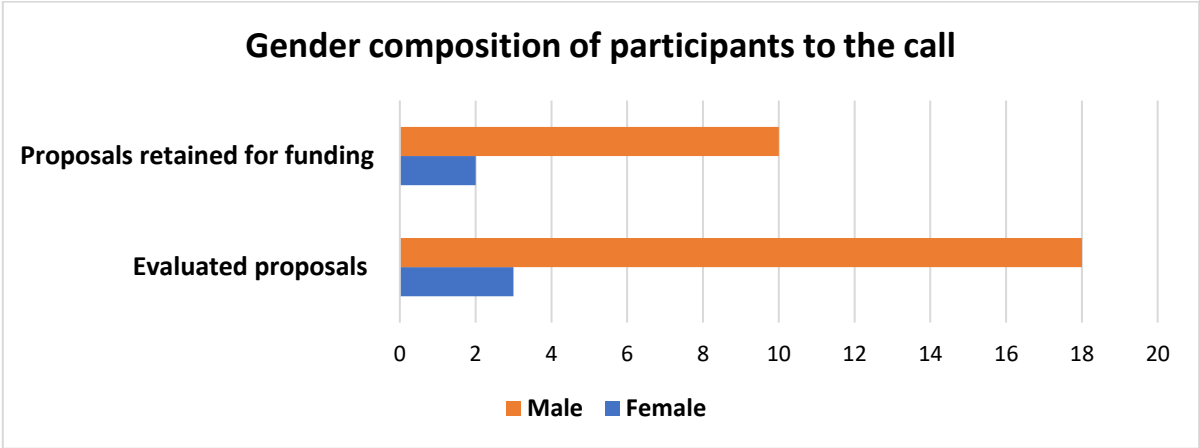

There were 3 SMEs participating in the call with a success rate of 33,33%, one of them having their proposal retained for funding. Participations of SMEs represented 13,64% within the overall proposals evaluated and 8,33% within the proposals retained for funding. The successful SME represents 9% of the entities selected in the respective project (DACCELERATE) and 10% in terms of its share in the total EU contribution to that project.

From a geographical perspective, there were participants to the call coming from 11 countries, there were participants from 9 EU Member States, from 1 Associated Country and 1 participant was from the United Kingdom. After the evaluation, taking into account only the 12 participations in proposals retained for funding, all of those were from EU Member States (see also ANNEX C, Table II).

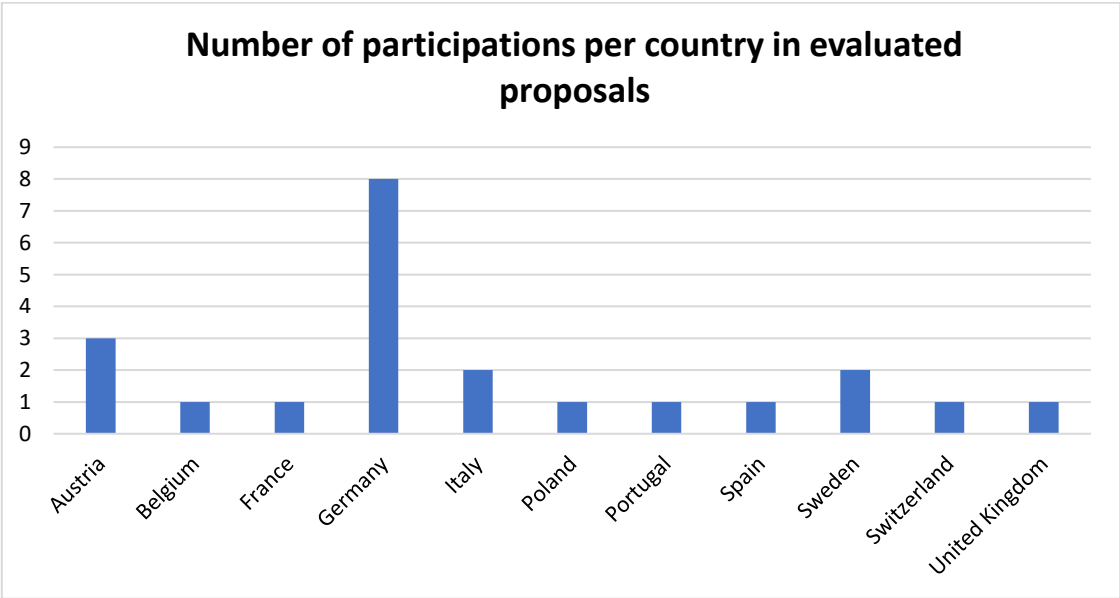

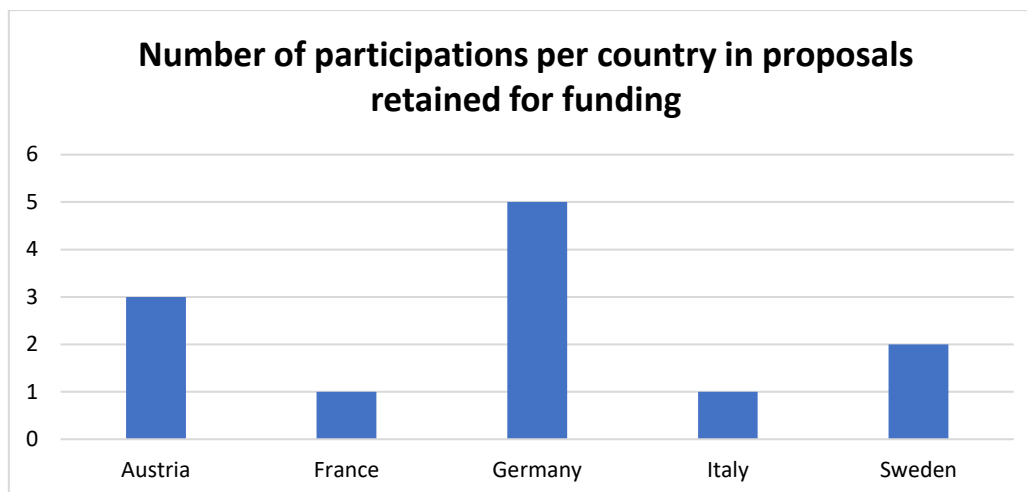

1.3.3. Activities carried out in Grant Agreements

As at 31 December 2021, taking into consideration activities reaching their completion and recently awarded projects, 61 projects were ongoing (29 CFM and 32 OC): 47 projects were distributed among the five Innovation Programmes, 5 projects among the Cross Cutting Activities and 9 projects were part of the IPx. However, it should be noted that even after the project period ends and the final reporting period starts, there is still work that the JU needs to carry out with regard to assessing the final project outputs and to agreeing on the payment of the balance. The detailed overview is as follows:

IP1: Cost-efficient and Reliable Trains, including high-capacity trains and high-speed trains

Project Title	Call Reference	Period	Project Value (signed GA)
CONNECTA-2	S2R-CFM-IP1-02-2018	01/10/2018 - 31/07/2021	€ 9 687 622
PINTA-2	S2R-CFM-IP1-01-2018	01/09/2018 - 28/02/2021	€ 28 534 184
SAFE4RAIL-2	S2R-OC-IP1-01-2018	01/10/2018 - 31/07/2021	€ 3 991 632
PIVOT2	S2R-CFM-IP1-01-2019	01/10/2019 - 31/03/2023	€ 40 155 405
CARBODIN	S2R-OC-IP1-01-2019	01/12/2019 - 28/02/2022	€ 3 334 367
NEXTGEAR	S2R-OC-IP1-02-2019	01/12/2019 - 28/02/2022	€ 2 573 877
PINTA-3	S2R-CFM-IP1-01-2020	01/12/2020- 31/05/2023	€ 19 446 251
CONNECTA-3	S2R-CFM-IP1-02-2020	01/12/2020- 31/07/2023	€ 8 973 663
RECET4Rail	S2R-OC-IP1-01-2020	01/12/2020- 31/05/2023	€ 2 300 036
SAFE4RAIL-3	S2R-OC-IP1-02-2020	01/12/2020- 31/07/2023	€ 6 132 399

Project Title	Call Reference	Period	Project Value (signed GA)
GEARBODIES	S2R-OC-IP1-03-2020	01/12/2020-31/12/2022	€ 2 419 969

IP2: Advanced Traffic Management & Control System

Project Title	Call Reference	Period	Project Value (signed GA)
X2Rail-1	S2R-CFM-IP2-01-2015	01/09/2016 - 30/06/2021	€ 40 878 154
X2Rail-2	S2R-CFM-IP2-01-2017	01/09/2017 - 30/04/2021	€ 28 833 201
X2Rail-3	S2R-CFM-IP2-01-2018	01/12/2018 - 30/11/2021	€ 38 728 459
X2Rail-4	S2R-CFM-IP2-01-2019	01/12/2019 - 28/02/2023	€ 41 109 700
X2Rail-5	S2R-CFM-IP2-01-2020	01/12/2020-31/05/2023	€33 890 375
GATE4RAIL	S2R-OC-IP2-02-2018	01/12/2018 - 28/02/2021	€ 1 019 994
4SECURAIL	S2R-OC-IP2-01-2019	01/12/2019 - 30/11/2021	€ 549 875
OPTIMA	S2R-OC-IP2-02-2019	01/12/2019 - 28/02/2023	€ 2 249 897
PERFORMINGRAIL	S2R-OC-IP2-01-2020	01/12/2020 - 30/06/2023	€ 1 335 359
AB4Rail	S2R-OC-IP2-02-2020	01/01/2021-31/12/2022	€ 349 926

IP3: Cost-efficient, Sustainable and Reliable High-Capacity Infrastructure

Project Title	Call Reference	Period	Project Value (signed GA)
In2Stempo	S2R-CFM-IP3-01-2017	01/09/2017 - 30/09/2022	€ 13 439 981
ASSETS4RAIL	S2R-OC-IP3-01-2018	01/12/2018 - 31/12/2021	€ 5 506 631
FUNDRES	S2R-OC-IP3-01-2019	01/12/2019 - 30/11/2021	€ 749 540
In2Track2	S2R-CFM-IP3-01-2018	01/11/2018 - 28/02/2022	€29 676 014
IN2SMART2	S2R-CFM-IP3-01-2019	01/12/2019 - 30/11/2022	€ 23 091 203
In2Track3	S2R-CFM-IP3-01-2020	12/05/2021-30/12/2023	€ 27 329 170
IN2ZONE	S2R-OC-IP3-01-2020	01/12/2020-31/05/2023	€ 1 349 974
DAYDREAMS	S2R-OC-IP3-02-2020	01/12/2020-31/05/2023	€ 1 709 875

Project Title	Call Reference	Period	Project Value (signed GA)
STREAM	S2R-OC-IP3-03-2020	01/12/2020-31/05/2023	€ 2 700 000

IP4: It Solution for Attractive Railways Services

Project Title	Call Reference	Period	Project Value (signed GA)
CO-ACTIVE	S2R-CFM-IP4-01-2015	01/09/2016 - 31/05/2019	€ 7 621 915
CONNECTIVE	SR2-CFM-IP4-01-2017	01/09/2017 - 31/12/2022	€ 7 906 243
COHESIVE	S2R-CFM-IP4-02-2017	01/09/2017 - 31/12/2022	€ 4 039 492
SPRINT	S2R-OC-IP4-01-2018	01/12/2018 - 28/02/2022	€ 1 999 500
SHIFT2MAAS	S2R-OC-IP4-02-2018	01/12/2018 - 30/06/2021	€ 1 492 363
MaaSive	S2R-CFM-IP4-01-2018	01/11/2018 - 31/07/2021	€ 11 692 236
RIDE2RAIL	S2R-OC-IP4-01-2019	01/12/2019 - 30/11/2022	€ 2 999 993
ExtenSive	S2R-CFM-IP4-01-2020	01/12/2020-30/06/2023	€ 11 308 529
IP4MaaS	S2R-OC-IP4-01-2020	01/12/2020-31/05/2023	€ 2 507 081

IP5: Technologies for Sustainable & Attractive European Freight

Project Title	Call Reference	Period	Project Value (signed GA)
ARCC	S2R-CFM-IP5-02-2015	01/09/2016 - 30/04/2021	€ 3 600 360
FR8HUB	S2R-CFM-IP5-01-2017	01/09/2017 - 28/02/2021	€ 9 900 990
FR8RAIL II	S2R-CFM-IP5-01-2018	01/05/2018 - 30/04/2022	€ 12 450 390
LOCATE	S2R-OC-IP5-01-2019	01/11/2019 - 30/04/2022	€ 1 499 072
SMART2	S2R-OC-IP5-02-2019	01/12/2019 - 30/11/2022	€ 1 708 737
FR8RAILIII	S2R-CFM-IP5-01-2019	01/09/2019 - 31/08/2022	€ 13 061 601
FR8RailIV	S2R-CFM-IP5-01-2020	01/07/2020-31/03/2023	€ 17 604 534
DACcelerate	H2020-S2RJU-2021	01/06/2021 - 31/12/2022	€ 2 171 998

IPX:

Project Title	Call Reference	Period	Project Value (signed GA)
FLEX-RAIL	S2R-OC-IPX-01-2018	01/12/2018 - 30/06/2021	€ 1 099 230.00
B4CM	S2R-OC-IPX-03-2018	01/12/2018 - 30/11/2022	€ 124 951
MVDC-ERS	S2R-OC-IPX-03-2018	01/12/2018 - 30/04/2022	€ 125 000
LINX4RAIL	S2R-CFM-IPX-CCA-01-2019	01/12/2019 - 30/11/2022	€ 5 216 494
RAILS	S2R-OC-IPX-01-2019	01/12/2019 - 30/06/2023	€ 299 954
TRANSLATE4RAIL	S2R-OC-IPX-02-2019	01/12/2019 - 30/11/2021	€ 248 094
LINX4RAIL2	S2R-CFM-IPX-CCA-02-2020	01/12/2020- 31/05/2023	€ 3 228 829
TAURO	S2R-CFM-IPX-01-2020	01/12/2020- 31/05/2023	€ 4 559 803
HYPERNEX	S2R-OC-IPX-01-2020	01/12/2020- 28/02/2022	€ 250 000

CCA: Cross Cutting Activities

Project Title	Call Reference	Period	Project Value (signed GA)
IMPACT-2	S2R-CFM-CCA-01-2017	01/09/2017 - 30/08/2022	€ 7 096 428
TRANSIT	S2R-OC-CCA-01-2019	01/12/2019 - 30/11/2022	€ 1 308 718
FINE2	S2R-CFM-CCA-01-2019	01/12/2019 - 30/11/2022	€ 8 179 973
SILVARSTAR	S2R-OC-CCA-01-2020	01/11/2020 31/10/2022	€ 949 999
Ben[at]rail	H2020-S2RJU-2021	01/10/2021 30/06/2022	€ 169 985

By 31 December 2021, 40 projects were closed, among which:

Closed Projects related to Call for member topics for S2R JU Members

TOPIC	ACRONYM	TITLE	PROJECT VALUE	GRANT	START DATE	CLOSURE DATE
H2020-S2RJU-CFM-2015-01-1	ATTRACKTIVE	Advanced Travel Companion and Tracking Services	5,4	2,2	01/09/2016	31/05/2019
H2020-S2RJU-CFM-2015-01-1	FFL4E	Future Freight Loco for Europe	3,5	1,3	01/09/2016	31/07/2019
S2R-CFM-CCA-03-2015	PLASA	Smart Planning and Safety for a safer and	1,1	0,3	01/09/2016	31/08/2018

TOPIC	ACRONYM	TITLE	PROJECT VALUE	GRANT	START DATE	CLOSURE DATE
		more robust European railway sector				
H2020-S2RJU-CFM-2016-01-1	PINTA	IP1 Traction TD1 and Brakes TD5 – Phase 1	28,8	12,6	01/09/2016	31/12/2018
H2020-S2RJU-CFM-2016-01-1	CONNECTA	CONtributing to Shift2Rail's NExt generation of high Capable and safe TCMS and brAKes. Phase 1.	11,5	5.1	01/09/2016	30/09/2018
H2020-S2RJU-CFM-2015-01-1	FINE 1	Future Freight Loco for Europe	3,2	1,3	01/09/2016	31/10/2019
H2020-S2RJU-CFM-2015-01-1	IMPACT-1	Indicator Monitoring for a new railway PARadigm in seamlessly integrated Cross modal Transport chains – Phase 1	0,6	0,3	01/09/2016	30/04/2018
H2020-S2RJU-CFM-2018	PLASA-2	Smart Planning and Virtual Certification	1,8	0,8	01/09/2018	31/12/2020
H2020-S2RJU-CFM-2016-01-1	IN2Track	Research into enhanced tracks, switches and structures	6,5	2,4	01/09/2016	30/04/2019
H2020-S2RJU-CFM-2015-01-1	FR8RAil	Development of Functional Requirements for Sustainable and Attractive European Rail Freight	11	3,3	01/09/2016	31/08/2019
H2020-S2RJU-CFM-2016-01-1	IN2Smart	Intelligent Innovative Smart Maintenance of Assets by integRated Technologies	15,8	7	01/09/2016	31/10/2019
H2020-S2RJU-CFM-2017	PIVOT	Performance improvement for vehicles on track	16,5	7,6	01/10/2017	31/12/2019

Closed Projects related to Open call topics for S2R JU non-Members

TOPIC	ACRONYM	TITLE	PROJECT VALUE	GRANT	START DATE	CLOSURE DATE
S2R-OC-IP2-01-2015	CYRAIL	Cybersecurity in the RAILway sector	1,5	1,5	01/10/2016	30/09/2018
S2R-OC-IP2-03-2015	MISTRAL	Communication Systems for Next-generation Railways	0,5	0,5	01/11/2016	31/10/2018
S2R-OC-IP4-01-2016	GoF4R	Governance of the Interoperability Framework for Rail and Intermodal Mobility	1,8	1,8	01/11/2016	31/10/2018
S2R-OC-IP4-02-2016	ST4RT	Semantic Transformations for Rail Transportation	1,0	1,0	01/11/2016	31/10/2018
S2R-OC-CCA-01-2015	NEAR2050	NEAR2050 - future challenges for the rail sector	0,4	0,4	01/10/2016	30/04/2018

TOPIC	ACRONYM	TITLE	PROJECT VALUE	GRANT	START DATE	CLOSURE DATE
S2R-OC-CCA-03-2015	DESTINATE	Decision supporting tools for implementation of cost-efficient railway noise abatement measures	1,0	1,0	01/11/2016	31/10/2018
S2R-OC-IP5-02-2015	Dynafreight	Innovative technical solutions for improved train DYNAMics and operation of longer FREIGHT Trains	0,9	0,9	01/11/2016	30/06/2018
H2020-S2RJU-OC-2015-01-2	GoSAFE RAIL	GoSAFE RAIL- Global Safety Management Framework for RAIL Operations	1,3	1,3	01/10/2016	30/09/2019
H2020-S2RJU-OC-2015-01-2	INNOWAG	INNOvative monitoring and predictive maintenance solutions on lightweight WAGon	1,4	1,4	01/11/2016	30/06/2019
H2020-S2RJU-OC-2015-01-2	OPEUS	Modelling and strategies for the assessment and OPTimisation of Energy USage aspects of rail innovation	0,7	0,7	01/11/2016	31/10/2019
H2020-S2RJU-OC-2015-01-2	VITE	Virtualisation of the testing environment	0,9	0,9	01/11/2016	31/12/2018
H2020-S2RJU-OC-2016-01-2	SAFE4RAIL	SAFE architecture for Robust distributed Application Integration in roLling stock	6,7	6,7	01/10/2016	31/12/2018
H2020-S2RJU-OC-2017	IN2DREAMS	Intelligent solutions Towards the Development of Railway Energy and Asset Management Systems in Europe	2,1	2,1	01/09/2017	31/10/2019
H2020-S2RJU-OC-2017	Mat4Rail	Designing the railway of the future: Fire resistant composite materials and smart modular design	3,5	3,5	01/10/2017	30/09/2019
H2020-S2RJU-OC-2017	MOMIT	Multi-scale Observation and Monitoring of railway Infrastructure Threats	0,6	0,6	01/09/2017	31/10/2019
H2020-S2RJU-OC-2017	OPTIYARD	Optimised Real-time Yard and Network Management	1,4	1,4	01/10/2017	30/09/2019
H2020-S2RJU-OC-2017	RUN2Rail	Innovative RUNning gear soluTiOns for new dependable, sustainable, intelligent and comfortable RAIL vehicles	2,5	2,5	01/09/2017	30/09/2019
H2020-S2RJU-OC-2017	SMaRTE	Smart Maintenance and the Rail Traveller Experience	0,7	0,7	01/09/2016	31/10/2019
H2020-S2RJU-OC-2017	ASTRail	SATellite-based Signalling and Automation SysTems on Railways along with	1,8	1,8	01/09/2017	31/10/2019

TOPIC	ACRONYM	TITLE	PROJECT VALUE	GRANT	START DATE	CLOSURE DATE
		Formal Method and Moving Block validation				
H2020-S2RJU-OC-2017	ETALON	Energy harvesting for signalling and communication systems	1,7	1,7	01/09/2017	29/02/2020
H2020-S2RJU-OC-2017	FAIR Stations	Future Secure and Accessible Rail Stations	1,2	1,2	01/09/2017	31/12/2019
H2020-S2RJU-OC-2015-01-2	SMART	Smart Automation of Rail Transport	1,0	1,0	01/10/2016	30/09/2019
H2020-S2RJU-OC-2016-01-2	S-CODE	Switch and Crossing Optimal Design and Evaluation	4,4	4,4	01/11/2016	31/10/2019
H2020-S2RJU-OC-2017	My-TRAC	My-TRAC	3,5	3,5	01/09/2017	31/12/2020
H2020-S2RJU-OC-2018	TER4RAIL	Transversal Exploratory Research Activities for Railway	0,5	0,5	01/12/2018	30/11/2020
H2020-S2RJU-OC-2018	M2O	MAke RAil The HOpe for protecting Nature 2 future OPERATION	0,6	0,6	01/12/2018	31/12/2020
H2020-S2RJU-OC-2018	EMULRADIO4RAIL	EMULATION OF RADIO ACCESS TECHNOLOGIES FOR RAILWAY COMMUNICATIONS	0,7	0,7	01/12/2018	31/12/2020
H2020-S2RJU-OC-2018	MOVINGRAIL	MOVing block and Virtual coupling New Generations of RAIL signalling	1,2	1,2	01/12/2018	31/12/2020

The practical demonstration of S2R R&I activities is carried out using a combination of single technology demonstrators (TDs), integrated technology demonstrators (ITDs and resulting into the Innovation Capabilities) and system platform demonstrators (SPDs).

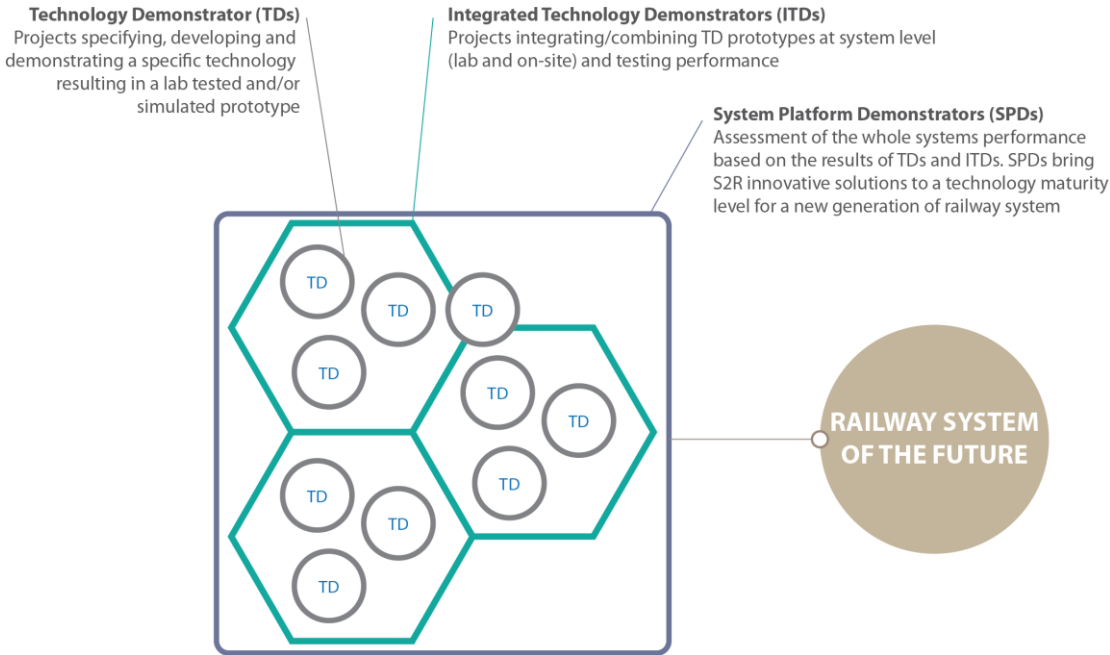

The following sections illustrate the progress achieved in the Technology Demonstrators at the end of 2021. The contributions from the TDs to the delivery of the innovation capabilities, as mentioned in the S2R MAAP (Part A), were elaborated in the S2R MAAP (Part B), adopted by the GB in November 2019.

1.4. Towards delivering the S2R Programme

This section presents for each Innovation Programme the progress of ongoing projects implementing the R&I activities measured through the achievements in the development of Technology Demonstrators. A market correspondence table per TD was published in the MAAP (Part B) in May 2019.

An overview of demonstrators with a Technology Readiness Level reaching at least 6 (technology demonstrated in relevant environment), and of which activities have been performed in 2021, is displayed below, together with the provisional planning for test end.

IP	Research Area	Specific Technological demonstration of	characteristics				Overall high level focus/objective	
			Market	Testing time - YEAR start	Testing time - YEAR end	Country		TRL
IP1	TD1.1 Traction	New Technology Traction Systems	Metro	2021	2022	ES	6/7	New generation traction converter based on advanced semiconductor technologies : Reduction in weight and size and increase in energy efficiency
			Regional	2021	2022	FR	6/7	
	TD1.4 Running Gear	Optimised Materials	High Speed	2020	2022	ES	6	Composite running gear from for independently rotating wheels
		Bogie Control	Generic	2019	2021	DE	6/7	Innovative wheelset guiding based on proven hydraulic actuators minimizing active control
	High Speed		2019	2021	ES	6	Active suspension to improve passenger comfort and vibration reductions	
	TD1.5 Brakes	SIL 3/4 electronic solutions for Brake Control	Urban/Regional	2021	2022	ES	7	Train braking system, based on new architectural HSIL concept, including the replacement of conventional train lines(tbc) and connecting braking safety functions up to SIL4.
		Innovative Friction Pair Solutions		2021	2022	ES	7	High power and eco-friendly friction pairing solution to be tested in a relevant environment
		Adhesion Management		2021	2022	ES	7	Function of a new adhesion management concept/ function within an relevant environment on a test train (operational mode)
		Electro Mechanic Brake		Generic	2021	2021	HU	6
	TD1.6 Door and Intelligent Access system	PRM access and communicating door	Regional	2021	2023	FR, ES	6/7	New door functionalities like platform detection, passenger detection, passenger protection during boarding aid deployment and retract...: - tests of laser-based solution in operation - data collect on a train in operation with the proposed camera - with the recordings, tests of the algorithms based on IA and/or image treatment
		Light and high comfort door	Regional	2021	2023	FR	6	Opening and closing mechanism and the leaves new innovative design: - one door will be based on metallic solutions - another door will be based on composite solutions
TD1.8 HVAC	HVAC-Technology with natural gases	Regional	2020	2022	DE	7	HVAC Laboratory test and field test in real operation, Reduction of climatic impact, Reduction of energy consumption.	

IP	Research Area	Specific Technological demonstration of	characteristics					Overall high level focus/objective
			Market	Testing time - YEAR start	Testing time - YEAR end	Country	TRL	
IP2	TD2.1 Advanced Communication System	markets applications	Mainline/High Speed	2021	2023	FR/DE tbc	6/7	The demonstrators will be used to validate aspects and capabilities defined in the ACS specification documents (incl. support VoIP communication) and assess them in the context of related FRMCS specifications.
		markets applications	Urban/Suburban	2021	2023	UK	6/7	
		markets applications	Regional/Freight	2021	2023	IT	6/7	
	TD2.2 Automatic Train Operation	feasibility of GoA2 solution	Urban/High Speed/Regional	2019	2021	UK, CH	6/7	For GoA2, to check the behaviour of the system (ATO on board and ATO trackside) in a real pilot line.
	TD2.3 Moving Block	Higher Capacity	Urban/Suburban	2021	2023	UK	6/7	Moving Block Demonstration for Urban / Suburban, High Speed and Low traffic railway, aiming to show capacity increase on existing infrastructure, compared with traditional signalling, in lab environment
		Higher Capacity	High Speed Railways	2021	2023	DE, FR	6/7	
		Lower Cost	Low Traffic Railway	2021	2023	SE, IT	6/7	
	TD2.4 Safe Train Positioning	functional block integrated into an ERTMS based solution	Regional/Freight	2021	2022	IT	6	Under review for successful Fail Safe Train positioning demonstration innovative solution integrated with an ERTMS based system
		Fail-Safe Train Positioning Module	Low density traffic lines	2021	2022	Spain	4/6	
		standalone train positioning demo	All	2021	2022	DE, ES, FR	4/6	
	TD2.6 Zero on-site testing	Simulation and testing environment able to support automated laboratory testing	Mainline/Regional/Freight	2021	2023	N/A	6	Corridor 1 of ETCS System could be used for verification of the testing activities with distributed test environments connected to each other from different trackside and on-board suppliers + Human Factors testing
	TD2.9 Traffic management system	Connected Driver Advisory System	Generic	2021	2022	IT	6	Prototype that implements the computation of speed profile and driving modalities to feed a Connected Driver Advisory System (C-DAS)
		Integration of field status information		2021	2021	DE	6	Modules for integrating field status information + forecast from trains, asset and train control into one single, consistent data source; (re-)planning of maintenance activities...
		TMS Business Applications		2021	2021	ES	6	TMS Business Applications focused on the mitigation of the impact that traffic disturbances and unexpected infrastructure restrictions
		Conflict Detection and Resolution		2020	2022	DE	6	Business service applications for the detection of future conflicts, the presentation of the results to the operator and conflict resolution measures and integration into workflow.
		Application Modules		2020	2022	DE	6	Interaction between the TMS providing indication of asset failure on the Integration Layer + selected features of Operator workstation with 3rd party application HMI
	TD2.10 Smart radio-connected all-in-all wayside objects	Verification of Wireless Low Power Object Controller	Generic	2021	2022	ES	6	Autonomous (energy power) object controller prototype to interface with ERTMS balises, signals and track circuits on areas far from stations.
		Track vacancy detection SWOC		2021	2022	DE	6	Track Vacancy Detection (axle counters) with optional signal management and with safe and secured communication over wireless networks.
		Verification of Multiple Networks Scalable SWOC		2021	2022	IT	6	A prototype of wayside object controller that will be able to communicate using the available heterogeneous wireless public networks (e.g. 2G/3G/4G, satellite, ..)
		Verification of SWOC network for managing WOs demonstrator		2021	2022	N/A	6	SWOC and a Wireless Sensor Network for a safe and secure communication as well as transparent routing for the IXL to the object to be controlled.
		Verification of a LX Smart wayside objects		2021	2022	CZ	6	SWOC connected via radio connection to the IXL or to the level crossing (LX) controller to control wayside objects commonly used at an LX – axle counter, gate signal, warning light, light signal or barrier drive.
Verification of SWOC for points machines		2021		2022	ES, DE	6	Controlling of point machines with wireless communication, advanced diagnostic features, optimized distribution, low power consumption + autonomous power supply and storage	
Verification of adaptable Wireless sensor Network for way side objects		2021		2022	FR	6	New generation of low-power and resource-constrained wireless sensor networks (WSN) for adaptive data collection and forwarding for railway environment	

IP	Research Area	Specific Technological demonstration of	characteristics				Overall high level focus/objective	
			Market	Testing time - YEAR start	Testing time - YEAR end	Country		TRL
IP3	TD3.1 Enhanced Switch & Crossing System Demonstrator	RAMS optimised S&C	Generic	2019	2023	AT	7	Monitoring programme for S&C including: Geometry and overrunning, casting, novel rail grade, resilient pads, rail fastening system, base plates, switch roller system, etc.
		Cast manganese frog with welded bainitic component		2020	2023	FR	7	Experimental evaluation of fatigue of cast manganese-crossing for welding technology to join bainitic with pearlite steel components.
	TD3.2 Next Generation Switch & Crossing System Demonstrator	Next Generation S&C System	Generic	2021	2023	UK	5/6	Test next generation design, control, materials and manufacturing to provide a step change in asset performance as a whole (sub)system
		Low N&V Tramway Crossing	Urban/Suburban	2021	2023	AT	6	Test overall performance of a girder rail swing nose crossing in service for the reduction of N&V
		Autonomous inspection of S&C using drone technology	Generic	2021	2023	UK	6	Use of drones to undertake basic visual inspection and potentially supervisor inspections of S&Cs, specifically in areas nonaccessible or visible by other means
		Autonomous repair of S&C using additive manufacturing techniques	Generic	2021	2023	UK	6	Discrete Defect repair (DDR) unit being applied to the automated restoration of worn/ damaged crossings.
		Materials and Components	Generic	2019	2023	UK, SE, FR	4/7	Next generation S&C materials and components tests (i.e. adjustable fastening systems)
		Asphalt Track	Generic	2021	2023	UK	6/7	A site trial for demonstration to assess future assessment of asphalt performance.
	TD3.3 Optimised Track System	Transition zone	Generic	2019	2023	SE	5/6	Tests on improvement of the transition between open track and bridges, open track and S&C, ballasted track and slab track
		New slab track		2019	2023	SE	7	Test of a Modular Slab track solution reducing maintenance costs
		Innovative use of materials		2019	2023	AT	5/6	Test of innovative use of materials and advanced manufacturing techniques
		Laser clad coating on rails		2020	2023	AT	5/6	Test of laser clad coatings on rails nearby and on rail joints; laser hardening and laser cladding of worn rail zones
	TD3.4 Next Generation Track System	Rail Defect Repair	Generic	2020	2023	UK	7	Thermocouple instrumented trials on process for different rail steel grades
		Contactless EMAT ultrasonic defect detection		2020	2023	FR	6	Contactless ultrasonic method to identify rail level defects using the EMAT method
	TD3.5 Proactive Bridge and Tunnel Assessment, Repair and Upgrade Demonstrator	Tunnel improvements	Generic	2020	2023	FR, UK	7	Reduce track and tunnel closure by offsite manufacturing and increase quality
				2020	2023	AT	7	Predict calcite clogging over time
		Bridge improvements	Urban/Suburban	2020	2023	DE	6	Efficient monitoring of noise emission and installation of passive noise dampers.
			Generic	2020	2023	UK	7	Extend bridge service life by lowering fatigue
	High Speed	2021	2023	SE	7	Increase bearing capacity and remaining fatigue life of concrete bridges and increasing safety.		
		2020	2023	SE	7	Make high speed traffic possible on existing bridges with proven dynamic properties		
Integrated Technological Demonstrators Asset Management (TD3.6, TD3.7, TD3.8)	Strategic long-term	Generic	2021	2022	PT, UK	6	Test of a strategic decision support tool based on the tactical planning tool	
	Tactical and Operational short term		2021	2022	UK, SE DE NL, ES, FR	6/7	Maintenance process and strategies through knowledge extracted from information coming from available data and monitoring systems	
	Metro/ Tram Asset Management	Urban/Suburban	2021	2022	IT	7	Demonstrator focusing on minimising maintenance costs, optimising the use of resources while maximising network	

IP	Research Area	Specific Technological demonstration of	characteristics					Overall high level focus/objective
			Market	Testing time - YEAR st	Testing time - YEAR en	Country	TRL	
IP4	Integrated TDs of all IP4 ecosystem	Integrated multimodal ecosystem	Multimodal (rail, bus, metro,...)	2020	2021	PT (Lisbon), ES (Malaga), Central East Corridor	5/6	Demonstration of functional ecosystem, including integrated functionalities (operator Portal, CMMP, Journey Planning, Offer Building, Booking and Ticketing, Access to Ansillary Services, Trip Tracking, Location Based Experiences) within the different scenarios. Through the application show how to plan (booking,shopping, tracking, navigation, notification...) and perform the trip. Different corridors (Lisbon, Malaga and central east) will be presented with a specific use cases for each one covering business or family travel. Integration with a third-party application.
IP	Research Area	Specific Technological demonstration of	characteristics					Overall high level focus/objective
IP	Research Area	Specific Technological demonstration of	Market	Testing time - YEAR st	Testing time - YEAR en	Country	TRL	Overall high level focus/objective
IP5	TD5.1 Fleet Digitalization and Automation	Automatic coupling	Freight	2020	2022	SE	6/7	Telematics and electrification, digital automatic coupling of TD5.1 will be tested. Test in extreme winter conditions. These testing activities will contribute to the compilation of enough evidence so final EU DAC Product specification can be standardised and safety/interoperability requiments updated in the TSI
		Condition based maintenance		2020	2022	DE	6/7	End-to-end solution for predictive maintenance, including processes, data handling, analytics and dashboards, for locomotives and wagons.
		ATO-application for industrial Freight trains		2020	2021	CH	6/7	Freight ATO (GoA2) use cases on ETCS Level 2 track in the open network, using ATO modules of IP2.
	TD5.2 Digital Transport Management	Improved terminals		2021	2023	SE	6	A gate equipped with intelligence as part of a connected decision platform optimizing the work process in a terminal. Sata exchange platform to ensure efficiency and security (of data handling) in the transport chain. Equipment prototypes with HMI interface validated in live demonstration for a selected large and complex terminal.
	TD5.3 Smart Freight Wagon	Telematics		2021	2022	SE	7	Demonstration activities of the intelligent wagon based on telematics and electrification
TD5.4 New Freight Propulsion Concepts	Hybrid / advanced Propulsion	2021	2022	DE, SE	6/7	Demonstration of distributed power (3 Locos) technology developed using LTE with a 700 m heavy coal freight train with loco at the end of the train being remote controlled. Second demonstrator 835 m train.		

1.4.1. IP1 Cost-efficient and Reliable Trains, including high-capacity trains and high-speed trains

The picture below gives a visual perception on where the TDs will introduce improvements.

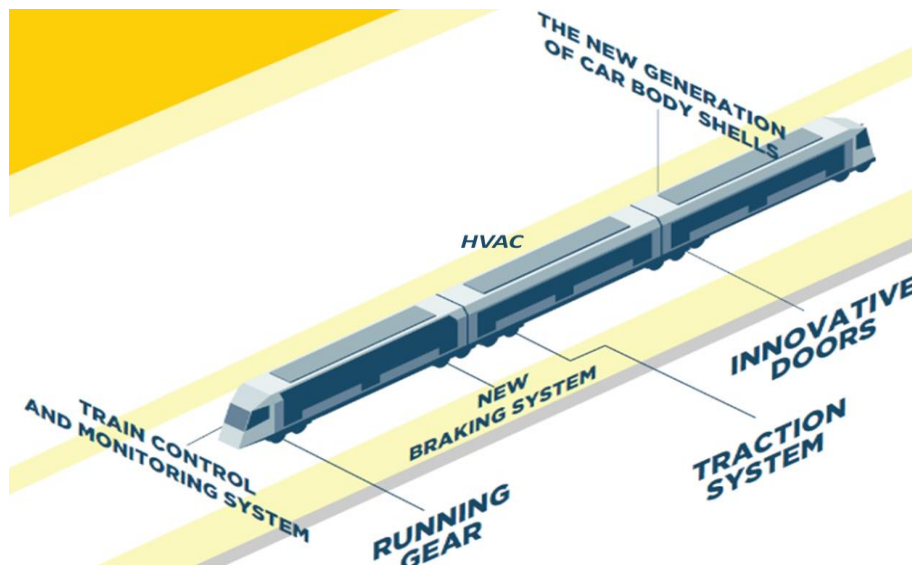

TD 1.1. Traction systems Demonstrator

The TD develops new traction components and subsystems using mainly silicon carbide (SiC) technologies leading to new architectures. The activities aim at producing SiC Technology Demonstrators to be implemented into a tramway, a metro, a sub-urban train, a regional train as well as a traction system based on independently rotating wheels to be demonstrated on a high-speed train.

The SiC application opens up many improvements in Key Performances Indicators (Life Cycle Cost and technical). Besides improved energy efficiency and maintenance costs, it gives additional optimisation possibilities enhancing customer value, such as noise reduction and efficient cooling.

TD progress

Due to the Covid-19 crisis, some deliverables have been delayed by about three months, nevertheless significant progress has been achieved during 2021. Details are given below.

The main objective for 2021 was the preparation and/or the on-train demonstration of prototypes of Traction components at TRL7 levels. The work carried out in 2021 has brought the following main results:

- SiC based Traction components demonstration on a tramway in Germany. The demonstration has been successful, and a public communication is under preparation by Siemens.
- SiC based Traction components demonstration metro, the demonstration started and will last until end of 2022. The actual results are satisfactory.
- For sub-urban demonstrator, lab tests performed within Q2 2021 proved a reliability improvement on the sensors and components.
- Preparation and start (in November) of SiC based Traction system (transformer, traction case, motor and gearbox) on regional trains.

- On HST, the manufacturing of a wheel motor prototype has been done and the motor is tested on a static test bench to prepare a demonstration on train in 2022.

The Traction TD 7 KPIs has been updated: The KPIs progress confirms that most of the targets defined for the end of S2R are achievable and the train manufacturers confirm the viability of the SiC technology for a rapid deployment on commercial markets on Traction systems (the SiC technology has started to be sold on other train components like auxiliary converters or DC/DC interface for hybrid trains). The table below is updated with the latest KPIs results as they are provided by the different FM's contributing to the traction demos. The main benefits of the newly developed traction and brakes components are described in the following chart. The improvement of reliability prediction is mainly due to test feedback from involved electronics and sensors. These electronics and sensors are of new design, and it is proved that predictions were more conservative. The testing and data reflected from the actual behaviour of the sensor is shown by the increased reliability value.

Train/application	Development partner	LCC reduction			Reliability		Train Capacity		Line Capacity	
		Cost	Energy Cost	Maintenance Cost	Reliability	Weight Reduction	Volume Reduction	Noise reduction		
Tramway	Siemens	0% ₃	-10% ₄	-2% ₂	5% ₂	-4% ₂	-5% ₂	Reduction of noise tonality ₂		
Metro	CAF	2% ₄	-7% ₃	-7% ₃	6% ₃	-25% ₄	-25% ₄	-3% ₃		
Sub-urban	BT	0% ₃	-8% ₃	-21% ₂	31% ₂	-10% ₃	-20% ₃	-10% ₃		
Regional	Alstom	2% ₃	-13% ₃	-14% ₂	11% ₂	-17% ₄	-5% ₄	-1% ₂		
High Speed	Talgo	2% ₃	-4% ₃	-5% ₁	12% ₃	-3% ₃	-2% ₃	0% ₃		
Application	Development partner	Cost	Energy Cost	Maintenance Cost	Reliability	Weight Reduction	Volume Reduction	Noise reduction		
HVAC - Regional	DB +	20% ₄	-6% ₃	20% ₁	0% ₁	15% ₃	0% ₃	0% ₁		

The number in % are representing progress compared to the classical Si Traction baselines (tramway, metro, sub-urban, regional trains). The accuracy of quantification is described from 1 to 4, as defined at S2R level by the KPIs consolidation project IMPACT-2. 1 is expert estimation; 4 is demonstrated on a train.

The main point to be underlined is that major energy savings have been demonstrated. This opens the path toward less CO2 trains emissions, both for electric trains and diesel-electric trains, as the SiC technology can be used in all train types. The SiC technology is a good solution to better fight climate change and opens promising possibilities for further R&D action in the next decade, if this technology is used for decarbonised alternative Traction systems like Hydrogen hybrid or Batteries-powered trains.

Links to other national or European entities like Clean Hydrogen JU, Batt4EU or Europsecs (Battery trains and Energy Storage Systems) have been established to underline complementarity between their work.

On traction reliability, the work on power semiconductor lifetime models for the forecasting of device lifetime continued. It will be used in future predictive maintenance algorithms to reduce maintenance costs. Activities to improve the environment requirement specification for power semi-conductors used in railway traction have been strengthened also through a collaborative agreement resulting from the S2R Open Call Recet4Rail. Complementary work on semi-conductor tests is done by two research laboratories in Germany and Sweden and the collaboration of technical experts is efficient.

On virtual validation and certification, the application of virtual design and validation methodologies conclusions are ongoing.

This field of research, in the Digitalisation of railways, will bring very significant commercial projects cost and planning reductions. An estimation of a 30% cost saving on Traction system validation and certification is foreseen within the 2030 horizon, but it still needs further work and discussions (both technical and normative) to practically achieve this result.

The Traction TD is progressing almost according to schedule, Talgo will catch up its delay on wheel-motor in 2022 as forecasted and agreed with the S2R JU.

The availability of power semi-conductors at affordable price is still a topic to be considered carefully and having a credible supplier in Europe would be positive in terms of price reduction. Infineon (Germany) seems to be back in the race with Asian suppliers (1500 V component under test by Siemens) and could help to increase the European industrial competitiveness in this electronic domain.

TD1.1 Traction Systems Demonstrator									
2015	2016	2017	2018	2019	2020	2021	2022	2023	...
Finished: Roll2Rail, PINTA, PINTA2						Ongoing: PINTA3, RECET4Rail			

During 2021, 17 deliverables were planned out of which 10 were released. TD 1.1 has reported having accomplished 60% of the planned work up to the end of 2021, which represents around 65% of the overall TD.

TD 1.2. Train control and monitoring system (TCMS)

The development of a new-generation TCMS (Train Control and Monitoring System) will allow overcoming current bottlenecks caused by physically coupled trains. The new drive-by-data concept for train control, along with wireless information transmission, aims at making new control functions possible; it involves interaction between vehicles and consists, providing high safety and reliability levels with very simple physical architectures.

TD Progress

The TD1.2 builds on the progress made by CONNECTA and Safe4Rail in the first phase, and the work made by CONNECTA-2 and Safe4RAIL-2 projects in the second phase, which have been completed in 2021. In December 2020, the projects CONNECTA-3 and Safe4RAIL-3 were launched with the objective to reach high TRL in the technologies introduced in the next-generation TCMS.

After having reached in the first phase of the projects the definition of general specifications for the next generation TCMS, including a comprehensive list of use cases and the corresponding high level system architecture, the prototypes made in 2020 based on those specifications have been tested and validated throughout 2021. The laboratory test execution has served to overcoming some gaps and specification mistakes made in the CONNECTA project, resulting in a specification update publicly available in the CONNECTA-2 project website. The achieved degree of maturity in prototypes will allow the implementation and deployment of NG-TCMS technologies in the high TRL demonstrators expected in the CONNECTA-3 project (up to TRL 6/7).

The maturity of pillar technologies up to TRL4/5 has been successfully achieved with some important milestones:

- Two different implementations of Functional Distributed Framework (FDF) have been deployed, one based on Autosar Adaptive Platform and another based on Integrity RTOS. Both FDF implementations have been correctly integrated in regional and urban demonstrators respectively and passed a set of Test Cases which have served to validate the fulfilment of requirements defined in Phase 1.
- A common HVAC application deployed by Safe4RAIL-2 has been integrated and validated in both FDF implementations, demonstrating the cross-platform interoperability based on a common Application Profile. Two validation ways have been tested in the project: one based on Functional mock-up Unit provided by the HVAC provider from Safe4Rail-2, which substituted the HVAC unit interacting with the CCU; another one based on remote HIL in which a remote HVAC unit in the HVAC provider’s facilities was integrated in test sequence of the laboratory demonstrator.
- The Simulation Frameworks (SF) allowing software and hardware in the loop simulations have been built and tested. These SFs have been used in 2021 for carrying out the defined Test Cases in order to validate the underlying technologies of Next Generation TCMS.
- Different Drive-by-Data (DbD) compliant Ethernet Train Backbone Node (ETBN), Consist Switches and PCIe cards for End Devices have been integrated by including them in urban and regional demonstrators. However, due to performance problems detected in the validation tests, the equipment delivered by Safe4Rail-2 is currently under re-evaluation and bug-fixing with the expectation to solve the detected issues in Q1 2022.
- The low-level telegrams for the Functional Open Coupling (FOC) for HVAC and Doors applications have been specified, deployed, and tested, using remote connections between CAF, Bombardier and Siemens laboratories to validate them, being a transitional solution to overcome the Covid-19 restrictions.

Moreover, TD1.2 has issued the specification of the standardisation ATO-TCMS interface for GoA2. In 2021, a new step has started including GoA4 functions which will be defined throughout the following years together with the X2Rail-4 project. Moreover, this work is being made following a cooperation with OCORA. This TD has actively participated in the ERA TWG ARCHI, together with LinX4Rail, on the topics related to a One Common Bus.

CONNECTA-2 and Safe4Rail-2 have also performed interoperability tests of the evolved Wireless Train Backbone (WLTB) based on direct communications and the Wireless Consist Network adapted to the Next Generation TCN architecture. This interoperability tests have served to validate two parallel implementations of the Adapted ETBN compliant with the new WLTB specification made in 2019. However, these tests have shown some limitations of the current V2X implementation when using it for wireless inauguration, which is under study in Safe4Rail-3. The main problem detected was an unexpected channel congestion due to the high frequency of exchanged periodic telegrams. The adaptation of physical and link layer of V2X to allow the exchange of the needed traffic profile is foreseen in Safe4Rail-3. The Wireless Inauguration protocol validated between both projects is currently under discussion in the WG43 to be included as a suitable input for a new standard of IEC 61375 series tackling Wireless Train Backbone.

With the finalization in July 2021 of CONNECTA-2 and Safe4Rail-2, the running projects of this TD remain CONNECTA-3 and Safe4RAIL-3, which are currently progressing in complementing the specification and implementations regarding the RFID transceiver information acquisition and WLTB multidomain support.

TD1.2 Train Control and Monitoring System Demonstrator									
2015	2016	2017	2018	2019	2020	2021	2022	2023	...
Finished: Roll2Rail, CONNECTA, SAFE4RAIL, CONNECTA2, SAFE4RAIL2						Ongoing: CONNECTA3, SAFE4RAIL3			

In 2021, 20 deliverables out of 23 planned have been delivered. The overall progress is in line with the plan. TD 1.2 have accomplished around 90% of the planned work up to end of 2021, which represents 75% of the overall TD progress.

The overall progress is in line with the plan established in the Multi Annual Action Plan. TD1.2 has experienced a slight delay due to the Covid-19 pandemic which will potentially be overcome by the extension of the CONNECTA-3 and Safe4Rail-3 projects. The work accomplished throughout 2021 paves the way to achieve successfully the High TRL Demonstrators planned to 2023, when the TRL of these technologies will be scaled up.

TD 1.3 Car body shell

The new generation of car body shells using composite or other lightweight materials will lead to significantly lighter vehicles that carry more passengers within the same axle load constraints, using less energy and reducing impact on rail infrastructure.

TD Progress

The TD1.3 builds on the progress made by the projects Roll2Rail, Mat4Rail and PIVOT, and currently consists of the running projects PIVOT2 and GEARBODIES (started in December 2020).

In 2021, the TD1.3 has been focused on manufacturing engineering including moulding design, assembly jigs and procedures. Main moulds have been produced, for example the lateral moulds as shown in the picture below.



Together with the mouldings, first composites and metal subassemblies have been manufactured. The first section of the lateral and the main pultrusion beam is also shown below.



The results show that the reduction in weight is greater than 20% in all the cases, reaching circa a one-tonne reduction in the full car body of a HST, in accordance with the expectation defined in PIVOT.

Regarding standardisation, the activities of the working group in CEN/TC 256/SC 2/WG 54 are ongoing to establish a new “Process standard for the introduction of new materials” with active contribution of TD1.3.

In parallel, the activities have been started for automatic inspection of car bodies with an eye on maintenance purpose.

TD1.3 Carbody Shell Demonstrator									
2015	2016	2017	2018	2019	2020	2021	2022	2023	...
Finished: Roll2Rail, Mat4Rail, PIVOT				Ongoing: PIVOT2, CARBODIN, GEARBODIES					

During 2021, 12 deliverables were planned and all of them were released. TD 1.3 has reported having accomplished 95% of the planned work up to the end of 2021, which represents 65% of the overall TD (as some delayed deliverables were submitted at the time of this report).

The high TRL demo, a full high-speed intermediate coach, as follows from the demo plan, will be finished in the last part of 2022 and will be tested in Spain before the end of 2023.

TD 1.4 Running gear

TD 1.4 continues to work on innovative developments of new architectural concepts, new actuators in a new lighter wheelset, frame and other components, leading to innovative functionalities and improved efficiency and performance levels.

The TD1.4 builds on the progress made in 2021 by the project PIVOT2, GEARBODIES and NEXTGEAR.

- *Sensor and health monitoring functionality*

The development of the different health monitoring systems for condition-based maintenance has continued. Regarding onboard solutions, an Acceleration Measurement System for Running Gear has been designed and integrated in the train. This phase consists of the previous step before the launching of Proof-of-Concept Campaign during next year. On the other hand, an IoT Platform on the Cloud has been designed with the purpose of taking into Production algorithms and rules for monitoring Health Status of Running Gear Components, as Bearing, Guidance of the Train and Stability and Comfort Acceleration.

With regard to wayside systems, a deep analysis of the results measured with the first prototype has been carried out. Health status models for primary suspension, flats and ovalisations have been developed and tested.

The track inspection system has been tested to determine the presence of corrugation in an operational way. Preliminary results have been obtained and compared to standard measurement methods. Different techniques based on Machine Learning have been compared and implemented.

Finally, hardware solutions have been further developed with the aim to ease the implementation of these systems in real environments.

- *Active Suspension and control technology.*

Multibody simulation integration flexible car body and running gear frame model have been done. This could enable better adjustment of the active suspension systems. Active levelling system design has been completed to start the purchase of components.

- *Noise and Vibration reduction*

These activities rely a lot on testing. During the pandemic, testing opportunities were very limited. However, an initial assessment has been launched to study the effect of novel lightweight materials and active suspensions systems and an optimisation strategy for controlling the structure-borne noise transmission through a transmission path test campaign. A reduction of the rolling noise has been estimated, establishing a target of -2dB. The test campaign has been delayed and that is the reason why no results can be shown yet.

- *Optimised Materials*

The prototype of the composite frame for an independent rotating wheel running gear was produced. The whole frame achieves a weight reduction of 46% for the whole frame. Static test according to EN 13749 has been finished successfully with also a good correlation between model and reality. NDT

method like ultrasonic inspection has shown the potential for maintenance application for monolithic structures. Standard fatigue testing until 10 million cycles has been started.

The composite antenna beam was fatigue-tested by using a simplified load spectrum.

For the light-weight axle, which leads to weight reduction and therefore to decreased maintenance costs, a long-time test started in August 2021. The first empirical values from the freight application are available and the weight reduction expectations up to 26% were confirmed. The transmission of the results of the freight application to the metro application started and concept studies are in progress. The 3D concept design was finished end of October 2021. As the next step, the metro wheelset manufacturing will be planned, and production will get started in 2022.

A presentation of the light-weight axle was shown at a conference in Hungary as well as at the S2R Innovation Days in Brussels in December 2021. Within the collaboration with NEXTGEAR, a carbon fibre composite frame for the proposed novel single-axle running gear has been designed. Following a material characterization of the selected, approved composite material system, a frame specimen has been manufactured. The total weight including metallic inserts was 77 kg. The frame was subjected to testing of its natural frequencies and static performance during 2021. Test results showed good agreement with the models that were used in the design considering both mechanical loads and running performance.

In addition, the conclusions from the studies have been summarised in a deliverable on functional specifications for the wheelset of the future using composite material. Moreover, an aerial bracket for a metro vehicle has been developed for additive manufacturing. A component demonstrator was manufactured, mounted on an existing bogie, and was subject to mechanical testing by Metro Madrid. The weight was reduced by 60% compared to the reference component and the number of parts to assemble was reduced from 17 to 2.

With the aim to reduce LCC for running gear parts, rubber material parts are under investigation. A selection process was performed in a collaboration environment. The final choice was made about the two running-gear components to be prototyped. As the next steps in the process, the formulation of the new elastomer and selection of the rubber can get started, as well as the elastomer-metal interfaces design and the preparation of the testing plan.

- *Virtual certification*

The methods currently used in the railway sector and assessment of current methodology was investigated following the guidelines established by EN 14363:2016. After a benchmark performed in 2020 on existing different approaches around the world, work has been concentrated on methods to build and validate a vehicle model. This revealed the need for automatic tools (specific development) to help the user of simulations software. The influence parameters to validate a dynamic model of a vehicle have been explored. The use of simulations with the aim of limiting over-speed tests or fault modes cases will be the next steps starting in 2022.

- *Universal Cost model 2.0*

The Universal Cost Model from the Roll2Rail Lighthouse project has been further developed. During 2021, a part of the work consisted of updating the technical modules. The OC NextGear has also been working on the improvement of the Track settlement model and developed a new method to calculate damage and costs for railway switches and crossings. NextGear has finished the deliverable 1.1 Infrastructure Damage Module of UCM 2.0. A preliminary UCM tool was developed, which will be used in the validation case studies in PIVOT2.

This year, also an Advisory Group for the UCM2.0 was formed to discuss the development of the UCM 2.0 and its acceptance. There was one advisory group meeting this year, where the change management process of the tool was also discussed to control UCM tool evolution, proposed changes and versioning.

TD1.4 Running Gear Demonstrator									
2015	2016	2017	2018	2019	2020	2021	2022	2023	...
Finished: Roll2Rail, Run2Rail, PIVOT					Ongoing: PIVOT2, NEXTGEAR, GEARBODIES				

During 2021, 18 deliverables were planned out of which 11 have been released. TD 1.4 has reported having accomplished 75% of the planned work up to end of 2021, which is estimated to represent 60% of the overall TD.

The overall status of the high TRL demos in 2021: TD 1.4 could reach several milestones on the way to providing the demonstrators. The new health monitoring systems and condition-based maintenance of the track with a novel sensor system (hardware) were able to produce a prototype that will get tested during the next period. Control algorithms for active curve steering have been developed which significantly reduce wheel and rail damage in curves. A composite frame for an independent rotating wheel running gear with high structural requirements has been manufactured and will be tested in the next steps. A light-weight axle was developed. The axle is already being tested in a freight-wagon application. The test results will help to convert the light-weight axle into a metro application during the next year. Finally, work on a way to validate a virtual certification model has begun and is to be continued during the demonstration activities.

TD 1.5 Brakes

The main objective of Technical Demonstrator 1.5 Brakes is to develop novel braking systems and contribute to the achievement of overall Shift2Rail’s mission of increasing the attractiveness of railway by:

- improving the performance, reliability and punctuality,
- increasing line capacity
- reducing lifecycle costs.

Building on the results achieved by the already completed projects Roll2Rail, CONNECTA, PINTA, PINTA-2 and PIVOT, the focus of TD Brakes in 2021 was on developing innovative solutions in five areas:

1. Ability to implement brake control functions on electronic platform compliant with safety integrity level SIL 3 and 4,
2. Innovative friction pairing solutions to reduce noise and dust emissions,
3. Electro-mechanic braking system to replace conventional pneumatic and hydraulic technology,
4. Methods and tools for virtual validation and certification of braking system,
5. Improved adhesion management systems for traction and braking; improved virtual testing for WSP systems.

TD Progress

High SIL electronics

To ensure the safety of passengers and goods and achieve the required safety integrity level (up to SIL4) for certain braking functions, modern railway vehicles rely on conventional technology, i.e.

pneumatic signals and brake control. The development of an electronic brake control function compliant with high-safety integrity level (SIL3/SIL4) will provide more accurate control and reduction of overall vehicle weight.

After successfully performing the laboratory tests in 2020, last year the task force installed and started testing the new generation of a high SIL braking system on an existing EUSKOTREN train in the field. A newly developed strategy for specific distribution of braking force along the train was implemented to optimize the performance of the braking system in low adhesion conditions. Furthermore, preliminary work on Brake Application Profile such as the definition of use cases and equipment vehicle class was done.

Innovative friction pairings

This research area focuses on the development and design of a new generation of disc and friction material to reduce noise and braking dust and improve braking performance. Furthermore, by reducing the wear of the materials, a longer lifetime is possible, which reduces LCC costs.

Following the concept development carried out in previous years, different friction pairs have been manufactured. The components of the friction pairs (brake disc + brake pads) have been developed to fulfil the requirement to reduce noise and dust emission. Two different technologies are investigated that have the potential to improve brake discs: a specific surface treatment and a dedicated geometry. At the same time, suitable brake pads with different geometries and materials have been manufactured to fit the characteristics of the newly developed discs.

A series of dynamometer tests have been carried out to obtain fundamental information about the following features of the different friction pairs:

- braking performance under different test conditions,
- wear of the brake disc and pad,
- noise emissions level,
- dust emissions level.

Moreover, a commercial reference friction pair has been selected and tested under the same test conditions as the friction pairs prototypes to have a direct comparison of the obtained results, under consideration of the focus points listed above. The next step is the evaluation of the test results that will be published in Deliverable D10.7 Friction Pairing – Prototype implementation and test report in March 2022.

Electro-mechanic braking system

Currently, railway vehicles deploy either pneumatic braking system in form of purely pneumatic systems, electro-pneumatic system or electronically controlled pneumatic braking systems. Technological trends like electrification and the vision of airless train together with the urge to reduce vehicle weight and lifecycles costs drive the development of electro-mechanic solution. Effective transfer of braking signal, better diagnostics and fewer components and, thus, significant reduction of system weight, energy consumption and lifecycle costs are just some of the advantages of electro-mechanic braking systems.

In 2021 a revision of the brake calculation model (see Deliverable D9.2 EM-Brake Brake Calculation for more details) was performed to include additional details of the model inside the software application. In the second quarter of 2021, a kick-off meeting was held to launch the discussion on the interfaces between vehicle and electro-mechanic brake that will serve as a basis for the description of the

functionality on the system level. Deep-dive investigations of wiring and diagnostics, safety and test bench design will follow.

Virtual validation and certification

One of the major cost drivers for the authorization of braking systems currently stems from the necessity to perform comprehensive laboratory and on-train tests as a final validation of the system performance. Building on the work of Roll2Rail and PIVOT, the main objective of this task is to propose improvements to reduce homologation costs and shorten the time necessary for putting rail vehicles in service by using simulation.

In 2021, a simulator implementing the specification elaborated in 2020 was developed for demonstration purposes. Additionally, a CSM-RA has been started to analyse and mitigate potential risks emerging from virtual testing of braking performance. This will be assessed by an independent AsBo and supported by dialogues with NBRail and ERA.

Adhesion management

Unpredictable physical phenomena in wheel-rail contact make exact determination of braking distance very difficult and hinder all efforts in increasing capacity by taking sufficient braking distance reserves into account. The main objective of this task is the development of solutions (and testing methods) capable of better management of adhesion condition variation to significantly reduce braking distance and torsional vibration during traction and increase capacity and punctuality.

Following the successful laboratory trials in 2020 that confirmed the validity of developed concepts, last year the preparation for solution validation (planning of measurement campaigns) was performed. The task force installed and started testing the new generation of adhesion management system on an existing EUSKOTREN train in the field, other field measurements (traction and electro-dynamic brake control, torsional vibration reduction and blending strategies) will follow. Also, the adhesion catalogue was updated (load and magnetic track brake influence) and discussions on adhesion consideration in ATO/ETCS (use cases, norms and standards and determination of wheel/rail adhesion) have taken place.

TD1.5 Brake Systems Demonstrator									
2015	2016	2017	2018	2019	2020	2021	2022	2023	...
Finished: Roll2Rail, CONNECTA, SAFE4RAIL, PINTA, PIVOT, PINTA2						Ongoing: PIVOT2, CONNECTA-3			

During 2021, all 5 planned deliverables were submitted. TD 1.5 has reported having accomplished 100% of the planned work up to end of 2021, which represents 80% of the overall TD. By the mid of 2023, TD 1.5 Brakes is expected to deliver 6 demonstrators of TRL 4-6:

- Full brake system including new generation high SIL brake control equipment (on field demonstrator),
- Innovative friction pairing solution (on field demonstrator),
- Field test of adhesion management solutions,
- Field test with EM brake (one bogie),
- EM brake solution completely hydraulic-free (laboratory validated prototype),
- Laboratory-validated demonstrator for virtual validation and certification.

TD 1.6 Doors and Access Systems Demonstrator

The challenge of the TD is to provide the public with seamless, flexible and safe access to the train, including persons with reduced mobility, in addition to improve comfort features like noise and

thermal insulation. On top of that, this TD is bringing more functionality to the door and access systems toward self-managed and autonomous door for automated train operations till GoA4. Everything must be done with costs and weight constraints.

TD Progress

The TD 1.6 builds upon the progress made by the PIVOT2 and CARBODIN projects.

Door leaves design for acoustic attenuation, thermal insulation and weight reduction

Metallic door leaves: In 2021, the work focused on validation tests and on the detailed design of the door leaves. This new design was developed around the use of the new type of structural profiles for thermal insulation and the innovative filling for acoustic attenuation in the new structure of the door leaves (complex arrangement of rigid and flexible materials inside the door leaves instead of rigid foam). The prototypes are launched and should be delivered for testing and mounting in a single sliding-plug door mock-up in early 2022.



Figure 1 - Bending test of insulated pillars

Composite door leaves: In 2021, PIVOT2 activities mainly focused on the design and building of the manufacturing tool. This tooling, directly purchased by the S2R JU, will be used in early 2022 to mold the one-block composite part for the door leaves with the press-molding process while CARBODIN studied an alternative design based on infusion process. Specific actions have been pursued aiming at the improvement of the acoustic attenuation which has been degraded by the weight decrease.



Figure 2 - View a 1/3 scale composite part for a door leaf

The performance of the 2 doors will be measured and compared in 2022 and they will be mounted on the same static regional train for the second half of 2022.

Accessibility

In 2021, PIVOT2 made detailed studies on the improvement of the door threshold for sliding doors, reducing offsets and removing slopes between the tread of the bridging plate and the vestibule floor. The door sealing is also considered in the study for acoustic attenuation. The solution will be tested in a door mock-up at the end of the first quarter 2022. In the meantime, PIVOT2 will develop and build an improved bridging plate while CARBODIN equipped a bridging plate / ramp with sensors measuring the distance to the platform and performed user accessibility tests of a bridging plate / ramp in September 2022.

Door surveillance and safety

In 2021, PIVOT2 prepared and mounted a laser sensor on the inner faces of door leaves for touchless detection of passengers and obstacles between the door leaves.



Figure 3 - View of laser scanner for touchless obstacle detection

A camera was also implemented on the external face of the vehicle centered above the door. Thanks to a collaboration with Euskotren, the experiment in revenue service started in November 2021 aiming first at validating the touchless passenger and obstacle detection with the laser sensor and, secondly, at collecting videos. These videos will be used to check and improve the algorithms for the functions like platform detection, platform position measurement, virtual pushbutton, contactless obstacle detection, passenger detection on bridging plates or ramps, and surveillance of the door area during train departure.



Figure 4 - View of camera centered above the door

Integrated door and demonstration

PIVOT2 has finished endurance tests of new swinging arm developed for weight reduction and load withstanding. As said above, the mock-ups of a single sliding plug door and a sliding door will be mounted early 2022 for testing. A last mock-up of double sliding plug doors with composite door leaves and with metallic door leaves will also be implemented in 2022 on an SNCF static train.

The experiment of the door functions will continue in 2022 with possibly gradual improvement and activation of the functions.

TD1.6 Doors and Access Systems Demonstrator									
2015	2016	2017	2018	2019	2020	2021	2022	2023	...
			Finished: PIVOT						
					Ongoing: PIVOT2, CARBODIN				

In 2021, 4 deliverables were planned out of which 2 were released due to the rescheduling of tasks between PIVOT2 and CARBODIN. TD 1.6 has reported having accomplished 80% of the planned work up to end of 2021, which is estimated to represent about 50% of the overall TD.

TD 1.7 Train Modularity in Use (TMIU)

The TD develops new modular concepts for train interiors (face and roof) that allow operators to adapt the vehicle layout and atmosphere to the actual usage conditions more quickly and at a lower cost. The objective is to provide the operators with better opportunities of being flexible to the demand and reducing the global cost and the global time to integrate new interiors.

The TD also includes rethinking the driver's cabin to be more compact and evolutive, less costly and more human-centred. It is a prospective design for new driving which impacts the space, the use, and the technologies.

TD Progress in 2020

The TD1.7 builds on the progress made by PIVOT-2.

INTERIORS:

Three pre-concepts have been designed to reinforce the KPIs aimed at reducing by two the global cost:

1. Finalisation of the Pre-concept Phase. Three pre-concepts to simplify fixing/unfixing equipment taking into account the lighting.

In July 2021, the three pre-concepts have been finalised with 3D model and preview («white mock-up») to allow the technical pre-studies.

2. Studies of the physical mock-up scale one. Based on the preconceptions (face and roof), a specific design of the mock-up has been decided and two windows length with a mix of pre-concepts have been developed during the summer and autumn 2021. The product of the mock-up will be performed in 2022.
3. Selection of two concepts to be developed in detail in 3D for the virtual mock-up. First main design choices have been made during the autumn 2021 (shape of the panels, first proposal of fixation systems and integration of the lighting). The final design and the immersive mock-up will be developed in 2022.

Two final concepts will be finalised in 2022 and associated with technical studies and be integrated in the demonstrator's scale 1 and virtual mock-up of the TD 1.7 at InnoTrans 2022.

CABIN:

The topic “driver’s cabin” has progressed with the finalisation of the technical analysis, the first European survey and the start of the design Phase.

1. Technical analysis: technologies / Define the GOA for railways / Define the future role of driver / Overview of European driver’s cabin and equipment / analysis of cost / analysis of weight.
2. European surveys: the European Survey 1 to have an overview of the level of acceptance of the new technologies to drive has been conducted during the spring by means of the Open Call CARBODIN with the support of PIVOT-2. 1700 drivers were asked by a questionnaire online. The Survey 2 (physical test) is ongoing since the autumn 2021 to identify more clearly the opportunities of the technologies and will increase the knowledge for the design Phase of the new cabins.
3. The design phase started in September and was finalised in November with a first main choice of the identities to be developed. The development of the design of three pre-concepts will be done during the winter 2021 and spring 2022.

The year 2021 was a year of development of the concepts and the start of the design of the mock-ups. The main choices were made or will be made for the end of the year 2021. The year 2022 will be dedicated to finalising the development and building the demonstrators.

TD1.7 Train Modularity In Use (TMIU)									
2015	2016	2017	2018	2019	2020	2021	2022	2023	...
Finished: Roll2Rail, Mat4Rail, PIVOT					Ongoing: PIVOT2, CARBODIN				

In 2021, 6 deliverables were planned out of which 3 were released due to the rescheduling of tasks between PIVOT2 and CARBODIN. TD 1.7 has reported having accomplished 90% of the planned work up to 2021, which is estimated to represent about 50% of the overall TD.

Three demonstrators are planned for InnoTrans 2022: one physical mock-up to test new interiors (face and roof), one immersive mock-up (virtual) of 2 complete concepts of Interiors, and one immersive mock-up (virtual) of three prospective concepts of driver’s cabin.

TD 1.8 HVAC

Conventional “Heating, Ventilation Air Conditioning and Cooling” systems (HVAC) within rail vehicles use artificial refrigerants that have a very high impact on global warming (e.g. R134a). In order to limit the climatic impact from HVAC systems, the European Union introduced in 2014 regulation No 517/2014 which aims to reduce the use of artificial refrigerants within the EU according to a fixed time schedule. Hence, there is a strong need to develop HVACs using natural refrigerants such as air or CO₂.

Within TD 1.8 two HVAC demonstrators with CO₂ refrigerants are specified, developed and tested in real operation (TRL7). At the end of the project these HVAC units are ready for application within new trains and for the refurbishment of existing trains.

Further activities are the pre-standardisation of mechanical, electrical and control interfaces of HVAC units, as well as fundamental work on alternative refrigerants.

The activities are carried out within the PIVOT2 and PINTA3 projects.

TD Progress

In 2021, the laboratory tests of both HVAC units were finalised and documented. Subsequently, the measurement parameters for the field test were specified and measurement systems were installed. The field tests have started in August 2021:

- Faiveley HVAC unit mounted on a MIREO regional train from Siemens
- Knorr HVAC unit mounted on a double-deck coach from Bombardier

Both trains are in commercial operation. Continuous measurement values are collected for the new CO₂ HVAC units and the reference units with the artificial refrigerant R134a to compare both units. Up to now the new units are running without failures. The preliminary results of the field tests are documented in deliverable 7.1 “Interim field test report and fundamental work” of PINTA3 Project. The results show that it is possible to achieve the same thermal comfort using an HVAC unit with the natural refrigerant CO₂ and replace artificial refrigerants with a long-term sustainable solution. In terms of energy consumption, the CO₂ unit is lower for heating due to the integrated heat pump and slightly higher for cooling. The reduced energy consumption is especially important for future application in battery and fuel cell trains to increase their operational range.

During 2021, pre-standardisation work for control interfaces in collaboration with the Shift2Rail project CONNECTA-2 (TD 1.2 TCMS) was finalised. The results are documented in the document “Technical Application Profile – HVAC – Subsystem” and in which the HVAC application is based on a TCMS common FDF. Furthermore, the pre-standardisation work for mechanical and electrical interfaces was continued.

Finally, in 2021, the KPI improvements of the new HVAC technology were estimated. CO₂ HVAC units with an integrated heat pump led to a reduced energy consumption, but they are heavier and more expensive than conventional units due to the higher pressure required.

The TD work will be continued in 2022 within PINTA3 in relation to the HVAC tests and provision of the evaluation of final results. The final results are planned for October 2022.

TD1.8 HVAC									
2015	2016	2017	2018	2019	2020	2021	2022	2023	...
						Ongoing: PIVOT2, PINTA3			

In 2021, the only deliverable planned was submitted with one month delay. TD 1.8 reported having accomplished 100% of the planned work up to the end of 2021, which represents approximately 60% of the overall TD.

1.4.2. IP2 Advanced Traffic Management and Control System

The picture below gives a visual perception on where the TDs will introduce improvements.

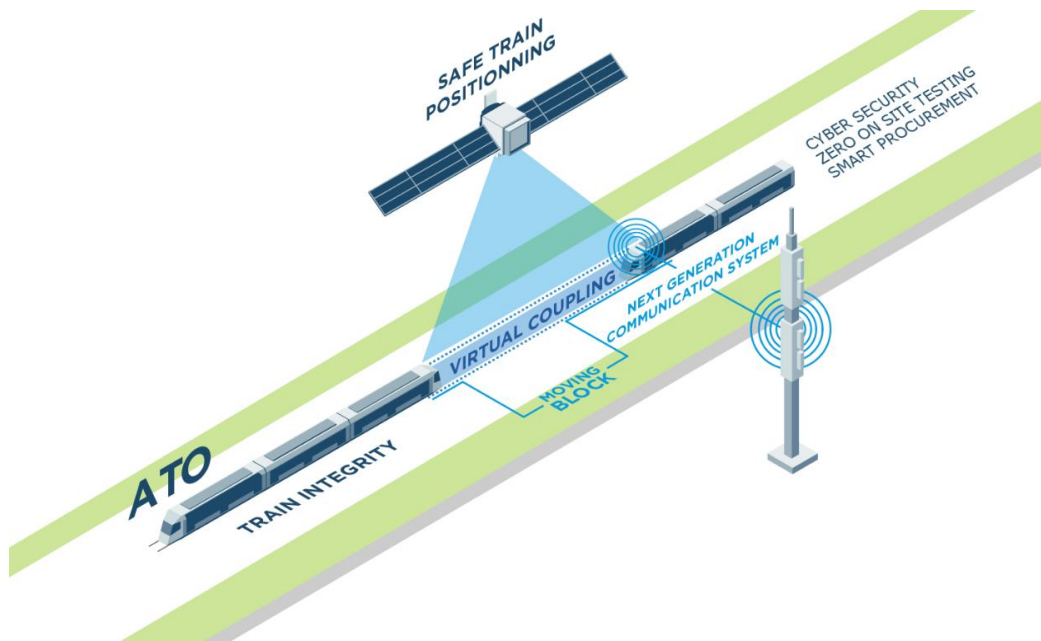

The aim of IP2 is to design and develop a control, command and communication systems that goes beyond being only a contributor to the control and safe separation of trains, and to become a flexible, real-time, intelligent traffic management and automation system.

IP2 builds on ERTMS, that, although deployed in Europe to a limited extent, including on core rail corridors, is a worldwide dominant solution for railway signalling and control systems. Current ERTMS systems do not sufficiently take advantage of new technologies and practices, including use of satellite positioning technologies, high-speed, high-capacity data and voice communications systems (Wi-Fi, 4G/LTE), automation, as well as innovative real-time data collection, processing and communication systems. These have the potential to considerably enhance traffic management (including predictive and adaptive operational control of train movements), thereby delivering improved capacity, decrease traction energy consumption and carbon emissions, reduce operational costs, enhance safety and security, and provide better customer information - all in all, the potential for achieving major cost efficiency results for railway operations.

Key Technology Demonstrators under development in IP2 will contribute to the new release of the CCS TSI, planned in 2022. Those TDs will contribute to the ERTMS Game Changers (ATO, FRMCS, Moving Block/ETCS Level 3 and train positioning). Coordination work has started in 2019 and is expected to continue until the finalisation of the process in 2022.

The picture below shows the TDs connections and dependencies within IP1 and with other IPs and CCA.

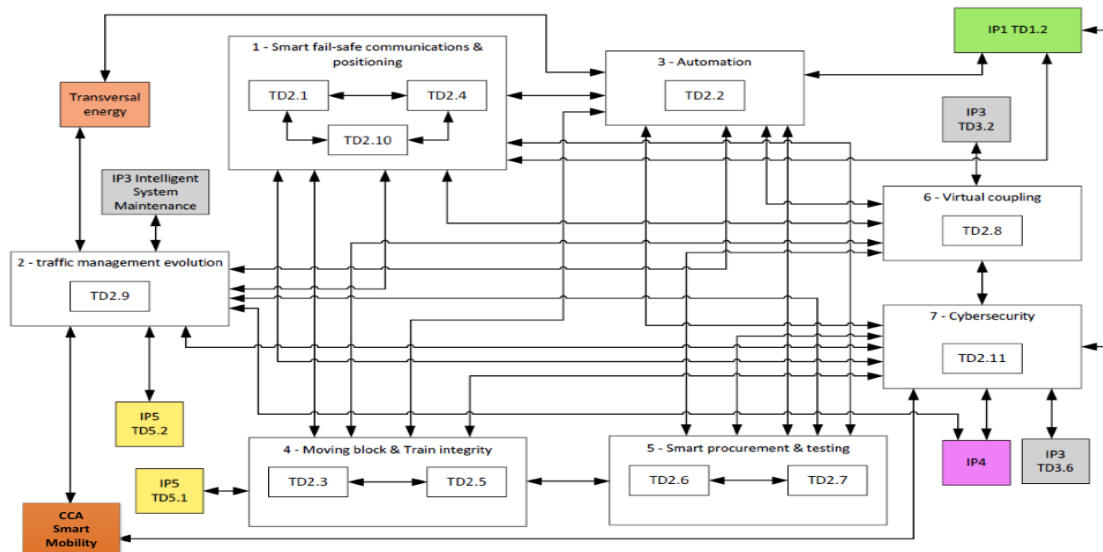

TD 2.1: Adaptable communications for all railways

The purpose of this TD is to design, develop and deliver an adaptable train-to-ground communications system using packet switching/IP technologies (GPRS, EDGE, LTE, Satellite, Wi-Fi, etc.) for supporting digital train control applications in all railway market segments. The system will facilitate migration from existing systems such as GSM-R, providing enhanced throughput, safety and security functionalities to support the current and future needs of signalling systems and well beyond; it will be resilient to interference and open to further developments in radio technology.

TD Progress

This TD builds on related activities within the following projects: X2RAIL-1, X2RAIL-3, X2RAIL-5, and AB4RAIL. The project MISTRAL was completed in October 2018, EMULRADIO4RAIL in November 2020.

The main achievements of 2021 are the following:

- Selection of test tracks by infrastructure managers and demonstrator leaders for the field tests.
- Delivery of a harmonized Field Test plan for the field tests of the three demonstrators.
- Detailed specification of test equipment and test set-up of each demonstrator.
- Preparation for final configuration and for shipment of equipment.

Based on the activities performed to date, three demonstrators with integrated prototypes are in the preparation phase for the field tests planned in 2022 in France, Germany, Italy and the United Kingdom.

Each of the three demonstrators will be validated in the field, covering the Railways Segments High-speed/Mainline, Regional/Freight and Urban/Suburban.

A harmonized test plan was defined, which will guide the field tests. As part of the test plan, the different test tracks of the involved Infrastructure Managers were described including the planned test set-up on train and trackside.

Interconnections between different partners’ laboratories using simulators and emulators are used for preparing the field tests. Remote access to the different laboratories was still key to be able to continuously validate the integration of prototypes and proceed with the lab-tests in 2021, in the context of the Covid-19 pandemic.

The delivered field test plan includes validation of all main technical concepts described in the System Specification of the Adaptable Communication System (ACS). Communication at the application level is independent from the underlying radio technology. Different options for an application interface for the ACS were evaluated. In cooperation with the Cybersecurity TD, IT security requirements defined in a protection profile were evaluated for each demonstrator.

Collaboration with the IP2 Open Call project AB4RAIL already generated additional input for the planned update of the System Specification of the Adaptable Communication System which is due in 2023. AB4RAIL is providing assessment on the use of alternative telecommunication bearers with the aim to improve the capabilities of the ACS. Such alternative bearers include, among others, Visible Light Communication (VLC), Free Space Optics (FSO), Power Line Communications, Bluetooth 5.2, LPWAN or High-Altitude Platform Station. Assessment was made based on the following features: spectrum and frequencies (e.g., channel bandwidth, frequency band), physical characteristics (e.g., transmission transfer interval, duplex mode), data rate and efficiency (e.g., peak downlink/uplink data rate, average throughput), mobility (e.g., maximum supported speed, measures against doppler), service quality (e.g., maximum user plane latency, jitter), coverage, etc.

Interim versions of the System Specifications have been prepared and discussed to take also into account the now available first draft of the FRMCS Functional Specification as well as the FRMCS System Requirement Specification.

Further updates of the Business Model for the adaptable communication were discussed to take into account new business scenarios.

Apart from the field tests of the TD2.1 demonstrators, the TD also contributes to preparatory work and planned field tests of the integrated demonstrator under preparation in X2RAIL-5.

In addition, an ATO driverless demonstrator including ACS was prepared and presented during the S2R Innovation Days, on 09 December 2021 in order to demonstrate the capability of transmitting voice and video data for a new function, using different telecommunication bearers (GSM-R, WLAN and LTE, including 4G).

Finally, the Technology Demonstrator continued its cooperation with the UIC project “FRMCS” (Future Railway Mobile Communication System) which led to further updates of the User Requirement Specification document and the System Specification of the ACS. This cooperation will continue in 2022 in order to ensure full alignment within the sector, ahead of the preparation of integration of the results in the Control Command and Signalling Technical Specifications for Interoperability (CCS TSI). The System Specification from TD2.1 was discussed in detail with the FRMCS project and has influenced the Functional Requirements Specification as well as the System Requirement Specification for FRMCS in 2021.

TD2.1: Adaptable communications for all railways (quality of service, interfaces to signalling)									
2015	2016	2017	2018	2019	2020	2021	2022	2023	...
		Finished: MISTRAL, EMULRADIO4RAIL X2RAIL-1, X2RAIL-3							
						Ongoing: X2RAIL-5, AB4RAIL			

In 2021, all nine planned deliverables were delivered. The overall progress is in line with the plan. TD 2.1 has reported having accomplished 100% of the planned work up to the end 2021, which represents 80% of progress of the overall TD.

TD 2.2: Railway network capacity increase (ATO up to GoA4 – UTO)

ERTMS/ETCS, the current generation of mainline signalling, faces a growing challenge to provide the performance improvements and increases in line capacity needed by (European) Main Line operators.

Using Automated Train Operations (ATO) with ETCS is an answer to this challenge. This technology is already vastly deployed in urban transport where different grades of automation are implemented including driverless and unattended operations. The objective of this technology demonstrator is to develop and validate a standard ATO up to GoA3/4 over ETCS, where applicable, for all railway market segments (mainline/high speed, urban/suburban, regional and freight lines).

TD Progress

This Technology Demonstrator currently builds on the following projects: X2RAIL-1 and ASTRAIL (completed respectively in 2021 and 2019), X2RAIL-4 launched at the end of 2019.

Regarding ATO over ETCS GoA1/2, the requests for change raised by S2R (further to interoperability tests performed on the Reference Test Bench in January 2019) have been addressed together with the European Union Agency for Railways (ERA) in the context of the ERA Extended Core Team meetings (EECT), responsible for the maintenance and update of the ERTMS/ETCS specifications.

The reports of the two pilot tests executed in 2020 in the United Kingdom and Switzerland have been delivered in March and June 2021, respectively. These reports were also used as the basis for the update of the GoA2 specifications at EECT level.

The following GoA2 specification documents have been delivered and are currently in discussion with ERA and the sector. ATO over ETCS System Requirement Specification (SUBSET_125):

- ATO over ETCS ATO-OB/ATO-TS FFFIS Application Layer (SUBSET-126)
- ATO over ETCS ATO-OB/ETCS-OB FFFIS Application Layer (SUBSET-130)
- ATO over ETCS ATO-OB/TCMS FFFIS Application Layer (SUBSET-139)
- ATO over ETCS ATO-OB/ORD FFFIS Application Layer (SUBSET-140)
- ATO over ETCS Interface Specification - Communication Layers for On-board Communication (SUBSET_143)

In parallel, the TD has continued working on the System Requirements Specification for Automatic Train Operations up to Grade of Automation 4 (unattended train operations), further elaborating on the following chapters:

- The operation contexts and the associated actors;
- The operation Use Cases;
- Logical Architecture;
- Interface definition;
- Users interface principles;
- The functional requirements allocated to the Logical Architecture;
- Interface specifications (FIS level) between the Logical Components.

The preliminary GoA3/4 specifications have been delivered in December 2021 and will constitute the basis for the continuation of the work in 2022. The work on the detailed specification required for prototypes development has been performed in the second half of 2021.

Finally, in December 2021, the TD successfully demonstrated a proof of concept for driverless operations during the S2R Innovation Days event. This will pave the way for the future activities foreseen on ATO GoA3/4.

TD2.2: Railway network capacity increase (ATO up to GoA4 – UTO)									
2015	2016	2017	2018	2019	2020	2021	2022	2023	...
			Finished: X2RAIL-1, ASTRail,				Ongoing: X2RAIL-4		

In 2021, the TD has delivered all three expected deliverables. TD 2.2 has reported having accomplished 100% of the planned work up to the end of 2021, which represents 70% of the overall TD.

TD 2.3: Moving Block

Improving line capacity by decoupling the signalling from the physical infrastructure, and removing the constraints imposed by trackside train detection is the key objective of this technology demonstrator. This will allow the transit of more trains on a given (main) line, especially for high-density passenger services. The system is expected to be compatible with existing ERTMS specifications and will enable progression towards CBTC (Communication Based Train Control) functionalities for urban applications.

TD Progress

This TD is currently building on the following projects: X2RAIL-5 and PERFORMINGRAIL, both launched at the end of 2020. X2RAIL-1, X2RAIL-3, ASTRAIL and MOVINGRAIL were also contributing to the work of the Technology Demonstrator.

In 2021, the TD completed the document addressing the testing of Moving Block systems, updated System Requirements, Operational and Engineering Rules and Safety Analysis, and created a report on Future Moving Block systems:

- The updated System Requirements reflect validation of the work from X2Rail-1 via the examination of a number of “Use Cases”, and examination of number of specific topics, including Track Status and Margins. There are now much more clearly described in the updated documents;
- The updated Safety Analysis now includes the results of the Risk Analysis;
- The report on the Future Moving Block systems is a summary of the work in progress to move beyond the assumed baseline in the other documents, which is ETCS Baseline 3 Release 2 plus Change Request 940 on Train Integrity.

Four Moving Block demonstrators were created by the supplier members of the TD.

The current work in X2Rail-5 represents the final round of improvement to the Moving Block specification. Within 2021, the TD has been focusing on answering some of the open points remaining at the end of the work in X2Rail-3. This task is nearing completion, and a new internal draft of the specification has been completed at the end of 2021. The next phase of work will be the re-assessment against the different Use Cases identified in X2Rail-3. The final deliverable will be available at the end of 2022. This will specify the behaviour of the ETCS Trackside in Level 3 Moving Block, together with Operational and Engineering Rules and safety analysis.

In addition, during the year, work has been done to define the content of the three Moving Block demonstrators, which are to be delivered by the end of 2022.

On the side of the ongoing complementary project, PerformingRail, work in 2021 has focused on the following axes:

- The analyses and enhancement of principles and system specifications defined by S2R X2Rail-1 and X2Rail-3 to enable safety and standard performance levels of moving block operations.
- Guidelines for moving block modelling, including the parameters and the variants of the moving block implementations and relevant scenarios.
- The mathematical definition of the Location algorithms underlying the UUDP and sensor fusion.

In addition, the Location algorithm software and 2 units of the multi-frequency/constellation GNSS receiver were on track to be finalised by the end of 2021. The next phase of work will support the implementation of a simulation-based hardware-in-the-loop platform for integrated testing, assessment, and demonstration of defined moving block specifications, formal models, train localisation and traffic management algorithms.

TD2.3 Moving Block										
2015	2016	2017	2018	2019	2020	2021	2022	2023	...	
		Finished: X2Rail-1, ASTRail, X2Rail-3, MOVINGRAIL								
						Ongoing: X2RAIL-5, PERFORMINGRAIL				

In 2021, the TD has delivered the two expected deliverables. TD 2.3 has reported having accomplished 100% of the planned work up to the end of 2021, which represents 75% of the overall TD. The overall progress appears to be in line with the plan.

TD 2.4: Fail-Safe Train Positioning (including satellite technology)

This Technology Demonstrator aims at developing an innovative Fail-Safe Train Positioning (FSTP) system, using Global Navigation Satellite Systems (GNSS) as the preferred technology to compute absolute positioning.

Currently, two possible approaches towards introduction of satellite-based positioning technology for railways are being analysed. On one side, the FSTP is as a functional block of the current core of ERTMS/ETCS and absolute positioning is based on the Virtual Balise (VB) concept, reducing the impact on current specifications. On the other side, the FSTP is a stand-alone subsystem that calculates the train travelled distance, speed, and absolute train position via an enhanced, safe, multi-sensor apparatus.

Both approaches aim at enabling the use of new technologies to boost the quality of train localisation and integrity information, while also reducing the overall life cycle costs, particularly by enabling a significant reduction in all conventional trackside (train) detection systems, such as balises, track circuits or axle counters.

TD Progress

In 2021, this TD was implemented by the following projects: X2Rail-2 (completed in April 2021), X2Rail-5 and PERFORMINGRAIL, the latter two launched at the end of 2020.

For X2Rail-2 the remaining activities were completed which aimed at deepening and improving the Proof of Concepts for the two work Streams:

- Stream1 – focused on the Fail-Safe Train Positioning Solution based on the Virtual Balise concept;
- Stream2 – focused on the Stand-Alone Fail-Safe Train Positioning solution.

Concerning the first work Stream, the following activities have been carried out:

- Open gaps in some technical solutions deemed to be used for the FSTP solution were addressed; in particular digital maps issues and related survey procedures;
- Wider description of main System Feared Events (according to the ESA classification) including focus on their impact on the signal and ways to modelling and finally simulate them by using GNSS Radio Frequency generator equipment;
- Description of possible methodologies for the environment analysis and detection for Local Feared events (namely Multipath and EMI).

Finally, an improvement of the Proof of Concept has been performed also aimed at possible dissemination events.

Concerning the second work Stream, the following activities have been carried out:

- Laboratory testing framework enhancement for the ground truth generation based on a digital map and the theoretical behaviour of train dynamics for speed, IMU sensor (including gyroscope and gravity acceleration integration) and absolute positioning;
- Laboratory testing framework enhancement for the absolute position validation where tools to automatize the outcomes from an algorithm has been carried out.

X2Rail-5 (ending in mid-2023) aims at completing most of the remaining activities foreseen in TD 2.4 by bringing the work to higher TRL levels, for the defined demonstrators.

A dedicated activity aims at defining an interoperable solution for the Satellite-Based Fail-Safe Train Positioning system, through the continuation of the work done in previous projects. Interaction with other projects and collaboration with relevant organizations (ERA, EUSPA, ESA, etc.) is also managed within this activity.

During 2021, the following activities were performed:

- A Gap Analysis has been conducted to highlight the gaps to be closed for reaching full TSI readiness, by evaluating currently existing information on possible solutions for the FSTP system against expected target. Based on this analysis, the key items have been identified and will be explored in more detail in the next phases of the work, for supporting the introduction of the localization function in the Control-Command and Signalling (CCS) Technical Specification for Interoperability (TSI).
- Close cooperation with the Joint Working Group, set up at the beginning of 2021 with the ERTMS Users Group, on the analysis of relevant Standardisation topics, such as Digital Map

(DM) and GNSS Augmentation, providing technical feedback on the set of technical specification provided by ESA/ESSP for the standardization of information to be transmitted from trackside to the on-board unit for inclusion of EGNOS in the CCS TSI.

Another stream of activity is dedicated to the finalization of the activities carried out in previous projects concerning the development of VB Train Positioning System demonstrators.

Regarding the second stream of the work, the following activities were carried out:

- Preparation of trial sites and/or laboratory environments to support the demonstrator development activities and testing;
- Actual development of demonstrators (including prototypes for early testing and dissemination purposes);
- Technical review of requirements and specifications from X2Rail-2, according to the demonstrators’ needs, in order to provide proper inputs for the standardization task for the TD;
- Deepening of technical solutions defined in X2Rail-2, with specific focus to the Ground Truth concept, as well as on Performance Indicators (both for the environment and demonstrators output), to be used for testing and overall results analysis;
- Technical review of test specifications from X2Rail-2 in order to prepare a consolidated base for the updated test scenarios (regarding the state of the art from previous activities).

Finally, for the final stream of the work, the objective was to finalize the activities concerning the development of Stand-Alone Fail-Safe Train Positioning System. The core activity is focused on demonstrating the feasibility of a multi-sensor fusion algorithm with the focus on providing support to the definition of an interoperable solution for a stand-alone train positioning system, more specifically:

- Laboratory test upgrades to support error insertion from multiple sources including:
 - Synthesize digital map,
 - Error insertion for IMU sensors,
 - Error insertion for speed sensor,
 - Error insertion for GNSS receivers.
- Definition and description of trial sites including trains to be used, tracks where the demonstrator is taking place, installed sensor configuration and the algorithm’s high-level description.
- Review of the Proof-of-Concept SRS definition from X2Rail-2 as a basis for all demonstrators of the work package.
- Test scenario definition is being defined along with the Key Performance Indicators (KPIs) to measure the quality of the algorithm performance.
- Standardised file definitions for ground truth and algorithm solution to allow an open data analysis process.

TD2.4: Fail-Safe Train Positioning (including satellite technology)									
2015	2016	2017	2018	2019	2020	2021	2022	2023	...
			Finished: X2Rail-2; ASTRail, GATE4Rail				Ongoing: X2RAIL-5, PERFORMINGRAIL		

In 2021, the TD has delivered the two expected deliverables. TD 2.4 has reported having accomplished 100% of the planned work up to the end of 2021, which represents 60% of the overall TD.

TD 2.5: On-board Train integrity

This Technology Demonstrator aims at specifying and prototyping an innovative on-board train integrity solution, capable of autonomous train-tail localisation, wireless communication between the tail and the front cab, safe detection (SIL4) of train interruption and autonomous power supply functionality without the deployment of any fixed trackside equipment. This functionality will be developed for those market segments (e.g. freight and low traffic lines) lacking such functions.

TD Progress

This TD is currently built on the progress of X2Rail-4 (launched in 2019) and X2RAIL-2 (completed in 2021).

The main achievements in 2021 include:

- Simulators and testing environments setup for functional and performance analysis as zero-site testing approach:
 - o Data about a demonstrator (i.e. parameters for integrity criteria, wireless communication features, train data, trackside data) provided as the input setup a simulator based on UPPAAL model;
 - o Formal model and simulator in UPPAAL for product class 3 for formal verification and performance analysis was developed in addition to the setup of a RANSS simulator with train data and trackside data selected by members for on-field testing.
- TRL6-7 demonstrator's definition, implementation and laboratory testing for on-board train integrity monitoring and train length determination. Preparation activities for installation and site testing:
 - o A demonstrator for OTI Product Class 1 was defined based on wired communication, defined laboratory test environment and test plan, identified experimental train and experimental line in Czech Republic. Train length determination is based on configuration parameters (i.e. waggon length and identifier) hosted within OTI devices installed on each waggon. Train integrity criteria are based on the liveness of the communication. An End of Train device is installed in the last waggon.
 - o A demonstrator for OTI Product Class 2 was defined based on ACS gateway for Train to Train (T2T) and Train to Ground (T2G) wireless communication, odometric data acquisition from ETCS and communication with TMS. OTI device is installed only at head and train cabins, connected to ETCS. Laboratory test environment defined and implemented. A laboratory test plan was defined and the OTI, TMS, ACS Gateway integration was completed. The integrity criteria tested with odometric data from real ETCS. Train and trackside for on-field testing identified, on-board electrical design and mechanical layout defined, preliminary test plan for on field-testing defined. An OTI dashboard allow configuring OTI system and showing Finite State Machine status, train integrity status and train length determination.
 - o A demonstrator for OTI Product Class 3 was defined based on wireless communications for train composition determination and comparison with TMS train composition data. Train length determination based on configuration parameters hosted within OTI devices installed on each waggon. Multiple sensors were adopted to detect separation between adjacent waggons. Results shown on OTI Dashboard include discovered train composition, evaluated train length and integrity status. Train and trackside for on field-testing was identified and a test plan was defined.
- Fault tree analysis to evaluate the quantitative safety requirements for the three defined OTI product classes and train length determination was performed.

- Preliminary analysis to define OTI-Digital Automatic Coupler (DAC) integrated solution. The collaboration was launched during the year with the representatives from the European DAC Delivery Programme (EDDP), with the objective for the DAC to potentially integrate the solution developed by the OTI TD. The work will continue in 2022.

TD2.5: On-board Train Integrity									
2015	2016	2017	2018	2019	2020	2021	2022	2023	...
Finished: X2Rail-2; ETALON					Ongoing: X2RAIL-4				

In 2021, the TD has delivered the two expected deliverables. TD 2.5 has reported having accomplished 100% of the planned work up to the end of 2021, which represents 75% of the overall TD.

TD2.6: Zero on-site testing (control command in lab demonstrators)

The development of a new laboratory test framework comprises simulation tools and testing procedures for carrying out open test architecture with clear operational rules and simple certification of test results. It aims at minimising on-site testing (with the objective of Zero On-Site Testing - ZOST) by setting-up full laboratory test processes, even when systems comprise subcomponents of different suppliers. The test framework will also allow remote connection of different components/subsystems located in various testing labs.

TD Progress

The activities related to this TD were started under X2RAIL-1 and the first results have been ready since December 2018. These results include a benchmarking analysis, the description of the test process and the definition of a full system test architecture for the necessary test environment to support shifting testing from the field to the lab. In this timeframe the results of the VITE open call have been jointly analysed and taken into account.

The TD continued the activities in 2019 as part of the X2Rail-3 and GATE4RAIL projects working on the following milestones finishing in 2020:

- definition of a generic communication model,
- data modelling for the test environment,
- validation of data with formal methods.

In 2021, as part of the X2Rail-5 project, the test architecture defined in previous projects has been rigorously analysed to confirm that it is flexible enough to cover all the Zero On-Site Testing requirements. All of the new subsystems to be included in the testing architecture have been identified, according to the prototype development activities foreseen in the project, together with the needs of other technical demonstrators. A series of workshops with all the representatives of the technical demonstrators were held to share with them the requirements of ZOST, the architecture and the testing model, and to take into account the suggestions and possible changes emerging from their work.

Based on these results, especially the Moving Block and ATO testing activities have been included within the Zero On-Site Testing architecture, with the definition of the new interfaces and related specification(s). This was done as an update of the existing FFFIS/Subset 111 and by the creation of new documents:

- FFFIS for TCL - ATO-OBU adaptor
- FFFIS for TCL - ATO-TS adaptor
- FFFIS for TCL -Train Simulator, for Train Simulator – OBU Adaptor and for Train Simulator – ATO-OBU Adaptor

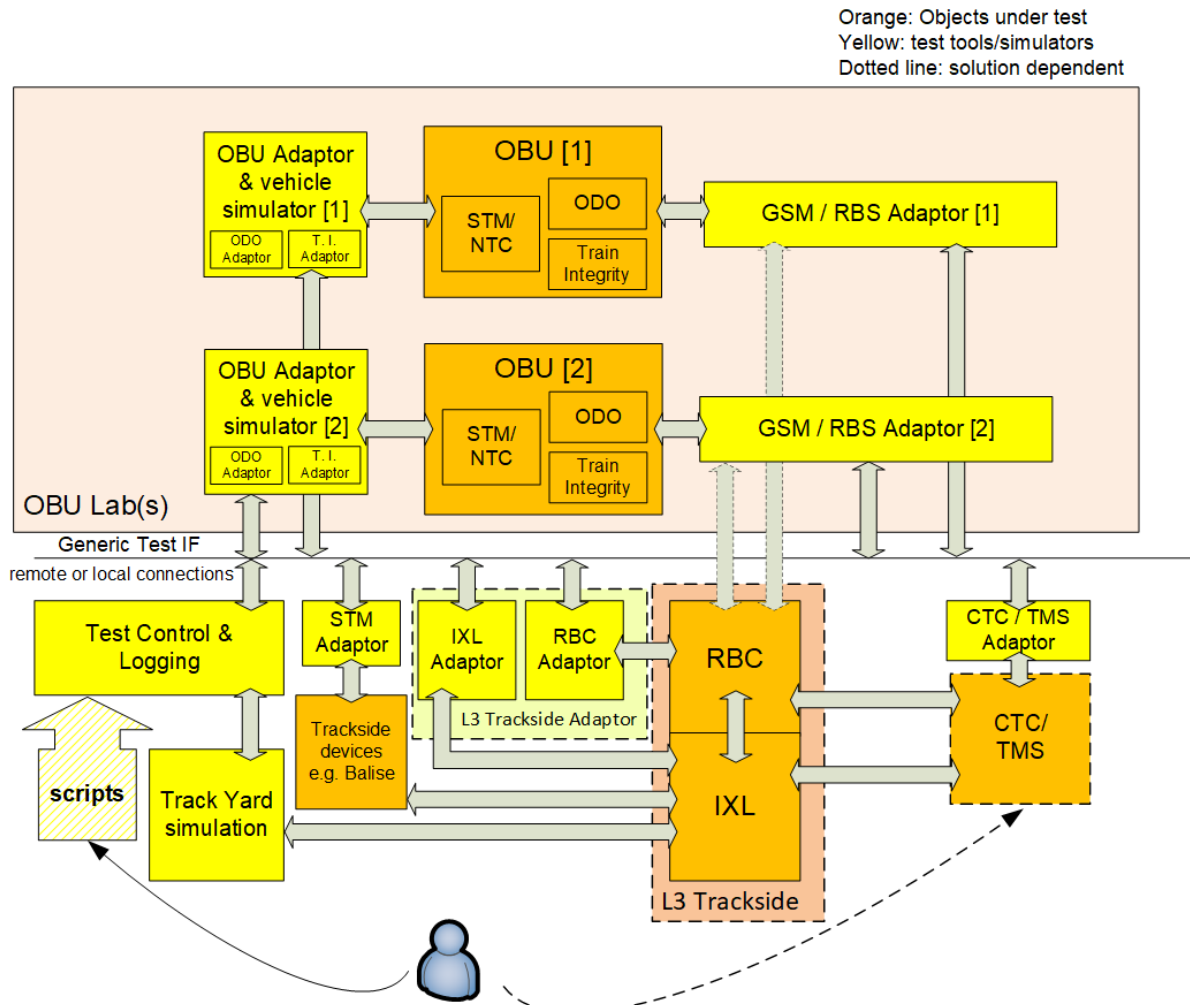

Use case "Environment for validation of Moving Block"

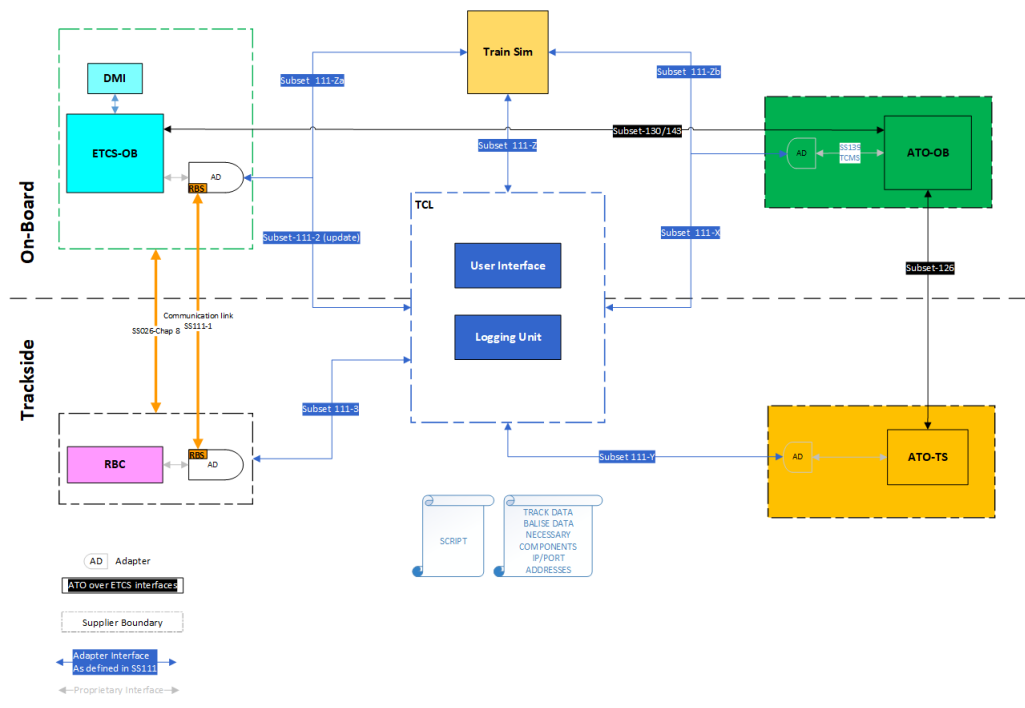

ATO Testing Architecture

In 2021, the TD focused on the update of the test architecture defined in X2Rail-3 with the addition of a new set of standards related to the connection of TMS and PIS to exchange disruption management related information. This will support the objective to define standard data exchange inside the test environment.

The deliverable was prepared to cover the FFFIS standard to be used and the required automated test procedures for testing the connection of TMS and PIS based on the relevant (selected) test cases. By having undertaken an assessment of available communication standards for interfaces between TMS and PIS, it was decided to use the existing and well-established interface standard CEN/TS 15531 Service Interface for Real-time information (SIRI).

Thirdly, another area of focus was the analysis of system boundaries for the distributed Lab and the feasibility for Digital Twin concepts in Zero On-Site Testing.

The boundary analysis compared these boundaries with the goals of Zero On-Site Testing and the potential business impact. A list of potential boundaries was created and analysed. Additionally, the impact of the distributed lab may have on the input data was analysed as well as finding solutions to mitigate against this impact.

Part of the Digital Twin Feasibility Study was the analysis of the applicability of different digital twin approaches for their usage in the railway sector for Zero On-Site Testing. Based on the very specific expectations from Zero On-Site Testing a definition was developed. In addition, possible Use Cases for implementing Digital Twin concepts in the existing test architecture were derived respectively Use Cases for expanding the test architecture were defined.

TD2.6: Zero on-site testing (control command in lab demonstrators)									
2015	2016	2017	2018	2019	2020	2021	2022	2023	...
Finished: X2RAIL-12, X2RAIL-3, VITE, GATE4RAIL						Ongoing: X2RAIL-5			

In 2021, the TD has delivered all three expected deliverables. TD 2.6 has reported having accomplished 100% of the planned work up to the end of 2021, which represents 75% of the overall TD.

TD2.7: Formal methods and standardisation for smart signalling systems

Formal methods (FMs) provide the means to establish the correctness of a system model with respect to given properties, to improve verification, certification, and authorisation processes, while reducing the need for extensive field tests in the future. To verify safety is considered one of the most compelling use cases for FMs. FMs and standard interfaces aim to contribute to reduced life cycle cost and time-to-market, increased market competition and standardisation, and improved interoperability and reliability. While standard interfaces are orthogonal to formal methods (one can use one without the other), they help increase competition, and enable more efficient use (and reuse) of formal methods.

TD Progress

This TD builds on the following projects: X2RAIL-5, PerformingRail (both launched in December 2020) as well as on X2RAIL-2 and 4SECURail (completed in 2021). The open call PerformingRail will apply formal modelling and optimal traffic management to moving block with advanced train positioning, to mitigate potential hazards. The open call 4SECURAIL provided a cost-benefit analysis (CBA) for FMs, assessment of key topic ‘learning curve’, and a case study (for an RBC/RBC handover interface, based on UNISIG specifications SUBSET-039 and SUBSET-098).

TD 2.7 will apply FMs at the system of systems (SoS) level for deeper analysis of moving block requirements defined by TD 2.3 (validate consistency, find mistakes, propose improvements, etc.). Another related objective is to identify suitable FMs approaches to meet the needs of future Functional Railway System Architectures.

TD2.7: Formal methods and standardisation for smart signalling systems									
2015	2016	2017	2018	2019	2020	2021	2022	2023	...
			Finished: X2Rail-2, ASTRail, 4SECURAIL						
						Ongoing: X2RAIL-5			

In 2021, TD 2.7 has accomplished 100% of planned work up to the end of 2021, which represents 81% of the total calendar time planned for TD2.7 in X2R-5.

TD2.8: Virtually – Coupled Train Sets (VCTS)

This TD addresses the increment of network capacity, beyond the limitation of the current signalling approach for train and units separation. Increased capacity is today needed for many networks in Europe. Building new lines or adding tracks to existing lines is a slow and expensive process. Furthermore, decoupling, shunting, and coupling is a key feature of the traditional railway system. Virtual Coupling can help to bolster the competitiveness of rail as regards flexible and timely operation on demand.

In this context, this TD aims at defining the overall functional, performance and safety analysis of the VCTS, providing a feasibility analysis, addressing system requirement specification, finally evaluating system impact analysis and proposing a business case.

TD Progress

This TD currently builds on the progress of the following projects: X2RAIL-3, completed at the end of November 2021 and MOVINGRAIL, completed at the end of 2020. The TD activities were closed with the completion of X2RAIL-3.

The following achievements were reached in 2021:

- System Requirements Specification:
 - o The TD performed the VCTS system requirement specification based on operational scenarios, functionalities, and related safety analysis. Hierarchical traceability approach was applied to derive requirements for VCTS-On-Board and VCTS Track-Side functional blocks and related interfaces with other sub-systems (e.g. ATP, ATO, TMS);
 - o Specification approach is independent from any specific technology. An ETCS application has been evaluated underlining, for example, the functional implications at RBC level (e.g. platoon movement authority and position report messages) and TMS level (e.g. platoon composition and timetable transmitted over Integration Layer).

- System Impact Analysis:
 - o The System Impact Analysis was performed on the system requirements specifications, as explained above;
 - o The Impact analysis evaluated the technical and non-technical implications for two different application cases: VCTS standalone and ETCS. The first case refers to lines currently operated with legacy train protection systems that are subject to obsolescence issues in the near future, whereas the second evaluates the integration of VCTS functionality in ETCS;
 - o Necessary modifications have been identified and the possible expected range of impact on systems outside of VCTS, such as TMS, ATO, ATP, Communication, etc., have been quantified;

- System Business Model:
 - o Migration plans for the two application cases identified have been defined. For ETCS application case, guidelines for embedding VCTS functionality in RCA/OCORA reference architecture have been also proposed;
 - o The German network was considered as a VCTS application example.

TD2.8: Virtually – Coupled Train Sets (VCTS)										
2015	2016	2017	2018	2019	2020	2021	2022	2023	...	
				Finished: X2Rail-3, MOVINGRAIL						

In 2021, TD 2.8 delivered the four expected deliverables. The TD reports 100% completion for the year 2021 and 100% completion of the overall activities. The TD is now completed.

TD2.9: Traffic management evolution

The goals of a future Traffic Management System are to improve traffic management operations with new advanced applications, automated processes for decision making leveraging on interoperable data integration, and exchange with other rail business services via the Integration Layer.

TD Progress

This TD currently builds on the work performed in X2RAIL-2 (concluded in 2021), X2RAIL-4 and OPTIMA, both launched at the end of 2019.

The development of an interoperable communication structure requires an interoperable Data structure. Such a platform-specific Data Model (PSM) for Traffic Management has been developed in collaboration with the projects FINE2 and OPTIMA. The designed Model covers all operations and domains of Passenger & Freight Rail Transportation. The data structure will be further optimized and enhanced alongside the development of the demonstrators. The PSM is managed as a WIKI database including class-diagrams for all domains, code examples for the data structures, 4 different API types (REST, STOMP, Java and C) and various application documents. This so-called X2Rail-4 Model has been delivered to the IPX project LINX2Rail, representing the only complete source concept used to specify a Platform independent Data Model (PIM).

7 Demonstrators addressing Connected Driver Advisory System (C-DAS), Wayside ATO (WATO), general TMS Business Applications such as Dispatching, Conflict Detection & Resolution, Possession Management, presentation of Field Data (Signaling) and Data Integration of different business services e. g. Weather Information and User Interfaces were developed up to TRL 4 and tested.

The results achieved to date are the following:

- the Integration Layer to serve as an excellent solution for an integrated communication platform applying publish & subscribe messaging methodology linking the different legacy and new business services/clients via the APIs specified under the CCA CFM, FINE2;
- the platform-specific Data Model for TMS for Traffic Management operations as a key element for interoperable Data exchange including the demonstrators of Optima;
- the achievement of the targeted objectives with regard to integration of data supporting together with Data integration the precision of decision processes especially for dispatching and conflict detection & resolution and new application such as C-DAS and WATO.

The TD continued with the design and specification of new traffic management functionalities based on use cases developed in the previous project, updating the use cases to include degraded mode scenarios. Developing deep learning algorithms in combination with existing technology for large-scale network optimisation, including conflict detection and resolution. In connection with this work, it was investigated how to display the information related with the large-scale optimisation to operators and visualizing the information and interacting with the system, as well as how such a system could be tailored to different operators.

In addition, the TD is working on ways to better measure workload and situational awareness of control centre operators. The work of operators has very large variations in terms of workload, so the task and HMI need to be carefully designed to keep operators engaged but avoid overload. These results will contribute to better understand their tasks and how to design operator's role and HMI.

OPTIMA aims at developing and validating a demonstrator platform for Traffic Management which links TMS applications with signalling field infrastructure. In 2021, OPTIMA finalized its platform requirements specification and almost its development of the different modules of the platform: Integration and Persistence Layer, Rail Business Services, Operator Workstations, Application Framework and Conceptual Data Model. Collaboration with X2Rail-4's partners involved in the development of Traffic Management System prototypes was mainly established in the definition of the Conceptual Data Model implemented in OPTIMA as a showcase of the final CDM which will be developed by LINX4RAIL. OPTIMA used the Platform Specific Model (PSM) developed by X2Rail-4 as a

basis to implement and complement the Platform Independent Model (PIM). Final integration of some TMS prototypes into the demonstrator platform is expected in 2022 to prove and validate platform capabilities and interoperability.

A Joint Steering Board has been established between the two projects for technical alignment. OPTIMA is implementing a complete Integration Layer Infrastructure. All requirements of OPTIMA implementation regarding data structures are integrated into the X2Rail-4 Data Model.

TD2.9: Traffic management evolution									
2015	2016	2017	2018	2019	2020	2021	2022	2023	...
Finished: X2Rail-2					Ongoing: X2RAIL-4, OPTIMA				

In 2021, the TD has delivered 4 of the 11 expected deliverables. TD 2.9 is reporting having accomplished 36% of the planned work up to the end of 2021, which represents 68% of the overall TD.

TD2.10: Smart radio-connected all-in-all wayside objects

The objectives of this technology demonstrator are to develop an autonomous, intelligent, maintenance-free smart equipment (“box”) able to connect with any signalling wayside object and communicating device in the area (wireless), guaranteeing safety and security, by the definition of a common architecture and of requirements and interface specifications. The TD will develop concepts for locally derived power, for the overall reduction of power consumptions and required cabling as well as to specify interfaces with control, power, diagnostics and maintenance systems using both low and high-capacity wireless links.

These “intelligent” objects - knowing and communicating their status conditions - would not only provide opportunities in terms of cost reduction and asset management improvement, but also establish new means for management and control of railway network information.

TD Progress

This TD currently builds on the following projects: X2RAIL-1, ETALON (both completed in 2019), and X2RAIL-4, launched in December 2019.

In 2021, the TD focused on the Development and Verification of selected demonstrators and in the Analysis and Evaluation of the demonstrators at TRL4 and the completion of Linx4Rail action for SWOC (Smart Wayside Object Controller)/RCA/EULYNX alignment.

The Development and Verification of selected demonstrators at TRL4 uses as inputs deliverables coming from the previous project, X2RAIL-1.

The main focus of the demonstrators was to develop and test them in a laboratory environment (TRL 4) against the requirements to cover the use cases described in the following table:

Use Case	Existing OCs	SWOC	Demonstrator
IXL control management	✓	✓ (A)	✓ (A)
OBU Interface with SWOC	✗	✓ (O)	✓ (P)
TMS interface with SWOC	✗	✓ (O)	✓ (P)
SWOC distributed Architecture	✗	✓	✓
Safety Conditions	✓	✓	✓
Power Management	✓	✓ (A)	✓ (A)
Management of SWOC deployment	✗	✓	✓
Communication Management	✓	✓ (A)	✓ (A)
Security	✓	✓ (A)	✓ (A)
Maintenance Management	✓	✓ (A)	✓ (A)
Diagnosis Management	✓	✓ (A)	✓ (A)
Asset Management	✓	✓ (A)	✓ (A)

✓ OK: Available ✗ NOK: Not available ✓ (A) OK (Advanced): available and improved ✓ (O) OK (Optional): available only if desired ✓ (P) OK (Partially): Partially available

Also, different operational scenarios, in terms of market segments, types of wayside element controlled, communication type, control entities, diagnosis & maintenance features and power management have been defined. At least one sub-demonstrator shall cover the use case of each type of wayside element.

For this purpose, eight different demonstrators have been defined in order to cover a large spectrum of suitable scenarios, with the intention of being able to test, in greater detail and precision, each of the functionality/features to be covered by the SWOC.

1. Wireless Low Power Object Controller demonstrator;
2. Track vacancy detection SWOC demonstrator;
3. Cable-Less Railway Embankment Demonstrator;
4. Multiple Networks Scalable SWOC;
5. Smart Wayside Object Controller;
6. Gate Signal Smart Wayside Object Controller;
7. Wireless, Advanced Diagnosis, Intelligence distribution and Low-Power Consumption;
8. New generation of adaptable Wireless sensor Network for way side objects in railway environments.

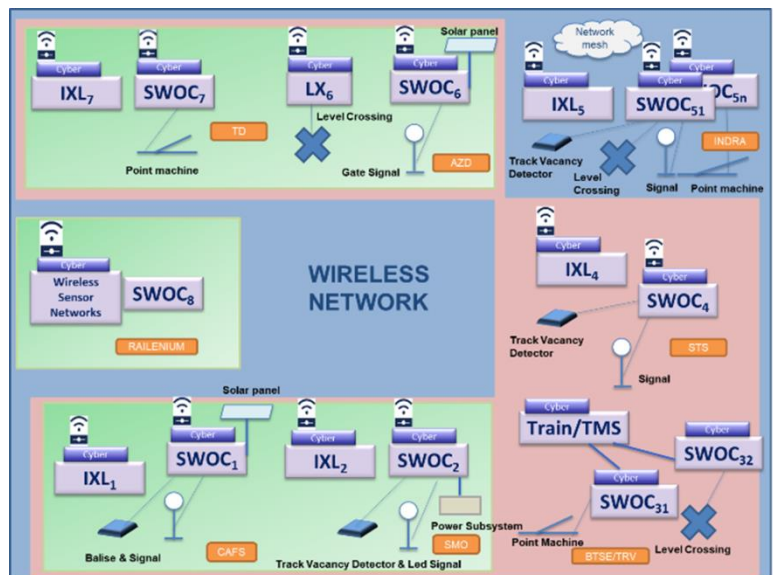

For each demonstrator the following information is provided:

- Description demonstrator including use cases, functional architecture and test environment.
- Production of test cases and assessment cases, including the traceability with requirements.
- The results of the tests of each demonstrator.

The system requirements coverage and system architecture compliance and external interfaces of the overall demonstrator at TRL4 is also included.

The analysis and evaluation of the demonstrators aims at performing a review analysis of the work done per each demonstrator at TRL 4 and drawing conclusions from it, to optimize the prototypes.

The different TRL4 demonstrators implemented are building the basis for further activities to be carried out until 2023. The aim is to further enhance the demonstrators in an operationally representative environment to reach Technology Readiness Level 6 (TRL6).

Additionally, as a result of the study requested by Linx4Rail Action on SWOC/RCA/EULYNX alignment, possible orientations are defined for EULYNX/RCA to include SWOC's innovative solutions in the standardization work:

- Wireless communications;
- Efficient energy management;
- Distributed architecture (logical distribution and additional interfaces);
- Multiple object controllers.

From the SWOC side, it was agreed to use the OPC-UA protocol for the specification of the Diagnostics interface and to be demonstrated in one of the demonstrators.

TD2.10: Smart radio-connected all-in-all wayside objects									
2015	2016	2017	2018	2019	2020	2021	2022	2023	...
		Finished: X2Rail-1, ETALON				Ongoing: X2RAIL-4			

In 2021, the three expected deliverables were delivered. The overall progress was in line with the plan. TD 2.10 reports having accomplished 100% of the planned work up to the end of 2021, which represents 85% of the overall TD.

TD2.11: Cybersecurity

The interconnected digital railway network at European level is constantly growing and will keep on growing, which will increase the number of risks associated to security. There is therefore a growing need for handling these cyber-security threats in railway systems. This technology demonstrator aims at achieving the optimal level of protection against any significant threat to the signalling and telecom systems in the most economical way (e.g. protection from cyber-attacks and advanced persistent threats coming from outside).

TD Progress

The activities of the TD are addressed via the projects X2Rail-1, X2RAIL-3, 4SECURAIL (all completed in 2021) and X2Rail-5 launched at the end of 2020.

The following activities have been completed in 2021:

- Security verification and validation testing best practices – Product lifecycle
- Security verification and validation best practices – System lifecycle
- Verification along the supply chain
- Cybersecurity evaluation of ATO, VCTS, CONNECTA
- Cybersecurity evaluation of ACS and SWOC

- Computer Security Incident Response Team (CSIRT)

Security verification and validation best practices

At product level, IEC 62443-4-1 of “Practice 5 Security verification and validation testing” requirements, and its main test methods have been reviewed and analysed in depth. Analysis have demonstrated ISA Secure® provides globally a mature component certification scheme. Best practices of security verification testing for railway business was done in the context of hardening and penetration testing.

At system level, security verification and validation requirements related to testing and non-testing activities, identified in the IEC 62443 series of standards, have been adapted to define best practices in the railway industry. These requirements, and the derived practices, have been allocated to railway systems and roles involved. Furthermore, the environmental conditions to perform security testing activities have been defined.

Verification along the supply chain

Supply-chain requirements of key security standards (ISA 62443-2-1; IEC 62443-2-4; IEC 62443-4-1; ISO/IEC 27001/2; ISO/IEC 27036 (part 2), NIST SP 800-53) have been analysed. The analysis also extended to the supply-chain requirements in the European NIS 2.0 Directive, which has supply-chain requirements applicable to Operators and IMs. It was possible to determine the main areas of focus that are applicable to the supply-chain for products, components, and services. The analysis identified the verification activities that need to take place along the supply-chain lifecycle, highlighting those activities that are critical to an organisation, including supplier qualification, audit and monitoring and product assurance.

A “Supplier Evaluation sheet” to support qualification of supplier of bespoke rail specific products and components have also been established. The sheet includes different areas of evaluation, such as secure development and secure IT/OT environments. It was developed considering the standards previously analysed. The potential of this document is to become a reference to organisations in the railway sector when they consider undertaking supply-chain security verification activities through the supply chain.

Cybersecurity application to other demonstrators: ATO, TCMS, VCTS

ATO (Automatic Train Operation): a risk assessment has been performed and the security levels to reach for the ATO trackside and onboard have been defined, along with GoA2 and GoA4. Security measures to mitigate the risks identified are proposed.

TCMS: Based on the documentation delivered by the IP CFM CONNECTA, a risk assessment and an analysis of the network architecture has been prepared. This study analyses the security risks of this new network architecture (VLAN), specifically the single ring and the “virtual” segregation. This study recommends further security requirements following the results of X2Rail-3 Cybersecurity Working group (based on generic security architecture, protection profiles for Onboard and ACS gateway components which are based on the industrial security standard IEC 62443).

VCTS (Virtual Coupling): Based on the documentation delivered by the VCTS Workgroup an initial risk assessment has been prepared.

Cybersecurity evaluation of ACS and SWOC

The goal was to demonstrate the applicability of the developed protection profiles to the Technical Demonstrators for Adaptable Communication System and Smart Wayside Object Controller components.

For each Technical Demonstrator, an assessment team was set up, to evaluate the requirements of the protection profiles. A feedback questionnaire was created to gather the feedback of the assessment teams for applying the X2Rail-3 protection profiles.

Feedback of the assessment teams was analysed to provide insights on the applicability of these protection profiles to the Technical Demonstrators.

Computer Security Incident Response Team - CSIRT

A CSIRT reference model for designing and implementing organization-wide cyber defence capabilities has been defined. The reference model provides a basic target architecture for developing cyber defence structures within a railway company to provide adequate protection against cyber-attacks. In particular, this includes the organisational model, capabilities, technologies, and interfaces for collaboration with other functions in the organization.

The model is derived from the cyber defence concept of Deutsche Bahn where it is currently being rolled out successfully. The goal is to give a guidance on how to approach this complex task of building cyber defence capabilities in an effective way. Yet, it should not be considered as a model that can be applied one to one in any context. Every principle, measure, or definition provided should be regarded as a good practice recommendation.

TD.11 : Cyber Security								
2015	2016	2017	2018	2019	2020	2021	2022	2023
	Finished : CYRAIL							
	On Going : X2Rail-1, X3Rail-3, X2Rail-5, 4SECURAIL							

In 2021, the four planned deliverables were delivered on time. The overall progress is in line with the planned activities. The TD has reported having accomplished 100% of the planned work up to the end of 2021, which corresponds to 80% of the overall progress of the TD.

1.4.3. IP3 Cost-Efficient and Reliable High-Capacity Infrastructure

The picture below provides a visual of the TDs where improvements are expected.

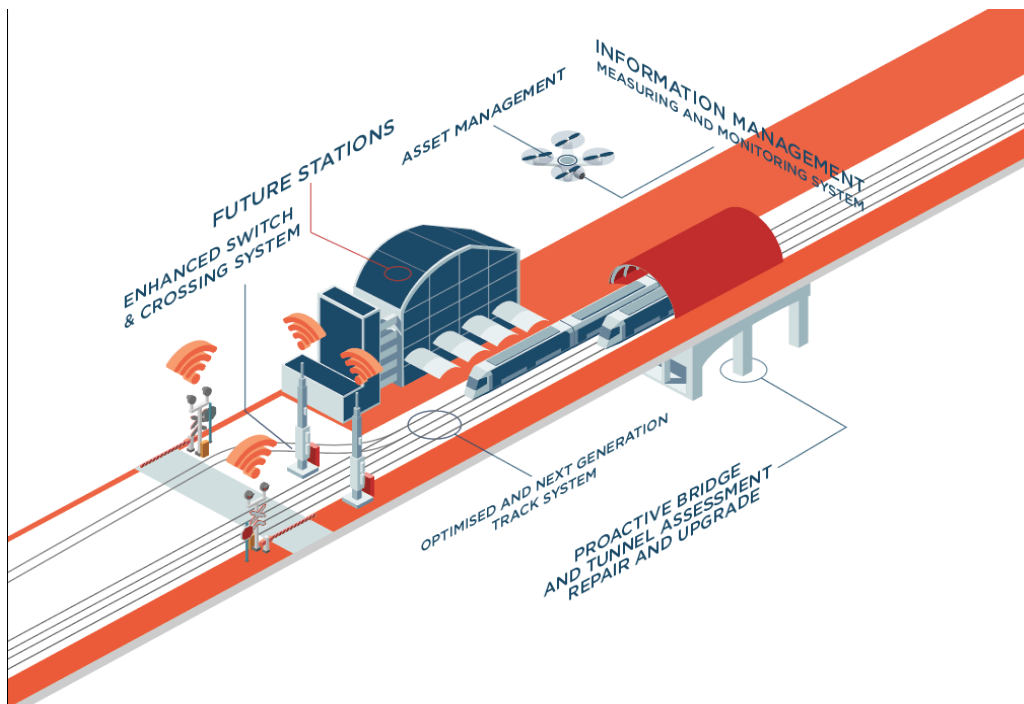

The design, construction, operation and maintenance of rail network infrastructure have to be safe, reliable, supportive of customer needs, cost-effective and sustainable. In order to deliver the benefits of market opening and interoperability and to reduce the life cycle costs of rolling stock and on-board signalling systems, the network diversity needs to be eliminated, notably through a migration towards common high-performing infrastructure system architecture.

Activities that can support the reduction of infrastructure maintenance costs, such as simplified procedures or automation, need to be led in priority. They should propose solutions that can be rapidly and efficiently deployed. Furthermore, the infrastructures have to be managed in a more holistic and intelligent way using lean operational practices and smart technologies that can ultimately contribute to improving the reliability and responsiveness of customer service, as well as the capacity and the whole economics of rail transportation.

In order to be competitive with other modes but also integrated with them, compatibility between different modal infrastructures (including multimodal hubs, changing points and stations) needs to be ensured and based on principles of interoperability and standardisation.

The picture below shows the interconnections and dependencies within the IP3.

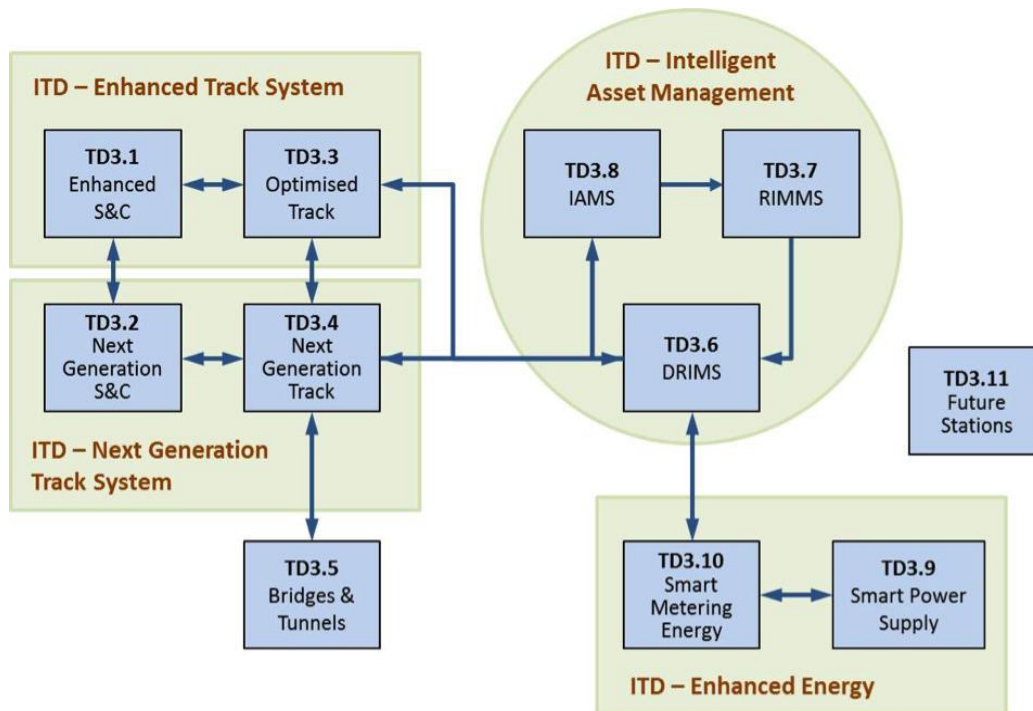

TD3.1 Enhanced Switch & Crossing System Demonstrator

TD 3.1 aims at improving the operational performance of existing Switches and Crossings (S&C) designs through the delivery of new S&C sub-systems with enhanced Reliability, Availability, Maintainability and Safety (RAMS), improved Life Cycle Cost (LCC), sensing and monitoring capabilities, self-adjustment, noise and vibration performance, interoperability and modularity.

TD Progress

TD 3.1 builds on the project's activities of IN2RAIL and IN2TRACK (past projects), IN2TRACK-2 and IN2TRACK-3.

In 2021, the **whole system modelling approach** including hybrid testing approaches for virtual evaluation and design of S&C were developed and validated with available field data.

This includes:

- a) Long-term rail damage evolution in railway crossings:
 - Influence of crossing angle on long-term rail damage evolution in railway crossings,
 - Study compared the accumulated wear and plastic deformation for the crossing angles 1:12, 1:15 and 1:18,5 over 65 MtT of traffic,
 - Plastic deformation and wear on switch panel,
 - Plastic deformation and wear on crossing nose.
- b) Structural track model with capability to:
 - Account for rail bodies with varying properties along their length,
 - Add the capability to compute bending loads in rails and sleepers has been completed.
- c) Development of vertical track geometry due to track settlement
- d) Crack initiation models considering microstructural properties

Consequently, changes of S&C sub-systems or components and their influence in the context of the rail system can be assessed. S&C system performance for pre-defined deterioration and system functions analysis can be shifted to a fully virtual environment and hybrid-testing significantly decreasing the time-to-market and innovation cycles by up to 30%.

In the future, the methodologies will be applied to predict crossing geometry degradation for the Austrian demonstrators and validate the methodologies in 2022-2023. For the structural track model script, the focus will lie on improved ballast modelling and improved numerical efficiency for full structural track models featuring non-linearities such as hanging sleepers and validated with the VARS demonstrator.

Condition monitoring approaches and monitoring procedures showcasing promising networking technologies for S&C CBM have been finalized and their performance was analyzed:

- Near Field Communication: feasibility of having an accurate positioning system of the track recording vehicle in relation to the S&C’s location developed and tested under laboratory conditions.
- In bearer sensors for crossings: measurement or estimation of dynamic forces to identify deteriorating conditions of S&C were demonstrated and validated in-track.
- Switch rail profile measuring device: hand-held device that can carry out the switch rail wear checks using state of the art technology validated under laboratory environment. Recommendations for improvements were derived and documented.
- Enhanced switch and crossing monitoring: sensors monitoring S&C demonstrator installed by VARS for validating design improvements and modifications including modelling approach was proposed to identify faults affecting the S&C condition and isolated based on technical specifications.
- Friction management approaches extending the life of rail switches as well as reducing derailment risk.
- Electromechanical impedance technique (EMI) on detecting the appearance and evolution of internal defects on manganese switch frogs.

The described technologies will be in full operation and final validation during the course of 2022 and 2023.

In 2021, the **Enhanced manganese crossing** technologies including bainitic steel components were equipped with data acquisition systems and test procedures for performance tests under an operational environment. For validation purposes a specific high-frequent track with high-tonnage in France was chosen. The tests and its assessment were postponed to 2022/2023 because of the Covid-19 pandemic.

Additionally, measurements on the fully re-designed **VARS enhanced switch & crossing** were made to show the differences between the S2R demonstration turnout and the reference turnouts. Extended Data Acquisition Systems are gathering data both of the S2R turnout and the reference turnout to continuously measure loads and to be able to assess the performance of the enhanced technologies. An extensive in-depth assessment representative for a longer period of time by means of extensive measurement campaigns was set in place and carried out until the end of the programme.

TD3.1 Enhanced Switch & Crossing System									
2015	2016	2017	2018	2019	2020	2021	2022	2023	...
Finished: IN2Rail, IN2TRACK				Ongoing: IN2TRACK 2, IN2TRACK 3					

In 2021, two planned deliverables were released. TD 3.1 has reported having accomplished 90% of the planned work up to 2021, which represents 70% of the overall TD 3.1.

TD 3.2 – Next Generations Switch & Crossing System Demonstrator

TD 3.2 aims to provide radically new system solutions that deliver novel methods for directing trains between tracks to unlock additional network capacity, while reducing maintenance needs, traffic disturbances and life cycle costs. Step-change solutions are prioritised over short-term incremental improvements. However, it must be recognised that incremental changes to the current switch and crossing design will need to be progressively introduced and a transitional approach adopted. This will enable a change from current design forms to a radical shift to a new approach in transferring trains between tracks in a 40+ year horizon view.

TD Progress

TD3.2 builds on the project's activities of IN2RAIL, S-CODE (past projects) and IN2TRACK-2 and IN2TRACK-3. In 2021, TD3.2 has reported progress on the following topics:

- Development of how the application of CSM-RA (Common Safety Method – Risk Evaluation and Assessment) needs to be implemented for the next generation switch and crossing design has been carried out through workshops adopting the bow tie methodology at a high level using concepts as a basis.
- Digital development for the next generation S&C has been progressed to a low TRL level that illustrates the planning and process requirements for the implementation of a digital twin for the next generation switch and crossing design. The work included the development of an agreed definition for a next generation S&C digital twin.
- Development of a BIM model to complement the digital twin development for S&C has continued despite no BIM standard was available. IFC rail has been used as the basis for this development. This methodology will form the basis for feeding the BIM information into the digital twin which will be designed to provide a detailed monitoring capability of the health of S&C assets. Work has achieved TRL5 with mapping of complex system-level of mapping of geometry into the virtual demonstrator as the basis to map functional/operational data onto the technology in order to achieve further TRL levels.
- A probabilistic approach for next generation S&C whole system demonstration has been developed utilising fault detection and isolation algorithms. Major emphasis has been given to point machine failure diagnosis. Bond graph methodology has been used to develop the model. This work has reached TRL5 with progress to TRL6 restricted by lack of data to validate the system.
- Development of an integrated embedded sensor system for S&C with completion of structural and functional modelling of S&C unit to aid robust fault detection: This work has progressed to TRL5 in the development of a design for an integrated embedded sensor system for S&C system condition monitoring through component trials and validation exercises that demonstrate the performance of the system.
- Novel sensor technology for S&C monitoring: Work on this task has concentrated on the deployment and use of a combination of fibre optic and acoustic sensing to understand the performance characteristics of the introduction of a composite bearer matrix to a complex junction in an operational environment and the assessment of the change in material to the overall performance of the asset. This work demonstrator has reached TRL6.
- Automated inspection of S&C: Work was concentrated on the use of drones for S&C inspection. Developments have focused on the use of photogrammetry as a tool to utilise drone footage of S&C units to carry out detailed inspections that are visual and currently

involve heavy reliance upon manual inspection techniques. Algorithms have been developed to carry out dimensional checks of S&C units from drone footage, along with AI through machine learning techniques for confirming both the presence of components and also changes in component condition. This technology has been validated in an operational environment and has reached TRL5.

- Ultrasonic array inspection of cast high manganese steel railway crossings: the improvement in technology development in probe equipment for this work has shown a greater performance of equipment to carry out crack and defect inspection of cast crossings. Development work carried out during the project has demonstrated the technology has reached TRL4.
- Automated Repair of S&C; This work has built upon the developments of the Discrete Defect Repair system. The Crossing Repair Machine (CRM) has been designed and fabricated to a prototype stage after extensive design work to understand the machine requirements for crossing repair including profile measurement and reinstatement. Prior to fabrication, factory acceptance testing work was carried out to ensure the design meets the crossing repair requirements. The technology development has reached the target TRL 4.
- Advanced control integration into next generation S&C system demonstrator: A prototype of fault tolerant Actuation, Locking and Detection system has been developed and delivered. The switch control system (SCS) architecture has been designed to incorporate feedback loops and redundancy configurations for a CPU (Central Processor Unit) and actuator boards within the whole SCS system. This will enable the ALD system to operate in a degraded mode of operation, improving the availability of the S&C and reducing service affecting failures. The work has reached the target maturity of TRL4/5.
- Whole system design of next generation S&C concept: Comparative analysis of a wide range of competing and/or complementary concepts and technologies has been completed during this work. The key outcomes include key design features of a new S&C concept for modelling and assessment and whole life costing methodology for novel concepts.
- Next generation crossing development: This work has generated and validated a development model to assess the characteristics required to optimise the profile of a common crossing to minimise the forces generated in a crossing structure as trains transition across the wing rail to crossing nose interface. An S&C design tool that allows the automatic generation of required rail data (2D cross section) for simulation has been developed that will allow generation of variation in the running surface of the crossing nose and wing rail (TRL 4/5).
- Low noise & vibration tramway crossing demonstrator: A design feasibility study has been completed which has developed a solution removing crossings and providing continuous driving edges. A concentric moveable crossing design has been developed so that it can be passed in all directions of travel. The moveable tramway crossing has been taken from a basic design concept and has been developed into a virtual proof-of-concept at TRL 3. A 3D model of the crossing and a range of variants to address different conditions have been developed.
- Next Generation S&C Transition Zones: This work completed the development of a complex numerical simulation tool to analyse the long-term degradation of railway track in transition areas. A dynamic model and finite element settlement model were developed and validated as part of this work. This work has achieved TRL3 (experimental proof of concept).
- Application of Asphalt Track for Optimised S&C Support: The objective of this work was to assess and evaluate the additional performance that could be achieved from installing a layer of asphalt under S&C where non optimal ground conditions are present. The modelling has shown how the asphalt layer can successfully mitigate the effect of differential settlement along the switch panel and highlighted the necessity of further studies to optimise the layer thickness. This work has progressed the maturity of the technology to TRL 5.

TD3.2 Next Generation Switches & Crossings									
2015	2016	2017	2018	2019	2020	2021	2022	2023	...
Finished: In2Rail, S-Code				Ongoing: IN2TRACK 2, IN2TRACK 3					

In 2021, 2 deliverables were planned and also released. TD 3.2 has reported having accomplished 90% of the planned work up to the end of 2021, which represents 65% of the overall TD.

TD3.3 Optimised Track System

The TD challenges track construction assumptions, currently implicit in track design, and explore how innovative solutions in the form of products, processes and procedures can provide enhanced reliability, availability, sustainability, fewer capacity consumptions together with LCC savings. The aim is to derive medium-term solutions thus requiring harmonisation with current solutions and regulations. The TD also pays attention to the wheel/rail interaction that needs to work properly for a good performance of the entire railway system. The environmental aspect is also involved in his TD.

TD Progress

TD 3.3 builds on the project's activities of IN2RAIL, IN2TRACK (past projects), IN2TRACK-2 and IN2TRACK-3.

New bainitic rail solution for higher performance is under field validation and the current monitoring shows good results of the rail in terms of the resistance of rolling contact fatigue. This higher performance is due to improved material structure in the rail that is less crack prone, which will lead to less track maintenance activities as machining of rails, which will extend the life of the rail, contributing to LCC improvement and a higher availability of the track for operation.

The novel rail concept with replaceable rail head has been in service for about one year and exposed to more than 13 MgT with trains that have 31 tons axle loads. The preliminary results show promising results due to the general concept as well as withstand rolling contact fatigue.

A new concept of rail grinding combining conventional whetstone grinding with oscillating grinding has been developed and tested to fit into the demanding environment and requirements that are prescribed in the urban network. The test in real condition in a tramway network during 2021 shows promising results. Next steps are to make different tests in different conditions and follow the impact of noise after re-profiling.

Investigations have also demonstrated that the European standard for rail machining can be improved to some extent for some of the key operational parameters of machining rails.

Progress has been made in improving the knowledge of the wheel/rail system conditions in terms of how the wheel profile will affect the stability on track for high speeds vehicles. A new parameter named GIP for the wheel/rail system that enables the qualification of the stability on track at high speed has been developed and is described in the technical report for EN15302. New knowledge has been acquired as to how the system of wheel and rail is linked to vehicle stability and maintenance of rails. In addition, a test has been performed on how to quantify optically the rail friction.

The 3MB innovative slab-track solution has been manufactured and transported to the field for installation. This track test includes track section of 50 m and two embedded transition zones of each 14 m. This system will be instrumented and installed during 2022 in the harsh climate of northern Sweden exposed to 31 tons of axle load.

TD3.3 Optimised Track System									
2015	2016	2017	2018	2019	2020	2021	2022	2023	...
Finished: In2Rail, IN2TRACK				Ongoing: IN2TRACK 2, IN2TRACK 3					

In 2021, 2 deliverables were planned out of which 2 have been released. TD 3.3 has reported having accomplished 90% of the planned work up to the end of 2021, which represents 65% of the overall TD.

TD3.4 Next Generation Track System

TD 3.4 aims at providing solutions that improve the plain line track system substantially, targeting a time horizon of around forty years beyond the current state-of-the art. The improvements are planned for delivery through the development of novel sub-systems and components, combined with more efficient and targeted inspection and maintenance processes. Step-change solutions are prioritised over short-term incremental improvements and as such, a longer-term implementation timescale is envisaged for the majority of technologies developed.

TD Progress

TD 3.4 builds on the project's activities of IN2RAIL and IN2TRACK (past projects), IN2TRACK-2, IN2TRACK-3 and IN2ZONE.

Next generation track system, sub-systems and components:

- Next generation track system:
 - Next generation plain line track systems have been evaluated, building on the high-level functional requirements defined earlier in IN2TRACK2. Material and component improvements were identified, which could be applied more widely.
 - Development of a next generation track transition zone has commenced, to offer a step-change reduction in maintenance requirements, compared to existing solutions. Three potential designs of self-levelling sleeper have been identified for development and outline proposals for resilience-based monitoring progressed.
 - A design for noise shielding close to the rail has been tested in a laboratory, with the aim of reducing airborne noise, without adversely affecting the ability to inspect and maintain the track. The experimental results suggest that the absorptive treatment can result in a reduction of 4-5 dB in rail noise, with an overall noise reduction of 2-3 dB.
 - Embedded sensors for condition monitoring of plain line track have been identified and proposals made for developing these key concepts.
 - A novel drainage solution for next generation track has been developed to proof-of-concept. This has shown that water can be moved from the subgrade to the cess area and from there by capillary action and transpiration/evaporation.
- Full-scale virtual demonstration of next generation track system:
 - Three-dimensional models of vehicle and slab track have been developed, to allow slab track design optimisation.
 - Advanced numerical modelling of the train-track-ground system has been developed, to analyse the performance of a transition zone between slab track over an embankment and in a tunnel. In 2022/2023, it is the intention to apply the model and methodology developed to the design and analysis of the long-term behaviour of transition zones.
- Track Digital Twin:
 - A Building Information Modelling (BIM) demonstrator has been created for a representative section of a plain line track. Further development is scheduled with the addition of a new RCF (Rolling Contact Fatigue) module for predictive maintenance.

- A framework for forecasting the performance of railway track assets over time was developed and applied in a case study. The next steps include considering the maintenance and renewal actions in the framework to understand their influence on the performance of the asset, to contribute to optimised track system management.
- Innovative slab track solutions:
 - High-level design of two new slab track concepts (Z-Track and H-Track) was carried out, together with laboratory testing of a novel technique to allow ease of dismantling, in the event of the requirement for localised repair or replacement.
- Rail for next generation track:
 - The performance of 60E2 profile bainitic rail installed in plain line track has been monitored during the first year in operation. The monitoring of rails, welds and weld heat affected zones, started just after rail installation and initial grinding. From inspection of the test sites, the overall behaviour of the bainitic rail against head checks appears favourable, in comparison with the behaviour of R260 and R350HT installed at the same location.
- Smart geogrids and geotextiles:
 - Preliminary Discrete Element Method (DEM) simulations and one-dimensional compression tests were carried out on fibre reinforced ballast materials, with the aim of identifying key parameters to optimize the characteristics of fibres to be used for ballast reinforcement (length, width, percentage, etc.). However, the experimental results suggest that adding fibres to the ballast does not lead to a reinforced resistance to compression.

Track inspection, monitoring and maintenance:

- Automated inspection and repair:
 - Proof of concept of autonomous ultrasonic rail inspection was demonstrated, using mature ultrasonic technology to identify artificial rail head defects using an autonomous unmanned vehicle. Further work is planned in 2022/23 with the aim of developing a prototype for demonstration within a relevant track environment. This work is being carried out in collaboration with TD 3.8.
 - A review was carried out, to identify the requirements for an automated system for the localised repair of isolated track geometry defects, with the potential for autonomous operation.
- Rail defect monitoring:
 - A contactless ultrasonic method of identifying rail head defects of less than 5mm depth using electro-magnetic acoustic transducers (EMAT) has been demonstrated in real field conditions at TRL5. This system will be further developed to enable field track testing of an enhanced prototype.
 - Investigation has been carried out into the use of thermography for detecting rail foot defects. This work was developed to TRL3, proof of principle, through modelling and laboratory tests, which suggest that thermal disruptions are present in the areas surrounding a defect.
- Thermal rail stress measurement:
 - An ultrasonic method of non-destructive measurement of thermal rail stress was developed. This concept was proven in the laboratory and initial results from full rail section tests are promising.
- Cold spray additive manufacturing repair of rails:
 - Laboratory testing of a method of rail repair using cold spray additive manufacturing has been carried out. This has proved the feasibility of this technique for application in railways and the work is planned for continuation with the aim of providing a physical demonstration of the process.

TD3.4 Next Generation Track System									
2015	2016	2017	2018	2019	2020	2021	2022	2023	...
Finished: In2Rail			Ongoing: IN2TRACK 2, IN2TRACK 3, IN2Zone						

In 2021, four deliverables were planned and submitted. TD 3.4 has reported having accomplished 90% of the planned work up to the end of 2021, which represents the completion of 50% of the overall TD.

TD3.5 Proactive Bridge and Tunnel Assessment, Repair and Upgrade Demonstrator

The main objective of the TD is to improve inspection methods and repair techniques in view of reducing costs, improving quality and extending the service life of existing structures. One of the main objectives also consists of reducing the cost for new bridges regarding bridge dynamics. Reduction of noise and vibrations are also among the prioritised objectives.

TD Progress

TD 3.5 builds on the project's activities of IN2RAIL, IN2TRACK (past projects), ASSETS4RAIL, IN2TRACK-2 and IN2TRACK-3.

Despite some postponed site installations due to the Covid-19 pandemic, significant results have been found and demonstrations performed during 2021:

First prototypes for inspections robots of drainage pipes have been validated in relevant environments. Prototype robots are able to move in pipes, pass obstacles, and be produced at relatively low cost. The robots will enable cost reductions for inspection and savings on cost for maintenance by 25% by prescriptive maintenance and at the same time reduce the risk of unplanned stops due to the infrastructure issues.

First generation of technology to clean long drainage pipes has been successfully demonstrated in operational environments. Tunnels over 1 km in length are able to be cleaned from deposits under full operations. The solution enables the reduction of long-term costs for functioning drainage pipes by 25%.

First generation of rapid tunnel lining patch repair has been demonstrated in relevant tunnel environments. The new solution includes semi-automatic work form, fast setting grout and preparation for robot platform mounting. The fully developed technology reduces patch repair time by 50 %.

The development technology for measurements of noise emissions has been successfully demonstrated in operational environments and used for the basis in the design of noise dampers. Furthermore, noise dampers have been successfully demonstrated and actual system proven in operational environment. Noise generated from passing trains is typically emitted from bridge elements. Sound emission from metallic bridges can be reduced by 5dB in significant frequencies.

The first generation of bridge fatigue assessments have been demonstrated in operational environments. Refined models are calibrated by full-scale tests, combined with real data on loads to reduce. Uncertainties are reduced or eliminated, leading to extension of up to four times of the remaining service life whilst maintaining proven safety.

A solution for structural improvement of existing conventional bridges to be able to carry high-speed trains has been demonstrated without disturbing traffic and proven to work in operational environments. Tailored passive dampers have been installed. Forced vibration tests, as well as monitoring of real train passages, validate the new solutions allowing for line speed upgrades without replacing existing bridges. This allows for very high monetary and environmental savings.

TD3.5 Proactive Bridge and Tunnel Assessment, Repair and Upgrade									
2015	2016	2017	2018	2019	2020	2021	2022	2023	...
Finished: In2Rail, IN2TRACK, Assets4Rail						Ongoing: IN2TRACK 2, IN2TRACK 3			

In 2021, 10 deliverables were planned, out of which 10 were released. TD 3.5 has reported having accomplished 90% of the work planned for 2021, which represents 70% of the overall TD 3.5.

TD3.6: Dynamic Railway Information Management System (DRIMS) Demonstrator

The TD defines an innovative system for the management, processing and analysis of railway infrastructure data obtained from TD 3.7 (Railway Integrated Measuring and Monitoring System - RIMMS Demonstrator). The aim is to provide high-quality input to TD 3.8 Intelligent Asset Management Strategies (IAMS). The main goal of these three TDs is to create new and optimised strategies, frameworks, processes and methodologies, tools, products and systems for the implementation of a step change in risk-based, prescriptive and holistic asset management in the rail sector.

TD Progress

TD 3.6 builds on the project’s activities of IN2RAIL, IN2SMART and IN2DREAMS (past projects), IN2SMART-2 and DAYDREAMS.

Work on the development of data analytics tools has progressed accordingly to schedule; the mitigation activities implemented during 2020 (mainly the collection and study of historical data) allowed for the design and development of data analytics algorithms that, with the new availability of data, can be tested and validated with first results and prototypes being operational.

The main developments regarding TD3.6 are the following:

- Big Data platform deployment: system architecture is now operational for most of the TD 3.6. - 8 use cases (e.g. the Decision Support System and analytics framework and the IT architecture has been tested and deployed by the IM for the use case on the Italian Urban Metro System IAMS).
- Implementation of data collection, cleaning and storage is implemented for most of the Big Data platform (e.g in the data collection for track and bridges started in the UC for Integrated Assets Management for Civils). These live data are now used to test and validate the models implemented using historical data.
- First results of analytics models and algorithms developed in 2020 have now been validated with the real data in order to fine-tune them for the operational environment. A set of analytics modelling approaches has been implemented (e.g. decision forest, DBSCAN) and optimized by adding new data sources, such as weather data, in the analysis and increasing the acquisition frequency of data in various assets (e.g.: track circuits, switch&crossing, bridges, track).
- Design and development of the first HMIs have begun. Early results are available and have been validated with the final users (e.g. first 2 interfaces for wheels and track circuits monitoring).

In addition, the TD achieved the following tasks:

- Extract relevant maintenance infrastructure-related information from measurement data by the development of smart data processing methods for decision supports of maintenance activities. This includes the development of an Algorithm for sensor system to support track geometry monitoring, an Algorithm for wayside computer vision system, an Algorithm for data collection system and a Methodology for maintenance decision support and impact assessment of condition monitoring.
- Appropriate storage and management of generated data/information, considering big data solutions and standardized interface, to allow further data mining and transmission of data to other management systems. This includes Data handling solutions for sensor system to support track geometry monitoring, Data handling solutions for wayside computer vision system and Data handling solutions for data collection system.
- First demonstrators of HMI have been developed and they include functionalities of anomaly detection, fault prediction and decision support.

TD3.6 Dynamic Railway Information Management System (DRIMS)									
2015	2016	2017	2018	2019	2020	2021	2022	2023	...
		Finished: IN2SMART, IN2DREAMS				Ongoing: IN2SMART 2, DAYDREAMS			

In 2021, 26 deliverables were planned, out of which 18 were released. TD 3.6 has reported having accomplished 80% of the planned work up to the end of 2021, which represents 70% of the overall TD 3.6.

TD3.7: Railway Integrated Measuring and Monitoring System (RIMMS) Demonstrator

The TD aims at providing innovative tools and techniques to capture information on the current status of infrastructure assets in a non-intrusive and fully integrated manner. To this end, the TD focuses on infrastructure asset status data collection in close interaction with TD 3.1 Enhanced Switch & Crossing System Demonstrator and TD 3.5 Proactive Bridge and Tunnel Assessment, Repair and Upgrade Demonstrator.

TD Progress

TD 3.7 builds on the project’s activities of IN2RAIL and IN2SMART (past projects), IN2SMART-2 and ASSETS4RAIL.

During 2021, all the in-field installation and the functional test of the devices have been performed and validated by the respective IMs. Data collection and cleaning activities have built upon last year’s progress and are now in place in the majority of use cases. This has paved the way for the analysis of the data collected and the design and implementation of the first algorithms by TD 3.6 related activities.

Examples of achievements are the following:

- Within the scope of the “Italian Urban Metro System IAMS: design and deployment” Use Case, a smart solution entirely based on optical fiber technology and fiber optic sensors that combines the Weigh-in-Motion (WIM) functionality with the Wheel Impact Load Detector (WILD) has been successively deployed and the data collection demonstrated (19 fiber sensors are mounted to the rail foot, between two sleepers, and are capable of detecting the vertical forces generated by the single wheel/rail contact, in order to measure both quasi-static and

dynamic solicitations imposed to the rail). The information collected is stored in the IAMS architecture in cloud, in order to feed the algorithms for anomaly detection and the DSS interfaces (TD 3.6 and TD 3.8)

- Within the scope of “Anomaly detection for rail fastener systems” Use Case, a Lindometer was installed and successively tested in the operational environment on in-service train. Online data transmission and collect data for the development of anomaly categorisation algorithm (TD 3.6), demonstrating promising results to monitor rail fasteners.

In addition, the following objectives have been achieved:

- The prototype of train-borne sensor system to support track geometry monitoring has been demonstrated and validated on a track geometry inspection coach running at up to 100 km/h in Italy (at TRL 5). The developed sensor system is able to track the lateral movement of the wheels on the rails. It can be combined with the accelerometers to monitor the lateral and vertical track geometry parameters on the in-service vehicles. This will reduce the investment costs for track geometry measurement and increase the data availability, which finally increases the track reliability and availability.
- The prototype of the wayside computer vision system for monitoring rolling stock has been demonstrated and validated in a shunting yard in Germany (at TRL 6). The prototype autonomously inspects the pass-by freight wagons. The algorithm can automatically identify and isolate the critical components in the video frames for further fault detection. This can reduce human intervention, save maintenance costs, and improve rolling stock and track reliability.
- The prototype of the data acquisition system has been implemented and validated on an in-service point machine in Lithuania (at TRL 6). This prototype autonomously collects the key parameters of the drive motor and the heating system within the point machine. The module design allows an extension of the connected sensors and the adaptation to other railway signalling field elements. The acquired data is forwarded to the cloud SCADA system for data handling, where the developed algorithms are applied for fault diagnosis.

TD3.7 Railway Integrated Measuring and Monitoring System (RIMMS)									
2015	2016	2017	2018	2019	2020	2021	2022	2023	...
Finished: In2Rail, IN2SMART, MOMIT, Assets4Rail						Ongoing: IN2SMART 2			

In 2021, 31 deliverables were planned, out of which 23 were released. TD 3.7 has reported having accomplished 80% of the planned work up to the end of 2021, which represents 70% of the overall TD 3.7.

TD3.8: Intelligent Asset Management Strategies (IAMS)

The vision of the TD is a holistic, whole-system approach of asset management employing collected and processed infrastructure data provided by TD 3.7 Railway Integrated Measuring and Monitoring System (RIMMS) Demonstrator and TD 3.6 Dynamic Railway Information Management System (DRIMS) Demonstrator. This includes translating long-term strategies into day-to-day execution of the maintenance and other short term maintenance activities. It also includes new and advanced working methods, tools and equipment and logistics solutions, supporting the LEAN execution of intelligent maintenance processes.

TD Progress

TD3.8 builds on the project's activities of IN2RAIL and IN2SMART (past projects), IN2SMART-2 and STREAM.

In the decision-making use cases first prototypes and system set-up are being developed. For example, a specific isolated service to plan tamping activities allowing to quantify possessions, resources, costs and priority. This is the basis for more complex possession planning taking other activities into account. For strategic planning: a visualisation overview has been established and the focus is now to determine opportunities for better capacity distribution.

With regard to the LEAN execution work in 2021: Based on the analysis of the tests on a mobile system of a Water Jet Cutter, conclusions pointed that this solution is not a good example to demonstrate the robot capabilities of an end effector (there is a doubt whether it is a good alternative for grinding). Consequently, two alternatives to the Water Jet Cutter as end effector were reviewed, and the choice was made for end-effector that can screw and unscrew the bolts of rail fasteners automatically and it can move the clips with a magnetic system. It includes a self-learning principle: it detects the repetition pattern and will increase the speed. The first test has been undertaken and will be analysed in 2022.

Additionally, the following achievements have been reached in 2021:

- Development of a suitable platform capable of data gathering supporting the understanding required to develop larger and more complicated vehicles. The process of developing the concept from a small lab-based model to a larger vehicle, capable of operating on realistic environment infrastructure, as the basis for future vehicles.
- Implementation of the On-Track Autonomous Multipurpose Mobile Manipulator (OTA3M) system, that includes hardware design, sensors and software to develop autonomy and perception capabilities compatible with any rail-road excavator.
- Design and development of the first version of the MMPE, an exoskeleton to be worn by railway workers who handle heavy tasks to minimize their muscular fatigue. The device is compliant with safety requirements accordingly with the Machinery Directive.

TD3.8 Intelligent Asset Management Strategies (IAMS)									
2015	2016	2017	2018	2019	2020	2021	2022	2023	...
Finished: In2Rail, IN2SMART					Ongoing: IN2SMART 2, STREAM				

In 2021, 28 deliverables were planned, out of which 20 were released. TD 3.8 has reported having accomplished 75% of the planned work up to the end of 2021, which represents 70% of the overall TD 3.8.

TD3.9: Smart Power Supply Demonstrator

The global objective of the TD is to develop a railway power grid in an overall interconnected and communicating system. This will enable improvements and optimizations regarding train traffic capacity, energy losses and costs, energy supply security and availability for the railway system and environmental impact.

TD Progress

In 2021, the TD 3.9 builds on the progress made by IN2STEMPO to finalize the demonstrators defined in In2Rail, and FUNDRES.

The smart control and protection demonstrator has been further implemented by testing on several layers. The demonstrator will upgrade the station control systems within 16,7 Hz railway networks, introducing IEC 61850 and process bus. Especially process bus is a new communication network type, installed between IED (e.g. protection devices) and Merging Units (measuring devices for voltage and current). Process bus reduces the wiring effort significantly and enables new protection concepts. In the upcoming last project period, the demonstrator will be applied to trial operation in an actual switch gear station to achieve TRL 5.

The FACTS demonstrator conducted several simulation models, including extensive real-time simulations, and has been further applied to investigate the technology under realistic operational conditions. Based on the first results, an application guideline has been created to support operators with the choice and specification of a FACTS solution in their system. Additionally, general certification requirements for FACTS have been defined to ease the product market introduction.

The TD investigated a new DC power supply system with an increase of nominal voltage to 9kV. The developed solution will enable higher capacities and high-speed operation in existing DC networks. As a result of these studies the system achieves the same capacity as the standard AC systems with 25 kV/50 Hz using the benefits from DC-traction. The concept of a Solid-State-Transformer based on Multilevel-Inverters, usable for integration in the DC power supply has been developed. The result of the use case “reinforcement of 1,5 kV DC-System by 9kV feed wire” demonstrated an efficiency increase of 5% (A complete change to 9kV increases the efficiency of traction power supply by 10%).

TD3.9 Smart Power Supply										
2015	2016	2017	2018	2019	2020	2021	2022	2023	...	
			Finished: In2Rail, FUNDRES							
			Ongoing: IN2STEMPO							

In 2021, 5 deliverables were planned out of which 4 were released. TD 3.9 has reported having accomplished 90% of the planned work up to the end of 2021, which represents 80% of the overall TD.

TD3.10: Smart Metering for Railway Distributed Energy Resource Management System Demonstrator

The objective of the TD is to achieve a fine mapping of energy flows within the entire railway system, as a basis of any energy management strategy.

TD Progress

TD 3.10 builds on the project’s activities of IN2RAIL and IN2DREAMS (past projects), and IN2STEMPO. In 2021, the work has been carried out on all three use cases of the Smart Metering concept as defined in the MAAP:

- Use case 1: Commercially Operated line (CO-OP) Use Case on a line in commercial operation south of London.
- Use case 2: Stationing and Maintenance facilities operation (STM-OP) Use Case in the Saragossa tramway depot.

- Use case 3: Electrical Infrastructure monitoring (IN-OP) Use Case on the London North Westcoast mainline.

In the CO-OP Use Case the robustness improvement performed last year, in terms of data acquisition and transmission to the cloud, has now enabled gathering of reliable data. However, an issue that is still under investigation occurred recently on one of the three sites fitted with Smart Metering systems: Chiddingstone substation. Databases and dashboards developed earlier have been replicated within other ODM (Operational Data Management), to be able to visualise recorded data from the beginning of meters implementation. Several user applications have been initiated, based on the dashboards, in particular: assessment of spare capacity on the line, and assessment of traction power system losses.

In the STM-OP Use Case, new sensors have been installed in the Saragossa tram depot to measure the mechanical tension of the catenary and switches state. In the end, a large variety of measurements is available: 750V traction substations, 400V auxiliaries, environment values such temperature and wind velocity, and mechanical data of the infrastructure. A preliminary user application has been developed, to monitor data and visualise energy sharing between consumers. The temporary data storage done in local servers has been transferred to IN2STEMPO ODM.

In the IN-OP Use Case, the first set of equipment was installed in January 2021 in Acton Lane feeder station, then Camden sectioning cabin and Bushey feeder station were instrumented. All three sites are operational and data are generated (although a communication issue needs to be fixed in Acton Lane). A preliminary dashboard has been developed to monitor electrical values from the railway power system. Trigger tests have also been performed in order to reduce the amount of data to be transmitted to the ODM. This will enable the transmission of high frequency voltages and current acquisitions, for a limited period of time, only when a special event is detected.

In this use case, the transmission system has also been designed and configured to send data through two different streams. The first stream sends data flow to the ODM, used for all 3 use cases. The second stream sends data to another data platform, part of the ITD Enhanced Energy, thus linking TD 3.10 to TD 3.9. This will demonstrate that Smart Metering is an open system, able to connect to several platforms for different usage.

TD3.10 Smart Metering for Railway Distributed Energy Resource Management System									
2015	2016	2017	2018	2019	2020	2021	2022	2023	...
Finished: In2Rail, IN2DREAMS				Ongoing: IN2STEMPO					

In 2021, two deliverables were planned, out of which two were released. TD 3.10 has reported having accomplished 90% of the planned work up to the end of 2021, which represents 80% of the overall TD.

TD3.11: Future Stations

The primary objective of the TD is an improved customer experience at stations increasing thus the number of customers that will use rail as their preferred transport mode. The TD is organised around four identified key functional demands; two demands relate to improving capacity, safety and security in large stations, one demand relates to the design of small stations with the objective of reducing whole life costs and standardising design where possible and the final demand relates to platform to train accessibility.

TD Progress

TD 3.11 builds on the project's activities of FAIRSTATIONS (past project), and IN2STEMPO.

With regard to crowd management, the implementation of components to run two planned scenarios was concluded positively in Warsaw East Station in 2021:

- Training Scenario: Station operators will be put in an immersive environment and will have to react to specific situations in the station. The activities consisted of the creation of a simulated Control Center environment close to the real environment. Trainer and trainees’ interactions with simulation and 3D models have been integrated.
- Forecast scenario: Simulated and predicted situations will be proposed to station operators based on Video Content Analysis – VCA. Calibration algorithms have been developed to adjust simulation to VCA results, the goal is to offer a simulation that is as close as possible to the real situations.

As for “standardization and prototypes for small stations”, the technical specifications to be implemented for the construction work in 2022 have been issued to perform at a later stage the evaluation of their functionalities and effects using the railway station Jurata in Poland. This includes:

- Specifications with a full thematic approach to existing situations with Catalogue.
- Improvement of small stations in terms of materials, components, life cycle costs, energy impact.
- Improvement of small stations regarding smart solutions, digitalization, ticketing technologies.

TD3.11 Future Stations									
2015	2016	2017	2018	2019	2020	2021	2022	2023	...
			Finished: FAIR STATIONS		Ongoing: IN2STEMPO				

In 2021, five deliverables were planned, out of which four were released. TD 3.11 has reported having accomplished 85% of the planned work up to the end of 2021, which represents 80% of the overall TD.

1.4.4. IP4 IT Solutions for Attractive Railways Services

In order to become more attractive, rail must respond to customer needs to support seamless door-to-door multimodal journeys encompassing different modes of transport. Rail must achieve interoperability with other transport modes and mobility services, within different regions, cities and across borders. In view of this objective, rail needs to take due advantage of the ever-growing connectivity of people and objects, the availability of European Global Navigation Satellite System (GNSS) based location and other means of localisation, the advances in cloud computing, Open Data and Big Data Analytics and the wide dissemination of Internet and social media. Multimodal integration will also take benefit from existing rail standards as FSM and TAP TSI.

The picture below represents the areas where IP4 Technological Demonstrators will introduce improvements.



To achieve this, the IP4 ecosystem aims to integrate and make interoperable all possible transport modes and travel services: rail, urban transport (metro, tram, and buses), airlines, private cars (such as the use of toll roads and parking, which have an associated price) and also shared modes (cars and bikes). Thus, multimodality and the use of public transport are being fostered, making it easier for travellers to connect with rail stations and airports, regardless of where and how they start their journey. For the future, Demand Responsive Transport and Ride Sharing will be included in the ecosystem to ease the access to everyone to long distance trips, even to those living in not well-connected areas.

IP4 Ecosystem has also evolved to implement at European Level the new Mobility-as-a-Service (MaaS) paradigm, which considers the mobility system as a whole in order to achieve an optimal and sustainable transport scheme. This way, the IP4 ecosystems facilitates the task to create formal contracts that could involve the agreements, business rules and financial compensation that shall occur between the different stakeholders when combining their services into a joint product. In the future, this component will evolve to be used also to create MaaS Packages that integrate a variety of transport services that could include multiple Transport Service Providers.

IP4 is organised around 7 Technological Demonstrators within three priority research and innovation areas as shown in the graph below.

- Technical Framework: Interoperability Framework and Business Analytics
- Multimodal Travel Services: Travel Shopping and Booking and Ticketing
- Customer Experience Applications: Travel Companion and Trip Tracker

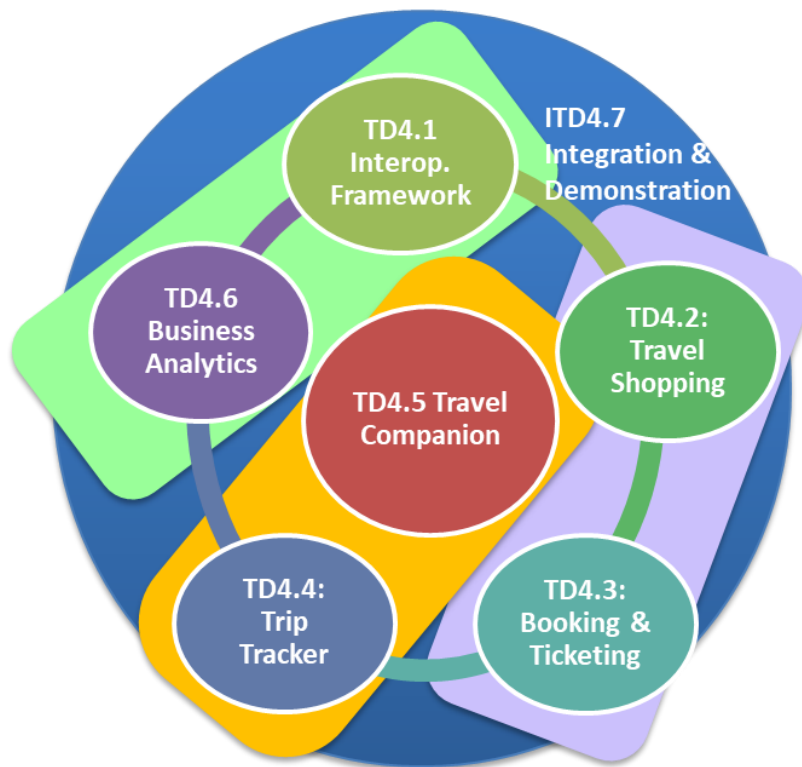

IP4 projects are contributing to developing innovations in each TD. All the outcomes of IP4 project will contribute to one single Integrated Technological Demonstrator (iTD4.7), which will merge all the developments.

TD 4.1 Interoperability Framework

The TD aims to facilitate multimodal travel in a highly diverse environment and with many transport modes. Interoperability at the semantic level defines formal and explicit models of the transportation domain in an open, standard, machine-readable language that is exchanged automatically by computers, therefore allowing seamless access to all transport data and services in a multimodal and distributed environment. Hence, TD 4.1 is a key technology enabler for a complete transformation of the European transportation ecosystem.

TD Progress

The TD covers different aspects of the Interoperability Framework, including the definition of architectural principles, the implementation of components with basic capabilities and the development of a reference ontology.

By 2021, the efforts have been divided into A-REL and F-REL of the Interoperability Framework, second and final releases of the IF. The CONNECTIVE project has finished the implementation of the A-REL Interoperability Framework (IF) based on the conclusions of the internal analysis carried out during the C-REL, the A-REL takes into account the requirements and issues that have been seen during Co-Active

and ATTRACKTIVE. The issues found in the C-REL version of the IF and its improvement with the A-REL are reported in CONNECTIVE D1.2 – Architectural Principles and Design A-REL. After initial tests, the A-REL has demonstrated higher performance and scalability compared to C-REL and it includes DRT integration, Group availability and Trip Tracking services that enlarge the functionalities provided to the users.

The A-REL has been part of the second complete integration of the IP4 ecosystem as part of the BETA RELEASE (2021) of COHESIVE. The projects that contributed to the Beta release were CONNECTIVE and SPRINT, which developed solutions to improve the registration of services and the performance. Thanks to the IF, the integration was possible of the different TSPs that were part of Shift2MaaS into the IP4 ecosystem and the connection with the software developed by MaaSive, which was crucial to demonstrate end-to-end functionalities for shopping, booking, ticketing and trip tracking.

In addition, during the initial months of 2021, the services provided by the Shift2MaaS TSPs have been integrated to the Interoperability Framework and have been tested in the Shift2MaaS pilots (Malaga, Lisbon and Central East Corridor). The integrated solution included seven TSPs that provided Shopping, Booking and Issuing services with 50 users per pilot. Further, the functionalities and services provided by MaaSive F-REL have been integrated to the Interoperability Framework to become part of COHESIVE Beta Release, demonstrated at S2R Innovation Days 2021 and tested in Ride2Rail and IP4MaaS pilots that will be carried out in 2022.

In terms of ontologies, the CONNECTIVE project has been working on the development of different modules of the modular ontology divided into subgroups that cover different aspects:

- The Infrastructure Static Data Module is based on Transmodel (Core, Commons, Journey and facilities).
- The Tariff module is based on Transmodel (Fare components, Controllable elements, Fare product, Sales and Ticketing equipment).
- The Online Distribution sub-module Online Distribution of OSDM (based on FSM) covers the communication to manage the sales process of transport offers.

In the last months of 2021, the CONNECTIVE project started the Specification and initial implementation of the F-REL Interoperability Framework (IF) based on the conclusions of the internal analysis carried out during the A-REL. The F-REL takes into account the requirements and issues that have been seen during MaaSive and the preparation of the Shift2MaaS pilots. These issues, encountered during the A-REL, are the following:

- TSP services analysis: limited documentation and in some cases no documentation at all.
- Mapping the services between TSP and IP4: long and difficult process to map services and fields between the TSP and the IP4 IF.
- Insert stop places into the RDF Repository: manual process to convert GTFS file into triplets and insert them into the RDF repository. This action can take up to 2 hours to be completed (recently this step has been deprecated).
- Development of the service implementation providers: manual development of Java classes to establish communication between TSP web servers and IF.
- Translation request/response between TSP and IP4 services: manual development of the SPARQL query. Impossibility to debug the query (recently this step has been deprecated).

Development Service Implementation Orchestrators: creating a new orchestrator of a new service. The object required of the interchange of information is tedious and long to create. There is not an official protocol if any modifications in the request/response are required.

The first draft of the IF ontology was built on the IT2Rail project. Its evolution is reflected during subsequent projects as a wide range of needs were imposed by the S2R-IP4. These needs made it tedious for all the operations and processes to fit into a single ontology. Therefore, the need arose to define new multiple ontological models that allow the IF to respond to the flows and operations that cover the traveller's journey (shopping, booking, issuing, trip tracking, etc.) based on transport standards.

Moreover, the F-REL Architecture of the IF has been designed to consume fewer resources during the operation, improve the service integration procedure and become more configurable.

TD4.1 Interoperability Framework									
2015	2016	2017	2018	2019	2020	2021	2022	2023	...
Finished: IT2RAIL, GOF4R, ST4RT, SPRINT						Ongoing: CONNECTIVE, RIDE2RAIL			

During 2021, 2 deliverables were planned out of which 2 were released. The results of the deliverables produced this year finalised the implementation of Additional Release and its closure, which is the 2nd release of the 3rd proposed for the programme. The other two represent the architecture and description of the components of the F-REL.

Since the beginning, TD4.1 has accomplished 95% of the planned work up to the end of 2021, which represents approximately 90% of the overall TD objectives.

TD 4.2 Travel Shopping

The concept of TD 4.2 Travel Shopping is both to enable and to respond to an emerging single European multimodal transport marketplace within a Single European Transport Area (SETA). The IP4 approach will promote the integration of distributed travel operators' data and services and the orchestration of services such as expert journey planning and offer building for all modes. It will benefit from the Interoperability Framework that enables applications based upon different interfaces, standards, or coding lists, to communicate meaningfully but without costly application adaptations with the existing legacy systems of all stakeholders. The TD4.2 contribution to IP4 System is to enhance the technical facilitation of a one-stop-shop capability, to enable comprehensive choice of itineraries and offers from modes/operators capable of responding to customer mobility requests, especially using existing services from all stakeholders by interfacing their legacy systems.

TD Progress

The basic idea of the travel shopping system was designed within IT2Rail (Lighthouse Project) using a distributed architecture. The support to this TD continued with the Co-Active project which enhanced this decentralized approach and continued throughout MaaSive, which ended in 2021, and continues with ExtenSive that started in December 2020, with piloting activities performed in Ride2Rail and IP4MaaS open call projects.

The main technical outcomes of TD4.2 Travel Shopping in 2021 are:

- Finalisation and testing of the planned Multi-User Capabilities (e.g. allowing users to travel in a group).

- Integration of Demand Responsive Transport to Travel Shopping. In order to ensure the successful implementation, we performed a number of test cases and consequently, fulfilled the two existing Use Cases.
- Successful test of a variety of Failure cases for Travel Shopping to check the proper functioning of the system.
- Final enhancements of the Meta Network Builder and Meta Network Explorer in order to create a stable Meta Network.
- Optimization of the Journey Planning process based on multiple criteria Pareto-Optimization.
- Included individual transport for the main part of the travel to improve intermodal travel solutions calculated within the Travel Shopping process.
- Included individual transport for the first and last mile of a journey and therefore enriching the existing router for individual transport (walk, bike, car).
- Provided a Travel Shopping Service within the Shift2Rail Ecosystem to a TSP.
- Manual inclusion of information from a TSP (fares and products) on the CMMP.
- Validation of registration of new users on the CMMP.
- Administrator able to check the record of actions on the CMMP.

During 2021, MaaSive supported the pilots performed by Shift2MaaS. Pilots in Malaga, Lisbon and Central East Corridor included seven TSPs that provided Shopping, Booking and Issuing services with 50 users per pilot.

Furthermore, close collaboration between the Open Calls (IP4MaaS and Ride2Rail) and ExtenSive started. The timelines of the projects were aligned in order to perform a large number of pilots in 2022 and 2023. In depth technical discussions are ongoing in order to support the Open Calls and enable them to pilot developed functionalities. In 2022, the TD will demonstrate functionalities finalised within MaaSive, pilots in 2023 will focus on new developments within ExtenSive.

TD4.2 Travel Shopping									
2015	2016	2017	2018	2019	2020	2021	2022	2023	...
Finished: IT2RAIL, Co-Active, MaaSive						Ongoing: ExtenSive, Ride2RAIL, IP4Maas			

During 2021, 6 deliverables were planned out of which 6 were released. They covered topics of Travel Shopping and Contractual Management.

Since the beginning, TD4.2 has accomplished 100% of the planned work up to the end 2021, which represent 90% of the overall TD.

TD 4.3 Booking & Ticketing

Today, even within a given mode of transport (air, rail, urban, etc.), the rights to travel have, in the best case, limited interoperability between the various travel service operators; and this interoperability is almost non-existent between the modes themselves. This TD aims to orchestrate multiple but parallel interactions with several booking, issuing, payment and ticketing engines, including the all-important roll-back activities. This will radically simplify the traveller’s life, by abolishing uncertainties and complexities associated with ‘behind-the-scenes’ multiple booking, issuing, payment and ticketing processes.

TD Progress

The efforts of previous projects (e.g. Co-Active) and the contributions of MaaSive and Extensive projects to this TD allowed to reach a second implementation and integration of all components with other IP4 TDs, which is demonstrated during the BETA RELEASE demonstration in 2021 with Travel Service Providers (TSP) covering different transport modes.

Activities in 2021 have progressed by enhancing the existing components, creating new ones and starting the integration of new modes of transport (such as transport on demand) and paradigms (such as MaaS). The work further focused on Specifications, the definition of Uses Cases and establishing the planned work to implement each of the functionalities.

In 2021, new use cases have been introduced such as Multi User Capabilities. In order to deliver such features, modifications in the orchestrators have been made. These updates are compatible with all pre-existing features so far developed involving the legacy system of the services tested in the pilots. All these software components contribute to the interoperability between the different TSP, orchestrating parallel interactions of different booking and ticketing engines seamlessly for the passenger.

Following current MaaS approaches, one of the objectives was to include, within the different flows of the IP4 ecosystem, the concept of Mobility Package as a kind of subscription or travel card that combines a number of transport products that could include different modes and operators. Thus, the possession of a Mobility Package by a user needs to be taken into account for example when calculating the price of the offer. By enabling the creation and consumption of these Mobility Packages, IP4 aims at changing traveller's behaviour towards more sustainable modes, offering better service and affordable mobility to reduce car ownership, but at the same time assuring the flexibility and convenience of a car.

The new Mobility Packages flow manages the lifecycle of Mobility Packages since its creation using the Contractual Management Marketplace (presented in TD4.2) and its purchase through the Travel Companion, to its use at shopping and travelling time. In 2021, the complete flow was implemented by developing the Mobility Package Engine that applies the Mobility Packages at shopping time in order to show the advantages of purchasing Mobility Packages, so the user can choose its best choice.

The Generator token toolkit for operators has been improved by developing a frontend that facilitates its usage. This Generator Token toolkit allows the configuration of new entitlements for existing TSPs and/or the configuration of an entitlement that could be adopted by different providers. At the moment the second implementation of this Generator Token toolkit for TSP using the S2R environment has been developed and will be provided as a SaaS component. This generic token toolkit consists of a Web Portal and a Configuration API that allows TSP to configure their own metadata (or use the generic metadata structure proposed) and embodiments. A metadata compiler will interpret the metadata, and feed token generation and validation modules in order to do the serialisation and deserialisation of the entitlement metadata.

Moreover, an implementation of a ticket inspection application has been accomplished, which allows new and simplified ways to inspect the tickets provided via the ecosystem and with the interaction to the traveller apps in close vicinity. The inspection app also enables the inspector to block the ticketing function of the traveller apps in close vicinity for the time of inspection in the vehicle as a fraud protection mechanism.

Another area of work aims at providing the ecosystem with Customer Relationship Management (CRM) capabilities to improve the management of user information and to allow managing customer

claims and passenger rights. A CRM has been developed with this aim, integrated with other existing components of IP4 such as the Cloud Wallet. The CRM allows TSP to manage users’ data, manage invoices and registration and manage claims that are associated with the Travel Companion Web Portal (TD4.5) and Passenger Rights components. Moreover, a new Best Price Orchestrator has been deployed that calculates the best offer to the user.

In 2021 the work focusing on Specification activities defined new Uses Cases.

TD4.3 Booking and Ticketing									
2015	2016	2017	2018	2019	2020	2021	2022	2023	...
Finished: IT2RAIL, Co-Active, MaaSive						Ongoing: ExtenSive, Ride2RAIL			

During 2021, 3 deliverables were planned out of which 3 were released, corresponding to the specifications and implementation done for the Final Release of the IP4 solution.

Since the beginning, TD4.3 has accomplished 100% of the planned work up to the end 2021, which represents approximately 90% of the overall TD.

TD 4.4 Trip Tracker

The overall objective of the Trip Tracking system is to assist a traveller throughout his multimodal journey in respect to any obstacles that might occur during his trip. Technologies that accurately and timely notify the traveller of those unforeseen difficulties on individual trips will be used. In cases they arise alternative routes will be provided to limit any impacts on them. When a disruption occurs, Trip Tracker will provide assistance by calculating with a multimodal approach both whole new itineraries door to door, and from the current position or even only single legs. It will analyse and correlate available static data (such as timetables), dynamic data (mainly real-time data) and passenger data (like preferences, locations). The architecture of Trip Tracking foresees not only to easily remove service providers and/or event sources but as well to add new and upcoming services is it a transport service provider or specific event sources bringing benefit to the travellers.

TD Progress

Two projects have contributed to the development of TD4.4 during 2021. These are CONNECTIVE (integration into the Interoperability Framework) and MaaSive (IF integration, Data and Event handling). The overall progress is in line with the plan in the S2R MAAP.

The basic idea of a trip tracking system was designed within IT2RAIL (LP) comprising the activation, disruption detection and alternative managing of an itinerary. S2R IP4 project ATTRACKTIVE expanded the architecture of this trip tracking system to a modular one consisting of the Tracking Orchestrator, different partial Trip Trackers and the corresponding Event Source Management. Results were demonstrated through the final release of ATTRACKTIVE which is as well the Alpha release of COHESIVE on the final event of that project. The developed architecture of Trip Tracking was improved further, towards an even more flexible one. This was done by integrating it into the Interoperability Framework of the IP4 ecosystem. It enables the integration of a new partial Trip Tracker for new modes, new operators, or additional information for e.g., specific geographical areas without modification of the Tracking Orchestrator.

One of the main tasks for 2021 was to further stabilise the complete system. Specifically, the integration into the Interoperability Framework was finalised. On top of this, the integration of a more versatile Complex Event Processing (CEP) engine was developed. It enables operators to flexibly modify

the rules, which are taken by a partial Trip Tracker (pTT) to inform travellers in a more versatile way. Tracking information can be provided in accordance with specific needs and situations of Travel Service Providers.

An additional step forward is the integration of machine learning systems to take travellers behaviour into account. The component receives Trip Tracking activation information from travellers to start an analysis of users’ past trips. The Implementation of this function was finalised in 2021 by testing the entire function within the IP4 ecosystem. As a result, travellers detected as commuters, are provided with better-suited trips.

As part of the improvement of Event Sources to further help travellers, anomaly detection methods were integrated. These methods allow getting insights of collected data, in order to help make proper decisions. In short, patterns are identified in data that do not conform to the notions of normal behaviour. In TD 4.4 vehicle average speed modelling was integrated and finished in 2021. The aim was to detect vehicles’ speed for public transportation networks through mobile sensors. Using historical data from such sensors, it is possible to calculate the average speed of the transportation services during each day and hour. This knowledge is used in combination with detecting differences in the real-time speed of the services (through mobile positioning). By comparing the two values it is possible to generate delay events (anomalies).

Already in 2019, several partial Trip Trackers have been integrated into the IP4 ecosystem to demonstrate the independence of interfaces. These systems are still running and are still used to prove the design and performance of the system. In 2021 the system was tested for dedicated Operators, however, due to the Covid-19 situation the pilots needed to run partly as In-House tests. The solution is developed as TRL 5/6 and will finally be tested as Beta Release in early 2022. In addition, S2R planned virtual Innovation Days in December 2021.

TD4.4 Trip Tracking									
2015	2016	2017	2018	2019	2020	2021	2022	2023	...
Finished: IT2RAIL, ATTRACTIVE, MaaSive, MY-TRAC				Ongoing: Extensive, Ride2RAIL, IPMaas					

During 2021, 2 deliverables were planned out of which 2 were released.

The Trip Tracker overall demonstrator targets TRL 6/7. Since the beginning, TD4.4 has accomplished 100% of the planned work up to the end 2021, which represent 80% of the overall TD.

TD 4.5 Travel Companion

The overall objective of the TD 4.5 Travel Companion is to research, implement and evaluate a seamless and interoperable platform offering new levels of interaction between travellers and transport stakeholders along with an innovative ubiquitous adaptive front-end to the global transportation service ecosystem.

Thanks to their own personal and secured ‘Travel Companion’ travellers will have access to all travel services needed for the journey (shopping, booking, ticketing, trip tracking, preferences, cancellation, ancillary services as well as novel forms of experiences) which will extend and transform the journey to a real door to door experience.

TD Progress

The TD 4.5 activities in 2021 rely on works performed in MaaSive and Extensive projects. Both of them provide and enhance solutions to improve traveller’s journey.

During this period efforts were made to complete the implementation started to ensure a seamless and interoperable solution based on MaaS approach for the travellers as well as transport service providers. A number of modules have been implemented and tested, e.g. Multi-modal entitlement management, a trip informer system as well as the mixed reality solutions. During this year, the technical developments finalize the work started to enable the management of entitlements and tokens in order to allow the traveller to retrieve them for validation and inspection purposes. Capabilities such as fraud control, to prohibit users to issue offers during the inspection, and management of Mobility Package (MP) where users can purchase MP and use it during the shopping and issuing flows were completed, as well as the updates of the travel informer and arranger.

During this period, work started for the specification of the usage of the Digital OnBoarding for registration based on biometrical traveller's data.

Besides the achievements of the Travel companion personal application, work has been accomplished to enhance the Travel Companion Web Front End. Travellers can now access to the webspace to modify their preferences, book a trip or see their already booked trips. The users can create a claim and view all the invoices paid as well as download them in PDF format.

To go even further, specification work is being carried out to enable the user to have access to additional features:

- User purchases a Mobility Package through the Web Portal Travel Companion,
- User purchases an offer through the Web Portal Travel Companion,
- User registers on the ecosystem through Google account on the Web Portal Travel Companion.

Providing all relevant information in a user-friendly way is also one of the challenges of 2021, a map-based interface as a new module of the Travel Companion – Personal Application was then specified. This new interface aims to display relevant POI in the vicinity of the users. In parallel to this interface a collaborative space was specified during this period. This new interface will allow the travellers to create (disruption, incident, emergency routes, and status of equipment at stations ...) or react in an existing event. This will serve both travellers and TSPs allowing the analyses of real-time events and comments provided by the travellers.

To improve traveller's interaction with the travel companion a specification work was carried out to establish a new level of hierarchy for traveller information, this will allow hierarchy for the presentation of the increasing variety of results in intermodal trip planning.

During this period work was carried out to finalize the LBE in station experience and the modules created were loaded in the S2R LBE library. The user will just have to sketch up his scenario and use the modules already created. And in a few clicks creates easily mixed reality applications without any technical skills, import traveller information from the cloud wallet, publish them on the travel companion as well as on the HoloLens so they can provide attractive solutions and promote the local shops. The travellers will be informed directly on the Experience from any notification.

Thanks to these achievements, a demonstration was made in Toulouse Train station with a traveller hearing the HoloLens and testing the first prototype of a S2R Mixed Reality Experience including animated virtual characters and interactive digital content. This experimentation demonstrates what future experiences might look like.

The concept of traveller experience is in constant evolution in order to fit the general public expectations for smoother and more agreeable/entertaining door to door journeys. With the

implementation of group travelling, we wanted to enhance the traveller experiences in order to allow travellers to interact remotely and meet physically. To ensure these interactions an automatic orchestration of multiple individual experiences is needed.

During this year work was carried out to specify the tool that will enable the orchestration of the journey of multiple travellers (e.g. groups, families, friends travelling together or through different means). A specific tool that will help TSPs to interact directly with travellers and allows travellers to interact directly between them.

Further work has been initiated this year to create a synergy between IP4 and IP3 in the area related to the improvement of customer experience. The objective here is to exploit the work carried out in the framework of IP3 in order to improve the travelling experience by setting up station infrastructure information to the traveller including voice assistance.

During this period a specification was carried out and a set of use cases was identified. Thanks to the outcomes of the In2stempo project the Travel companion will be enhanced by voice assistance for travellers when moving at the station or its surroundings and a navigation library that will provide navigation instruction in the Jurata station through 3D models and Digital Twins as well as POI position and status. The sensors available in this station will be used to detect the position of the travellers and overcome the obstacles already encountered in previous projects for indoor navigation.

In addition, particular attention was paid to aligning our developments with the OC (IP4MAAS) collaborative project timeline in order to be able to deliver the project functionalities integrated and test, to be ready for their scheduled Pilots.

TD4.5 Travel Companion										
2015	2016	2017	2018	2019	2020	2021	2022	2023	...	
Finished: IT2RAIL, ATTRACKTIVE, MaaSive, My-TRAC						Ongoing: RIDE2RAIL, EXTENSIVE				

During 2021, 6 deliverables were planned out of which 6 were released. Since the beginning, TD 4.5 has accomplished 95% of the planned work up to the end of 2021, which represents 85% of the overall TD.

TD 4.6 Business Analytics

The TD will provide a common business intelligence foundation for all products and services transport providers based on the access to open-ended web of transportation data offered by the Interoperability Framework (TD 4.1).

Based on descriptive, predictive, and prescriptive analytics using multimodal data sets generated by the Travel Service Providers and by the services developed in IP4, the TD will help the passenger carriers to better adapt their level of service to the passengers’ demand and to optimize their operations. TD 4.6 will also provide interactive and dynamic visualization capabilities.

TD 4.6 cooperated with IP4 and IP2 on specifying a solution on how to exchange data. The value of exchanging new data sets and information about passenger demand and transport supply capacity will be demonstrated in the Use Case to be implemented in 2022. The objective is to implement vehicle occupancy predictive analytics and on dwell times at stations, impacted by fluctuating passenger flows. By exchanging in real-time the information within all subsystems, prescriptive analytics will be developed for example for Train Management Supervision Systems (TMS) for real-time timetable optimization based on the demand (demand-based operations).

Data privacy is also an important issue in transportation: European GDPR – General Data Protection Regulation is effective since May 2018 and before GDPR adoption, other regulations were applied in the transportation context. To this end, anonymization services will be developed to guarantee privacy and confidentiality.

TD Progress

The TD R&I activities in 2021 relied on works performed in CONNECTIVE project (since 2017) and also in EXTENSIVE project (since 2021).

The TD adopts two approaches to develop Business Analytics. The first approach is a top-down approach: it aims to identify what information operators would value, regardless of any existing implementation and any data availability. This approach is complemented with a bottom-up approach which aims at managing real data from real operators, to be able to build robust big data platforms and to propose rich algorithms.

Based on interviews with stakeholders (CFM and OC projects, Rail Delivery Group and Rail Safety and Standards Board in UK), the top-down approach identified 47 use cases of interest for Business Analytics, grouped into 7 categories. The categories are displayed in the figure below:

1. Service Quality	2. Service Performance	3. Station Management	4. Resource Management	5. Demand Management	6. Revenue Collection & Distribution	7. Marketing
The door-to-door passenger experience, on public transport and at transport terminals.	Optimise public transport service to increase reliability and punctuality.	Manage transport terminals to improve passenger flow, reduce crowding and increase safety.	Optimise distribution and allocation of resources to increase efficiency whilst also considering sustainability and cost.	Understand patterns of demand and feed into time tables, scheduling & routing.	Provide better information about passenger travel to distribute revenue accordingly.	Improve the passenger experience whilst also providing extra lines of revenue.

In 2021, a finer analysis, based on the answers to the questionnaire and interviews with stakeholders, has been done to rank them and prioritize them. The most pertinent use cases are displayed in the table below.

Average Priority	No. of Responses	#	Use Case Title
2.56	8	1.6	Improve support for passengers with disabilities
2.44	9	2.2	Real-time prediction of delays
2.33	8	1.1	Accurate journey time prediction
2.22	8	2.1	Mitigate network disruption through personalised communications
2.22	6	4.2	Improve energy efficiency
2.11	9	1.2	Real-time train availability
2.11	8	5.5	Data-driven robust timetabling
2.11	6	1.10	Understand use of trip tracking
2.00	8	5.2	Manage demand in response to predicted delays
2.00	7	4.4	Improve assignment of rolling stock
2.00	7	5.4	Analysis of multi-modal journeys from origin to destination
2.00	6	5.3	Target messages and advertising to reduce overcrowding due to planned event

For these ‘top’ use cases, further analysis is currently done to characterize them in terms of technical complexity, business value and customer Requirement. Results will be presented in 2022. These ‘top’ use cases have also been crossed with the bottom-up use cases that are developed. The objective of these use cases is to: optimize timetables and to adapt dwelling time in the station, regarding the predicted demand (that is close to use cases 5.5, 5.2 and 2.2 in the table above); optimize bus route planning regarding multimodal transport offer (that is close to use cases 5.2 and 6.4 in the table above);

minimize the impact of maintenance activities on the railway attractiveness (that is close to use cases 2.1 and 5.2).

The Business Analytics platform is based on a common architecture across the partners, with different implementations done by each partner, to allow testing and benchmarking of a large variety of components. In 2021, the three big data platforms have been enriched and tested with the data collected and development done in the different use cases. The platforms have been developed to handle large datasets (from >100Gb to >10Tb), representing a large variety of transportation data (ticketing data, sales data, supervision data, contextual data...).



A new enrichment of the architecture has also been done in 2021. Indra developed a specific section in the operator portal called Portal BA where the output generated by the results of all the bottom-up use cases are made available to the operators in order to make the best business decisions. The figure below shows the process of the integration of the dashboards into the operator portal.

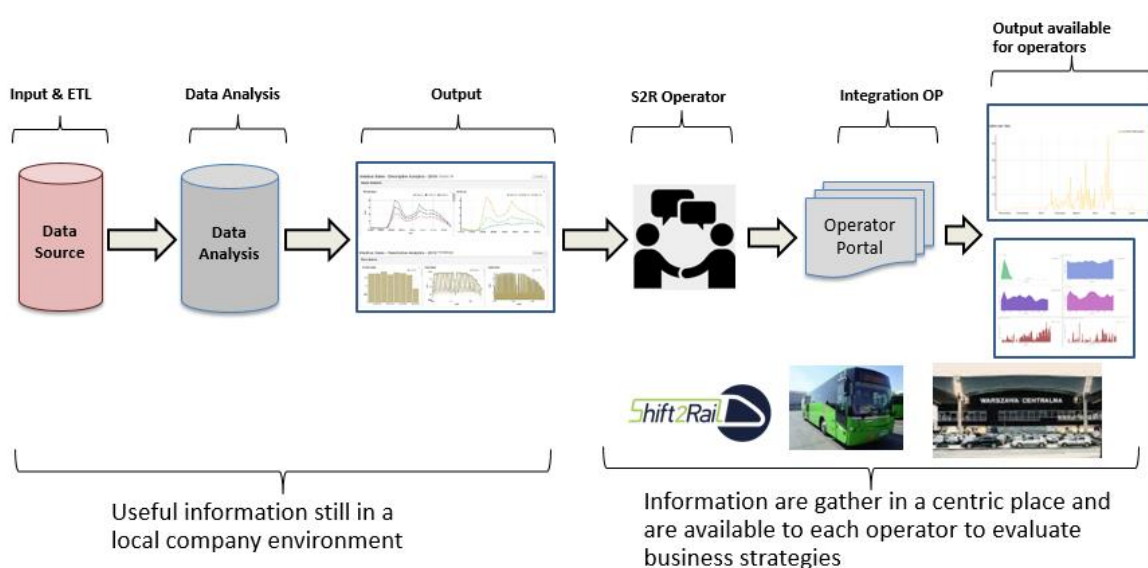

In the bottom-up approach, the development of the different use cases helped to identify important features and key information that is necessary to perform rich analyses. In particular, in terms of data management, Origin and Destination (O/D) matrices are mandatory for most of the analyses that interest operators. But existing and available data often doesn't allow to build these O/D matrices and to know where people are in the network. We developed a set of algorithms to answer these challenges: to build O/D matrices based only on partial information (entry data), to build passenger flows inside the network with simulations.

With these enriched data, processing chains combining Descriptive, Predictive and Prescriptive Analytics have been developed to help transport operators with decision support tools offering results directly operational for them. A large set of algorithms and tools have been developed. It includes classical time series algorithms, Machine Learning and deep learning algorithms, and optimization techniques for decision support.

New visualization components have been added, to allow more dynamic visualizations, and virtual reality has been enriched with real data. Besides these visualizations, more operational visualizations have also been developed to be used in a more straightforward way by TSPs.



Dashboards (with Kibana)



Dynamic visualizations (with Kepler)

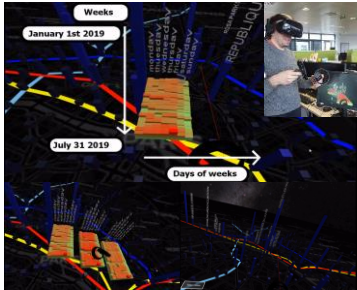

Virtual reality



Operational visualizations (decision support results)
Space-time diagram with platform/train occupancy

Last, as the above results concern mostly TSPs data, a new Use Case has been added to analyse the potential of the data collected within IP4 ecosystem with the Travel Companion to prepare potential insights from future pilots. Some initial results are displayed in the figure below.



In this figure, the population of data presented in the Travel Companion represents some results regarding all test activities conducted so far during tests and pilots across various projects. Even if the data are only of technical nature, the results show the potential of using Travel Companion data with results covering various European countries (Spain, Portugal, Germany, Netherlands, Czech Republic and others in the figure).

These works will continue in 2022 and the different processing chains will be integrated in demonstrators and the different visualizations in the Operator Portal.

In 2021, there is no official deliverable.

Use Case Specifications have been produced during 2021, and the implementation will take place during 2022. The Use Case Specifications are based on technical studies and interviews of domain experts, focusing on the final value for the Transport Service Providers and the Passengers.

Work in this TD will continue until 2022, supported by the activities of projects CONNECTIVE and EXTENSIVE.

TD4.6 Business Analytics									
2015	2016	2017	2018	2019	2020	2021	2022	2023	...
Finished: IT2RAIL			Ongoing: CONNECTIVE, EXTENSIVE						

Since the beginning, TD 4.6 has accomplished 80% of the planned work up to the end of 2021, which represents approximately 70% of the overall TD objectives.

ITD 4.7 Integrated Technical Demonstrator

At the core of the ITD lies the objective of opening the transportation ecosystem to new business actors, able to rejuvenate the transportation ecosystem technologies and business models, thus achieving the goals of European leadership in the market. The ITD will release, on a regular basis and for all TDs, successive versions of enriched deliverables, from early conceptual prototypes to the final version. It will act as the orchestrator of other TDs' developments and will ensure the systems approach to integrate the different TDs' results.

ITD Progress

During 2021, the ITD continued to address the coordination of IP4 activities and support internal technical discussions to guarantee consistency among projects. Another focus from ITD was the coordination of the interface between the CFM projects and the Open Call projects aiming to have integrated coherent demonstrations. The regular tasks such as activity planning and follow-up,

definition and production of the technical management documentation used to guarantee effective monitoring and control of activity and its progress were also included.

Activities in ITD 4.7 are mainly handled and managed by the project COHESIVE supported by the other CFM projects (CONNECTIVE, Maasive and Extensive - providing technologies) and by Open Calls (Ride2Rail and IP4MaaS - preparing and running pilots).

For 2021 ITD7 had several targets:

- Execute Shift2MaaS pilots on three sites (Lisbon, Málaga, Central Eastern Corridor)
- Perform a successful demonstration on MaaSive final event
- Integrate FREL results from MaaSive project
- Integrate of the second main release, Beta release
- Identify performance issues and improve ecosystem performance
- Maintain test and demonstration environments
- Plan upcoming OC pilots from Ride2Rail and IP4MaaS
- Perform a successful demonstration on S2R Innovation Days

The support and execution of the pilots were done at the beginning of the year. All the foreseen stakeholders were integrated and allowing them to be part of these pilots (even if with different levels of integration). KPIs related to the result of questionnaires to the testers were compiled, as well as IP4 AMPI's from the perspective of these testers were analysed.

Pilot results and Beta release presentation were performed in June, together with the presentation of the overall IP4 ecosystem and the recently integrated functionalities for travellers and transport service providers.



- Travel Companion Web Frontend
- Guest users
- User Profiles
- Trip Sharing
- Group Travelling
- Travel arrangement
- Mobility packages (buy and consume)
- Best Price optimization
- Passenger rights
- Multiple tickets on one embodiment
- Mixed-Reality experiences
- POI Library (My-TRAC project)
- Commuter detection
- Travel Companion for Kids



- Mobility packages (creation)
- Asset manager (SPRINT project)
- Business analytics portal
- Token generator and validation engine
- Inspection app with fraud control
- Trip tracking CEP configuration
- Mixed Reality composer
- CRM portal

All the tests to the Beta release functionalities have been done under the test environment, of which some technical issues have been handled. Before the end of 2021 all the results about the demonstration environment were published and made available for other pilots.

During 2021, a substantial effort was put in coordination of the most recent open calls which intend to pilot the IP4 ecosystem. This is due to the large number of pilots planned on the open calls, which will run in parallel to other CFM projects development phases. That fact represented a risk for the projects and has been followed carefully. Re-planning of timeline of pilots has been done, Extensive is preparing one amendment to better adapt the project to the necessary open call support.

During the year a number of workshops were done between CFM and OC with the following goals:

- Introduce IP4 ecosystem objectives and functionalities
- Identify TSP services available to be integrated on pilots
- Match the goals of both projects
- Rework the planning of project
- Identify necessary integration activities
- Guarantee iTD7 support after COHESIVE end

The following timeline reflects the current integration and pilot planning which will be held in two phases. Phase 1 during 2022, using Beta release including Interoperability Framework updates and Phase 2 in 2023, with piloting the final results.

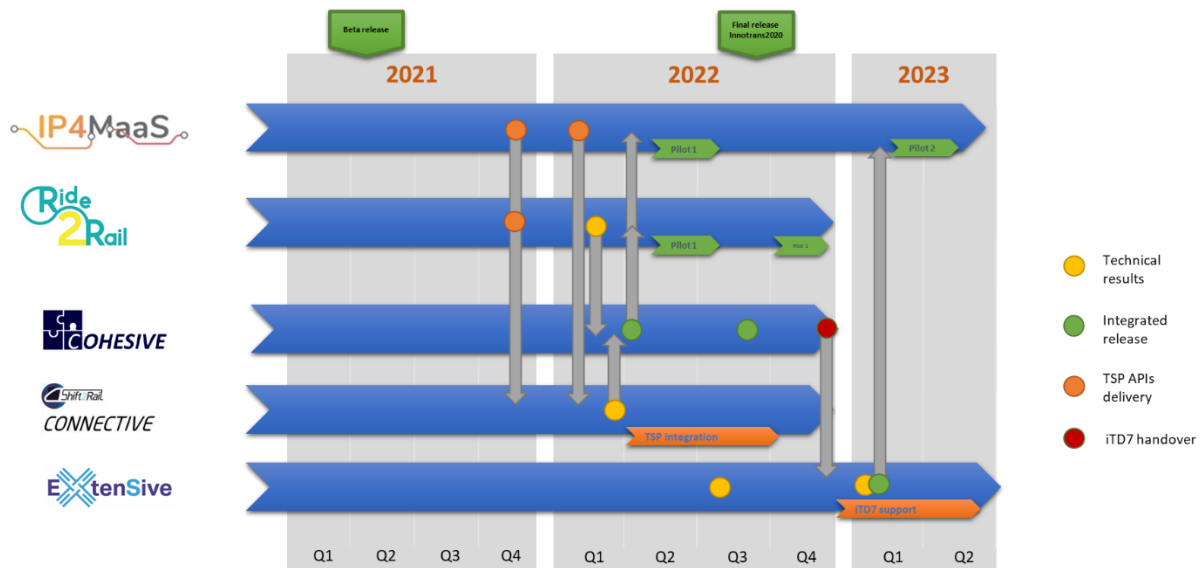

As it can be seen in the planning figure, the second phase of the pilot will be executed only in 2023, after the integration of the final IP4 release, with continuous iTD7 support of the CFM project.

The planned sites included in each pilot phase can be seen in more detail below.

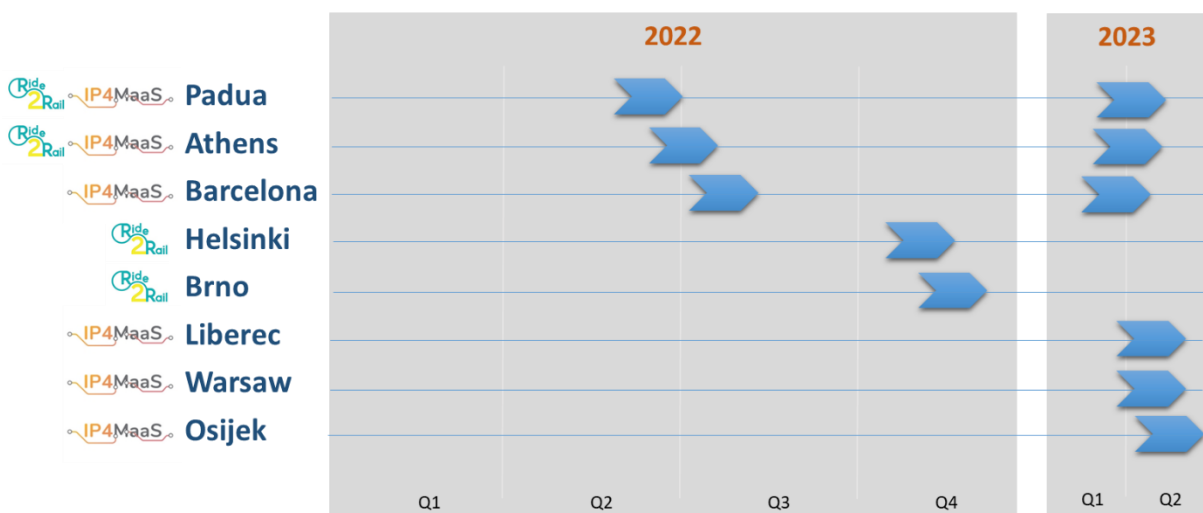

In 2021, two new IP4 Advisory Board Summits were held presenting the progress of the project and collecting feedback from the Advisory board member participating in the sessions.

Delays in MaaSive project closure impacted the production of the Beta release documentation. This was recovered during 2021 and it was possible to execute the Beta release demonstration in June 2021.

During 2021 the iTD7 has also progressed on the Route to Market report, where the discovery and gathering phases were finished and the execution is now in place. The next step is to enter the gathering phase for the upcoming exploitation plan.

TD4.7 Integrated Technical Demonstrator									
2015	2016	2017	2018	2019	2020	2021	2022	2023	...
Finished: IT2RAIL, SPRINT, Shift2Maas						Ongoing: COHESIVE, IP4MaaS, ExtenSive			

During 2021, 3 deliverables were planned out of which 3 were released. Since the beginning, ITD 4.7 has accomplished 83% of the planned work up to the end of 2021, which represents around 75% of the overall TD.

1.4.5. IP5 Technology for Sustainable and Attractive European Rail Freight

The picture below gives a visual perception on where the TDs will introduce improvements.

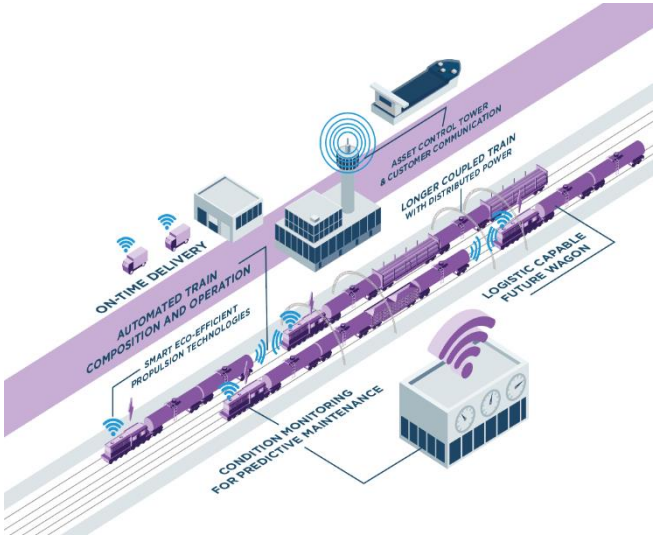

This IP aims to improve the cost competitiveness and the reliability of freight services of the rail sector in order to meet the ambitious objectives of almost doubling the use of rail freight compared to 2005. This will allow achieving the White Paper objective of a shift of 30% of road freight over 300 km to modes such as rail or waterborne transport by 2030, and more than 50% by 2050. Rail freight must be in a position to offer a cost-effective, attractive service to shippers that helps to take freight away from the already-congested road network. Work focuses on different market segments with specific technical and operational characteristics and needs.

TD5.1 Fleet Digitalisation and Automation

This TD targets the adoption of two global megatrends for freight rolling stock: Condition Based Maintenance and automation based on DAS/ATO and Digital Automatic Coupling for freight trains. DAC is an important boost in competitiveness of the rail freight market, not only delivering increased capacity in the system, but also enabling digitisation of rail freight, which leads to smart, connected rail freight that offers the necessary information for improved services. The TD focuses on areas such as condition-based and predictive maintenance (CBM) of locomotives and wagons, automatic coupling and freight DAS and ATO, the latter is developed in close collaboration with IP2.

TD progress

This TD progresses through the ongoing work performed in ARCC, FR8RAIL, FR8HUB, FR8RAIL II, FR8RAIL III and FR8RAIL IV as well as the Open Calls, LOCATE and SMART II. These projects build in the initial work carried out in INNOWAG and SMART all closed by 2020.

In the area of CBM the overall ambition can be summarized as follows:

- Development of a condition-based and predictive maintenance strategy and roadmap, as the umbrella for all asset intelligence projects in IP5,
- System engineering incl. data crunching, modelling, behavioural research & development of mass data infrastructure for live pattern recognition and recommendation of measures,
- Process conceptualization, testing, validation and change management in the implementation.

In 2017 the focus was rather to classify the top components and feedings. Since 2018, the aim was to analyse the data of these components, which is one of the most essential tasks within CBM. The continuous analysis of the data of these components led in 2019 to a development of an equalized maintenance program for a possible extension of the maintenance intervals. Also, first dashboards were developed to stream live data using intelligent algorithms. In 2020 the CBM did progress significantly by producing and testing a suite of sensors that will be the first tier of the CBM architecture, capturing from actual vehicles key data for vehicle maintenance. In addition, the innovation has to be highlighted in developing specific locomotive sensors to capture health status of lubricated systems within the fluid stream. These sensors were installed and tested in different Deutsche Bahn diesel locomotives and form a key part now of maintenance dashboards where parameters like temperature, electrical conductivity and permittivity, water content, and corrosiveness are being recorded. Whilst the main focus has been diesel locomotive dashboards, there are plans to extend it to axle bearings and transformers. Vehicle sensing for wagons is also present in the CBM maintenance strategy and in 2020 the focus was on modelling and capturing data over wagon springs conditions and bogie performance, where a set of KPI has been identified and modelled, making progress on defining admissible thresholds.

In 2021 progress was achieved in the field of user-centric design of CBM dashboards. To do so, the user is in the centre of the development process, to develop an efficient and useful dashboard that can be used all over Europe. In a first step, the design of the common structure in which CBM Use Case Results need to be saved as template for all use cases. Testing dashboards against given use cases was performed throughout 2021 where a first draft for the Use Case “temperature anomaly” is already available to our locomotive engineers. The next steps will be the integration of additional use cases.

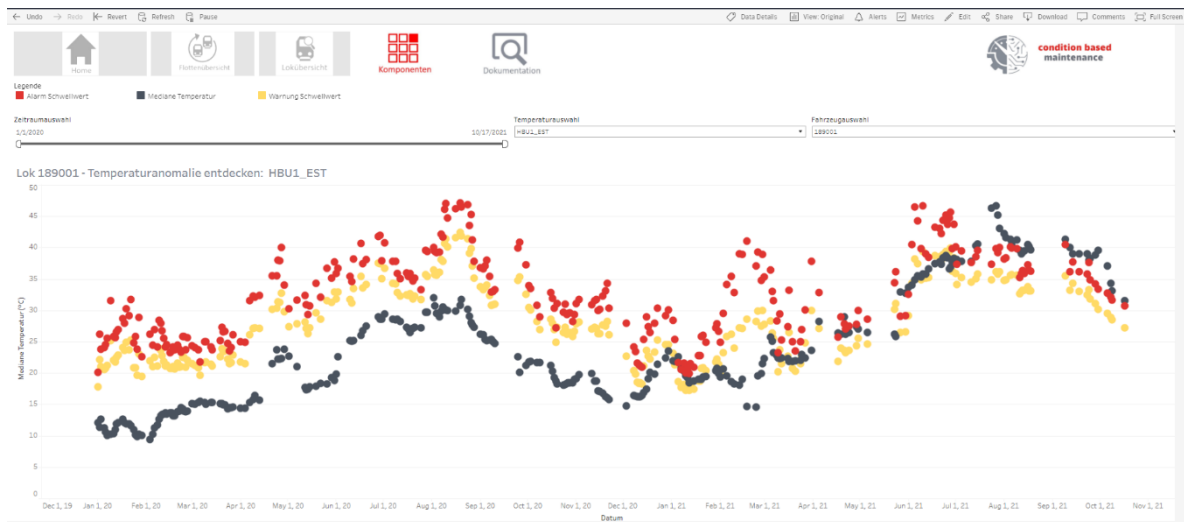

Figure: Draft Temp CBM Dashboard

With the development of the application LocoBorderWatcher based on the platform LocoInsights a web interface was developed allowing end users to quickly analyse the status of the fleet and each individual locomotive, if necessary. With this information the current traffic and deviations of the plan can easily be seen and needed adaptations be planned and performed. This reached milestone enables providing digital assistance for border crossing and vehicle handover procedures which today are time consuming and add undesired overheads to the total time of transport in the logistic chain. The system is developed around open-source technology, avoiding proprietary software, thus reducing the cost and preventing a vendor lock-in.

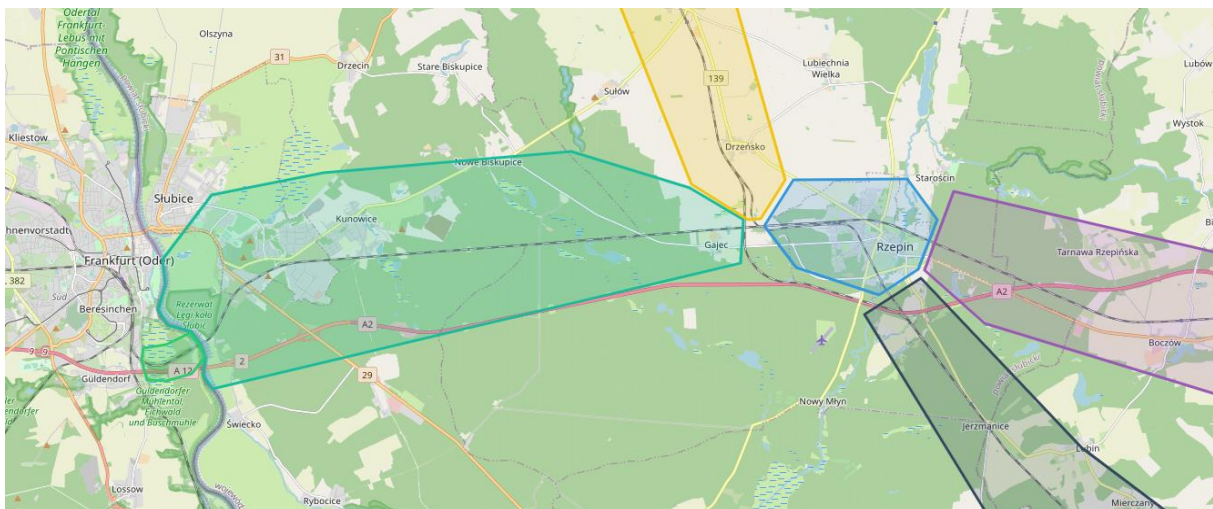

Figure: Defined Geo-Sectors

With the knowledge gained, the upcoming handover process of locos and trains is accelerated. Furthermore, the app contains the following additional functionalities:

- Locos with expired permissions or not enabled for operations in a certain country are identified in advance, an alternative locomotive can be ordered in time.
- Upcoming locomotive drivers do not lose time because they will know when to start their work at the handover position.
- Upcoming maintenance action is announced, e.g. based on mileage thresholds, and can be also planned in the destination country with the knowledge of the planned route for the next days and the current value of the lifetime indicators (output of CBM monitoring).

In 2021 the focus has been - as a first step - on the procedure of border crossing between Germany and Poland. As needed, information and regularities differ a lot depending on the countries involved, an intense collaboration with the persons in charge was necessary during the development phase. In the beginning the German-Polish border was prioritized due to its important corridor and amount of traffic. Later border crossings to other European (e.g. France) and non-EU countries will be in focus.

The solution collects telemetry data from our locomotives, including GNSS and diagnosis data. This allows analysing both the locomotives' movements and its health status while on track. By identifying traffic that is approaching the border, we can generate notifications for this traffic to help planning and processing the border crossing trains. These notifications are fed into a web application visualising loco positions based on GNSS data, together with the notifications and health-status information.

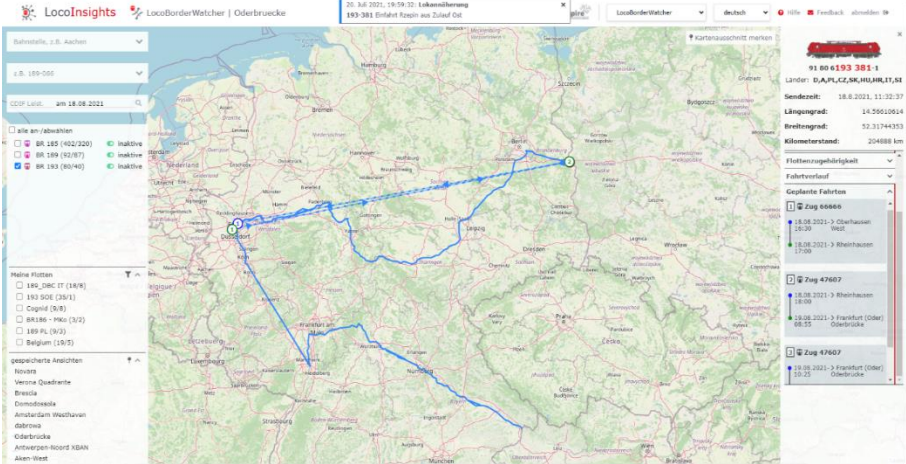

Figure: Web interface

The system makes use of a web-based app as a base and built a platform that allows implementing multiple products for various use cases which we called LocoInsights (LI). For the digital assisted border crossing and handover process, we decided to develop the application LocoBorderWatcher (LBW), that will allow us to monitor border crossing traffic and be informed about possible incoming traffic. It is based on a map that can display the positions and movements of the locomotives together with the notifications about approaching traffic.

In 2021, maintenance feedback loop from workshops - secure continuous improvement process and sustainability started. This meant feedback from site about the executed maintenance actions ordered by the CBM-process and served as validation process within the CBM strategy. This feedback did help improve the CBM system and technical guidelines were developed. This process will carry on and continue in 2022 with further pilot projects to be tested in Q1/Q2 2022. Additional requirements are defined and will be implemented until end of Q2 2022.

Developing Digital Automatic Coupling was also important in 2021 as a carry-over of 2020. In 2020, the S2R JU launched EDDP (European DAC Delivery Programme) that involves the most relevant stakeholders, in a Joint Sector activity, with the goal of aligning all the DAC initiatives into a single program, oriented to define a standard solution. As a result, TD 5.1 in 2021 supported the EDDP by performing the extensive tests in Sweden from January to April 2021. Four DAC systems from four different suppliers were under test. Those suppliers were Voith, Dellner, Wabtec and CAF. The couplers were tested on 9 different wagons. This test campaign in addition to the one carried out in DAC4EU project served as the Validation Platform for the EDDP and collaborated in selecting Scharfenberg as latch mechanism for the EU. The tests, both in winter and summer, were carried out with the assistance of Green Cargo.



EDDP DAC Test

2021 meant the end of ARCC project, where successful ATO tests in collaboration with IP2 took place. For ATO the goal was to reach a working partnership with the ATO suppliers of IP2 and a mature set of technical documentation for the ATO test runs in Switzerland to apply for ATO testing admission. The whole test runs have been finalized and accomplished successfully in 2021. DB Cargo AG as the project lead delivered in 2021 the dissemination activities as a webinar in collaboration with Network Rail Pilot GoA 2, final report, lessons learned and review of current X2Rail 4 ATO specification workstream.

Testing a new product is always a challenge, and in this case, it was required bigger endeavour as the test was developed during normal commercial traffic. This meant that track access was not always available and required to wait and re-schedule test execution depending on actual commercial traffic. During the test runs of the ATO over a heavy loaded and long freight train the following findings were recorded as challenges for the ATO system (Start / Stop under gradient conditions, Brake release, initial set up values and parametrization to determine the real resistance of the train and managing train dynamics). To achieve full independence between hardware and software (as proposed by OCORA) a full specification of the Application Programming Interface (OSI Layer 1 - 7) would be needed. The current specification leaves room for interpretation to allow a vehicle-specific connection between ATO-OB and necessary vehicle functions for existing designs. Lessons learned were derived from this demonstration.

Human-machine interface and operational topics must be fully respected for the further development of the ATO specification and products to avoid market failure and social impact.

The tests have proven that ATO delivers a significant potential for improvement of rail freight transportation in terms of efficiency and operation quality. ATO technology can be the game-changer towards modal shift (from truck to freight rail) and CO₂ reduction, particularly for freight application.

The TDs will continue in 2022 in further collaboration with IP2 for the ATO to GoA4 specification developments.

2021 was a successful year for the TD yet heavily impacted by Covid-19, that not only limited field test trials and lab test availability, but also caused the number of working hours being reduced. TD 5.1 has increased its workload with FR8RAIL IV which is the biggest project in IP5 program. This project has added new tasks and deliverables to the TD.

TD5.1 Fleet Digitalisation and Automation									
2015	2016	2017	2018	2019	2020	2021	2022	2023	...
			Finished: SMART, FR8RAIL, INNOWAG, ARCC						
			Ongoing: FR8RAIL II, FR8RAIL III, LOCATE, SMART 2, FR8RAIL IV						

In 2021, 36 deliverables were planned out of which 22 were released. TD 5.1 has reported having accomplished 70% of the planned work up to the end of 2021, which represents around 65% of the overall TD.

TD5.2 Digital Transport management

This TD is targeting the digitisation of processes to optimise service planning and operation thanks to real-time data gathering, steering, operation, and coordination of intermodal transport at higher speed. This supports better utilisation of available capacity, by optimising access and operation of local hubs which are essential but cost-intensive subsystems for rail freight business. The TD is looking into improvement of effectiveness in marshalling yards and terminals with the introduction of innovations in real time information management (e.g. intelligent video gate). The key challenge is to improve the interaction between yards/terminals and the network, thus reducing the lack of information and adding new decision tools that will increase punctuality and capacity.

TD progress

This TD is currently progressing through the ongoing work performed in FR8RAIL II, FR8RAIL III and FR8RAIL IV. These projects build on the initial work carried out in INNOWAG, SMART, ARCC, FR8RAIL and FR8HUB, all closed by 2021.

The TD 5.2 is built around the following building blocks:

- Intelligent Video Gate Terminals,
- Improved methods for timetable planning & Real Time management,
- Real-time yard management & SWL system.

The work on Intelligent Video Gate (IVG) for 2021 was based on the successful prototype concept developed in FR8HUB which has now been continued within the framework of FR8RAIL III. 2021 has been a complex year due to Covid-19, nevertheless, a great deal of progress has been achieved regarding IVG and FR8Rail III. To start with a new location for the gate, in a dry port looking at the best possible integration with multimodal traffic. After solving some integration problems mainly derived from the pandemic the IVG was successfully installed and commissioned in summer 2021. The gate is now under operation delivering train data which is processed by Hitachi and Indra.

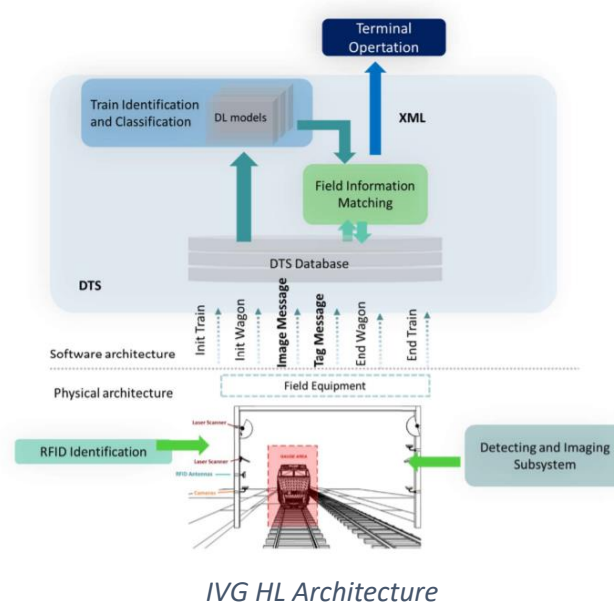

Although the localization is not the best for logistic purposes (meant to be at the terminal not in between) it will help the Port Authority deliver early dispatching information to container loaders

regarding the order of elements in the convoy, enabling a certain degree of automation in the crane-based loading system of the port.

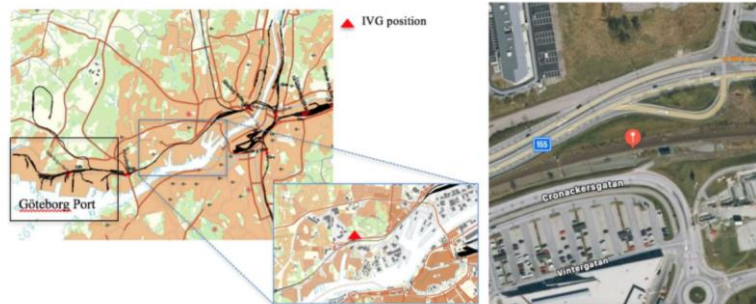

Localization of IVG in Sweden

Following the Technical Demonstrator plan a second gate has been used in Germany, but this time with no logistic purposes, but meant to serve as a tool to help easy CBM and train dispatching within the freight segment. The gate was installed by DB Netz but is meant to cover single wagon load DB Cargo needs. The gate is placed in the shunting yard, key infra cornerstone through which all wagons under operation need to pass through.

Synergies have been sought with Freight Automation, in particular regarding track side inspection through IVG and the train preparation process including the brake test process. For this purpose, the following could be inspected within the visual inspection for external control of the locomotive and wagons:

- First and last wagon number, complete train, brakes off
- Cables, hoses, pipes
- Wagon body and bogies
- Brake pads (where visible)
- Position of various air taps

The main focus so far is on IA and machine learning for images captured from cameras. This work is built upon the results of FR8HUB for wagon and container identification and matching with other data (such as RFID) also providing new functionalities based on images processing and information collected by the sensors, including automatic recognition of damages and defects.



Example of processed Wagon Image

The 2021 TD's goal for Improved methods for timetable planning & Real time Management Terminal and Yards was to move ahead in the development of the solutions identified for reducing the gap between planning and operation and developing methods for improving network management.

Progress continues by increasing TRL for the advanced real time network management for freight rail traffic. The focus has been on the coordination between traffic control, train drivers and yard management, three essential parts in the real time management of a rail freight network. Works on the final demonstrator started within FR8Rail III compiling scenarios for enhanced and integrated line-

and yard planning. The proposed demonstrator had a focus on the interaction between different systems and between humans using these systems, but also on the rail freight system perspective by the inclusion of the connection between the line and the yard. The demonstrator Integrates Planning Module M2 from Timo SW and the macro simulation SW Proton. Scenarios take as a reference Hallsberg – Malmö rail traffic taking into account both planned and unplanned traffic disruptions due to infrastructure maintenance work and infrastructure errors. Progress has been achieved as simulation/rendering times decreased from hours to order of magnitude of minutes, becoming closer to expected TRLs regarding response time for a commercial use of this kind of tool.

The overall TD progress metric did not evolve much compared to past years as the TD is finishing and needs success in the IVG at Malmö in order to complete TD results. Due to Covid-19 traveling restrictions (Italian, German and Spanish partners had limited traveling access) supply chain issues (pandemic-related delays in the reception of certain purchase orders) and installation issues (traffic restricted patterns) all deliverables engaged in this technical demonstrator got delayed almost one year. The project is back on track and did successfully install the gate by the end of 2021 and all base systems HW/SW are integrated.

TD5.2 Digital Transport Management										
2015	2016	2017	2018	2019	2020	2021	2022	2023	...	
Finished: SMART, ARCC, FR8HUB, OPTIYARD				Ongoing: FR8RAIL II, FR8RAIL III						

During 2021, 5 deliverables were planned out of which 2 were released. TD 5.2 has reported having accomplished 89% of the planned work up to the end of 2021, which represents around 80% of the overall TD.

TD5.3 Smart freight wagon concepts

This TD has the objective of delivering technical demonstrations of next generation running gear and wagons for freight. The next generation freight wagons will improve the competitiveness of rail freight logistics by providing more flexible and reliable high-capacity assets at competitive costs. This will be achieved by means of wagon solutions for the rail freight core market wagon & extended market wagon.

TD progress

This TD is currently progressing through the ongoing work performed in FR8RAIL II, FR8RAIL III and FR8RAIL IV. These projects build on the initial work carried out in FR8RAIL and FR8HUB, all closed by 2021, and also INOWAG which was closed in 2019.

The TD 5.3 is built around the following building blocks:

- Running gear and Core Market Wagon (CMW)
- Extended Market Wagon (EMW)
- Telematics and Electrification

In 2021 the work related to CMW has focused on the CMW bogie and on the CMW wagon. Progress in 2021 resulted in achieving enough design maturity to equip the wagon with Y25 bogies and DAKO Brake System – K block. 2021 proved that the high-energy brake disk did not reach enough maturity to be included in the final design, as lab tests did show that the disk was overeating. The result of the dynamometer test demonstrated that the thermal capacity of the new brake disc prototype, which is intended as its capacity to keep the temperatures at a level that does not compromise the disc safety, is not sufficient to fulfil the test requirements considered in the TSI. Lessons learnt identify better alloys

and further optimisation of the disc geometry as potential solution. With the aim of supporting CMW technological demonstrator (TRL6) DAKO Brake Systems have been used instead A two disk brake system from DAKO was chosen, and axles were designed for this.

CMW bogie shape is based on a U-frame employed for the new aluminium bogie frame. Moreover, coordination activities have been covered among different partners to cover fully the bogie: wheelset, brakes and Telematics & Electrification. During 2021 progress has been achieved and a new Aluminium bogie frame prototype based on a U-frame shape has been produced.

Aluminium bogie frame – 3D model

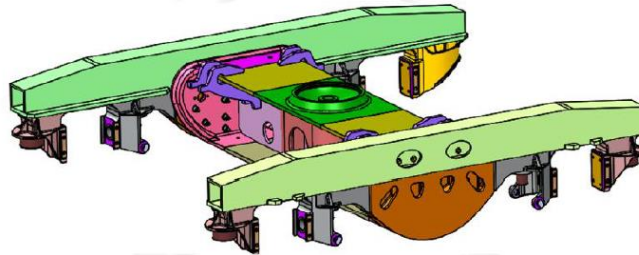

Aluminium bogie frame –mock up



Complete bogie with aluminium frame –mock up



Trial assembly



Aluminium bogie 3D model, assembly and prototype.

Noise reductions have been tackled by means of field test campaign. These tests were carried out on wagons that could be borrowed from real operation, among them the intermodal and tank wagons are considered good representatives for noise studies. All implemented measures that the noise campaign monitors are related and can be applied to CMW and FR8RAIL II bogie. A first extensive measurement campaign has been realised in 2021 with:

- 7 pcs intermodal wagons,
- 5 pcs tank wagon,
- several technical solutions and a number of different wheelsets designs were tested.

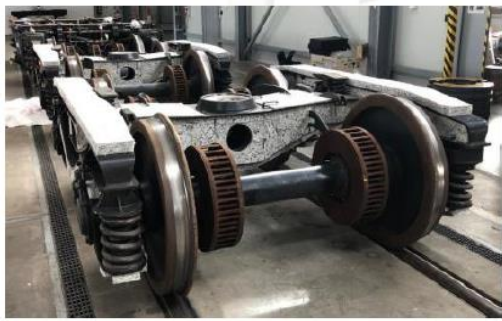

A number of wheelsets solutions have been employed for the noise field tests

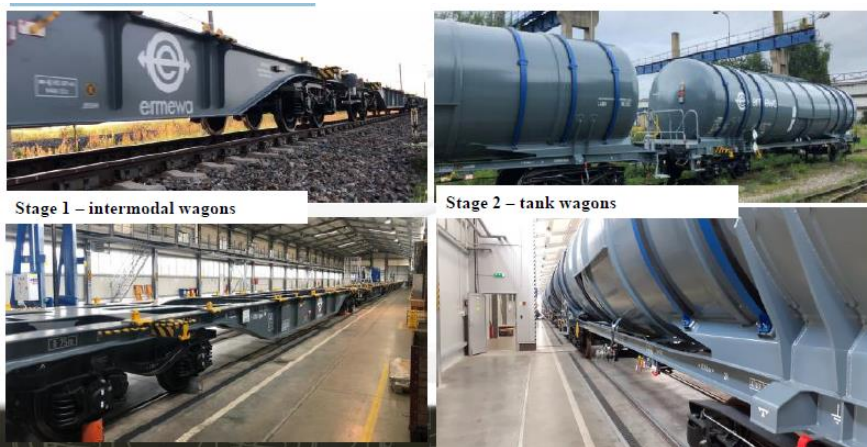

Stage 1 – intermodal wagons

Stage 2 – tank wagons

Wagons employed for the noise field tests

With regard to the development of the bogies for the tests in 2022, on the track Poprad (SVK) – Cerhenice (CZE), the required activities for the production of the U-frame production and two FR8RAIL II bogies have been covered in 2021 including the procurement for brakes and 4 wheelsets for 2022. These wheelsets for the CMW have been defined to fit the CMW, for real operational tests. An integration study of the new brake disc reference has been executed, and other secondary aspects more marketing-oriented like paint specification, as well as logos and decals, have been defined. The production of the wheelsets has started in Q4 2021, and the components will be ready for integration in Q1 2022.

In 2021 the work related to the Extended Market Wagon (EMW) continued with the development of concepts of the wagon in two sections:

1. Lightweight chassis design
2. Running gear development

In 2021 a three-dimensional design space of EMW was generated using the CAD generation program CATIA and then transferred to the Altair Hypermesh pre-processor for element discretization. The whole geometry was modelled using 8 node brick elements. The boundary conditions and relevant load cases based on European norms were applied to the model and the optimized load paths were then iteratively calculated using the solver OptiStruct.

For the static topology optimization, boundary conditions were implemented, and forces and load cases were derived from EN 12663-1. In order to increase the competitiveness and service range of wagon, besides the 20-foot Swap body containers, the standard container's size of 20-foot, 40-foot and 45-foot were also considered as a payload.

The maximum allowed payload per container is 17 tons. Furthermore, several load patterns and various load cases such as bogie traction were also applied in order to obtain realistic load patterns. In the figure below a number of the force application points and constraint points are shown.

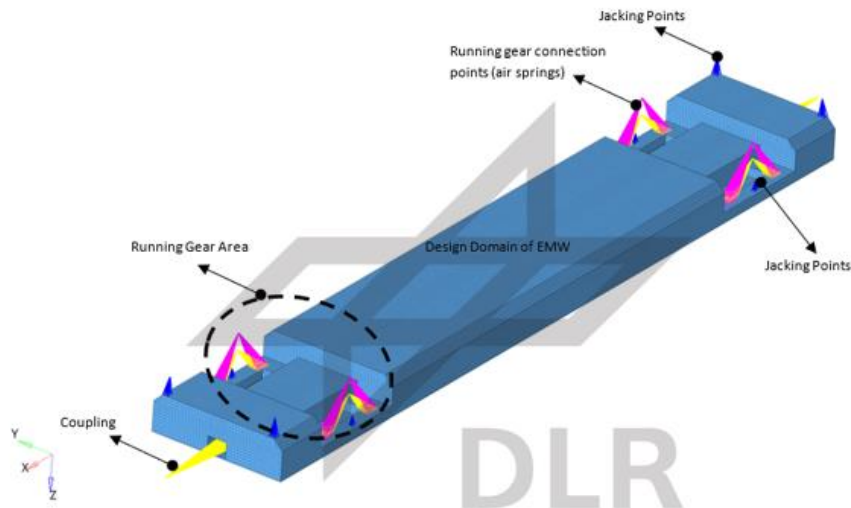

Model setup for topology optimization

By configuring the EMW design structure in this way, the maximum allowed payload of EMW and specific energy efficiency can be optimized. The topology optimization result is given in the next figure. By using this topology, a novel 3D design of wagon can be generated and significant weight reduction can be achieved. Thus, a higher number of payloads can be considered. This design concept has the advantage of increasing the competitiveness of freight rail transportation.

This process continued in 2021 in parallel with the running gear design process. The structural integrity with the running gear frame and relevant components were the parameters that affected the 3D design of the chassis was done. Additionally, the integration of DACs from two manufacturers was also considered. The design iteration is still ongoing and as a next step, strength calculations will be performed and final dimensions of the frames and beams will be obtained.

According to the running dynamics aspects, the EMW is a two-axle freight car for standard track gauge 1.435 mm. The EMW is equipped with two single wheelset running gears. Each running gear consists of a primary as well as a secondary suspension. The summary of the main design parameters is given in the table below and also illustrated in the next figure.

Description	Symbol	Value	Unit
Nominal track gauge	S	1'435	mm
Admissible speed	Vadm	140	km/h
Admissible cant deficiency	ladm	130	mm
Length over buffer	L	16'840	mm
Wheelset spacing	2a ⁺	10'260	mm
Wheel diameter	∅	850 770	mm mm
Nominal wheel profile		S1002	
Admissible static axle load		22.5	t
Vehicle masstare		12'000	tt
max. gross		45'000	

Main data of the EMW

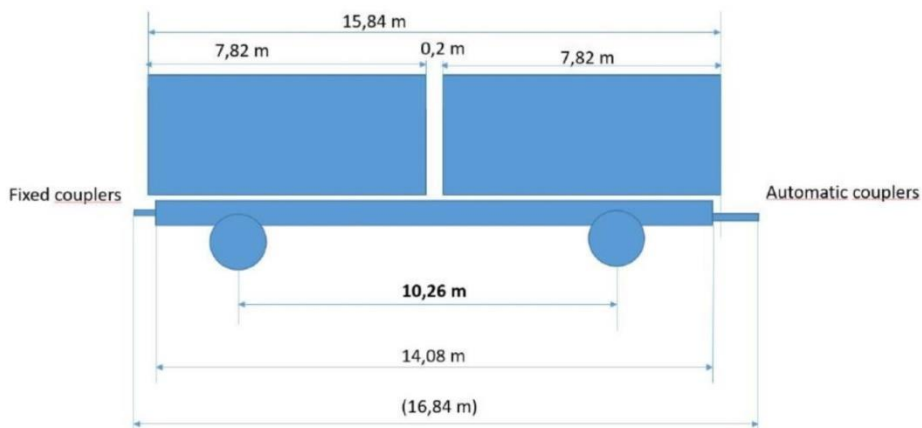

Overview of the EMW in terms of running dynamics aspects

The most recent version of the running gear is given in the figure below.

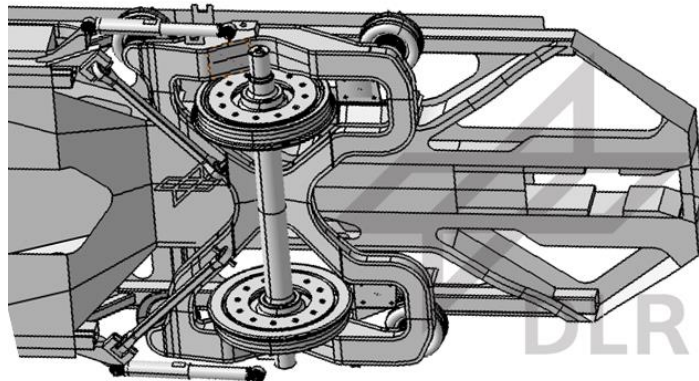

Overview of the new running gear for EMW

A new running gear frame was also developed due to the design and strength constraints of the running gear. In 2021 most of the engineering design activities have been executed, shifting from an initial early conceptual phase to a detailed engineering model, that will be later used for drafting and production. The production of this wheelset will start at the beginning of 2022, after the remaining bogie and car body parts are defined.

During 2021, activities related to the development and integration of the wagon subsystems, definition of the integration of Telematics and Electrification on the Wagon and field tests have been covered.

Furthermore, the functionalities and subsystems to be integrated in the demonstrator to be shown on the INNOTRANS 2022 have been defined and an integration and test plan was developed.

The Telematics and Electrification system for the EMW comprises the functions shown in the next figure, in an architecture based on the STI (wOBU) at the wagon and the LOBU at the locomotive. The definition of STI-System with LOBU/WOBU-concept, system architecture including energy supply architecture and algorithm for control and safety application to achieve full train integrity supervision have been further defined during 2021.

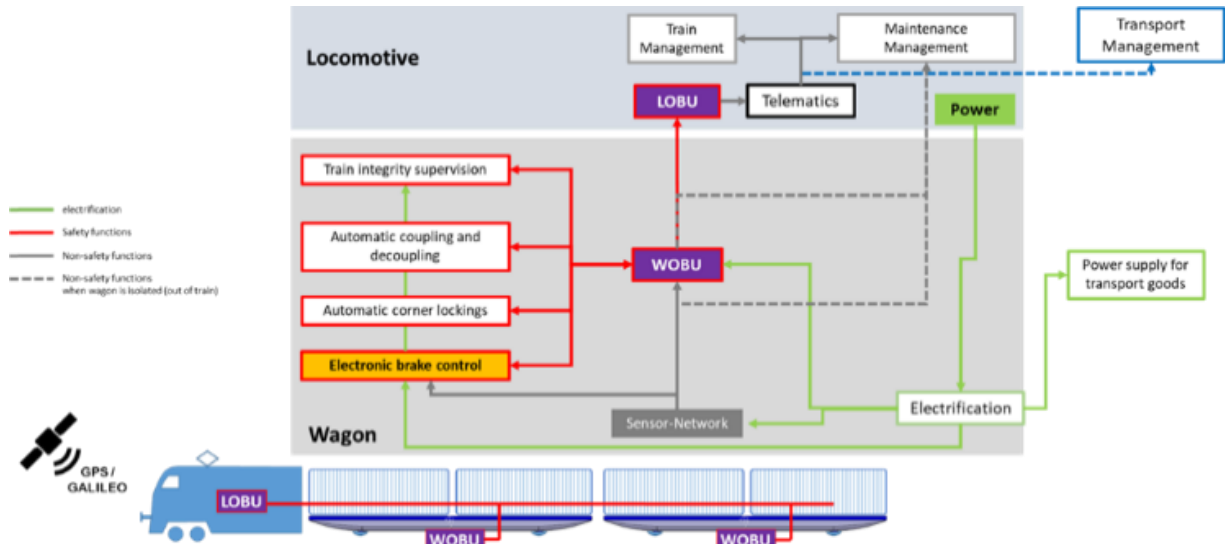

STI and its functions

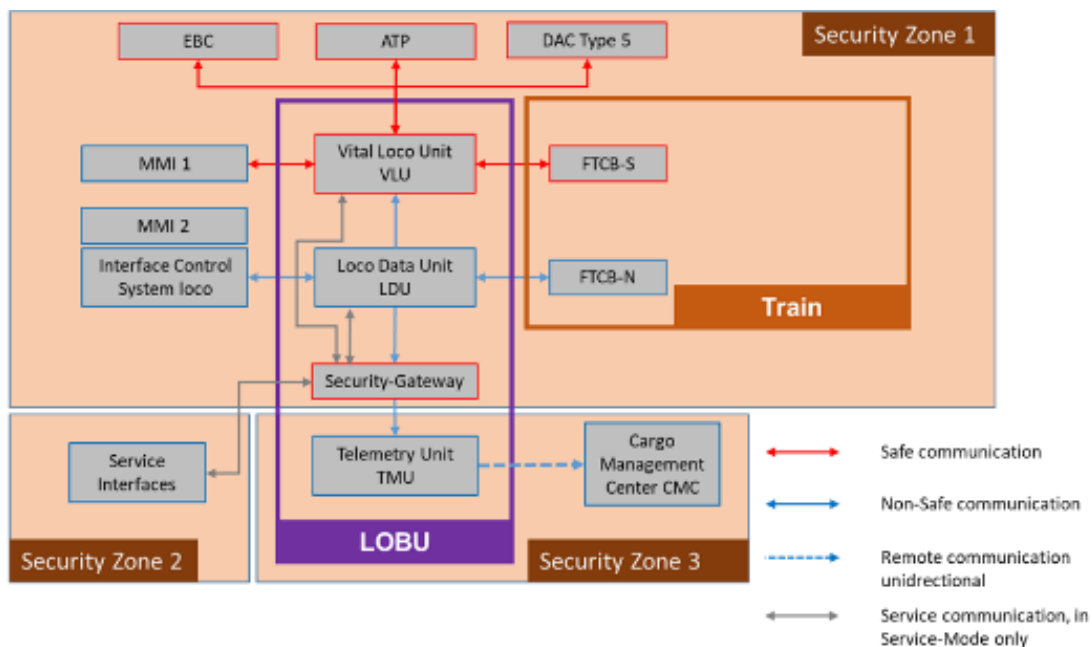

LOBU and architecture

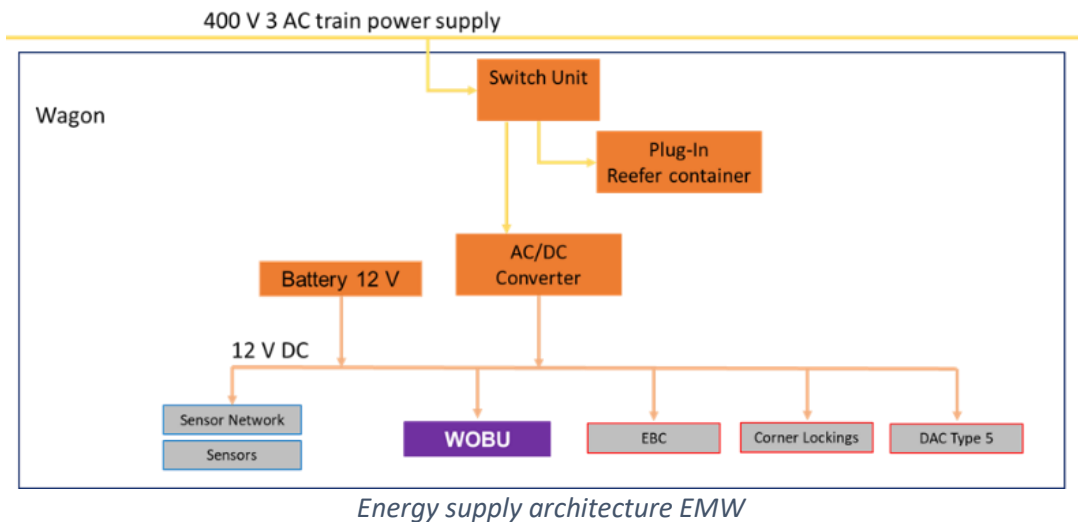

A number of subsystems and services have been developed and tested focusing on a generic intelligent freight wagon with a broad application scope, which could also be applied to the CMW and EMW. Among those, there are:

- Wagon Monitoring
- On-board Positioning
- Freight Train Wireless Communication
- Power Harvester
- Brake Monitoring
- Wayside Monitoring

The activities related to the axle power harvester have continued with the definition of the test protocol and the laboratory tests of the first version of the system. The results of these tests showed that a redesign was required, therefore a second version of the axle mounted power harvester has been completed, from the redesign to the manufacturing and the first test has been covered.

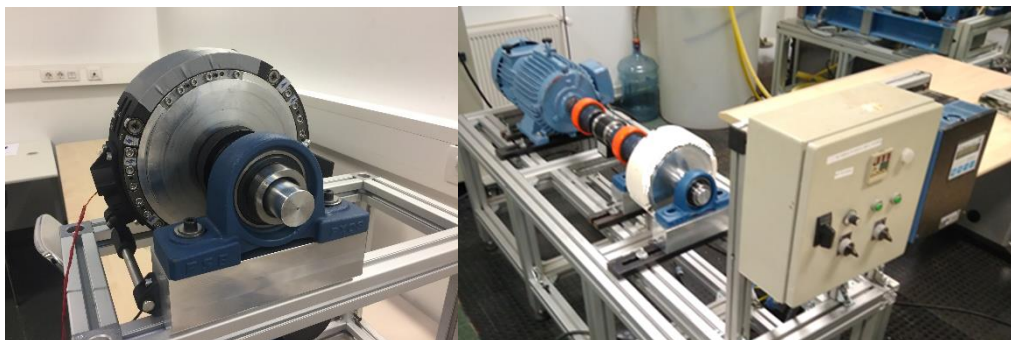

Axle mounted power harvester testing lab. setup

Field test to assess the behaviour of wireless communication technologies in a freight train has been carried out in Sweden. LoRa and HOP networking for 802.15.4 in real train environment in static and dynamic conditions with 12 wagons (170 meters long).



Telematic box on the wagon and filed test team in Sweden

For TD 5.3, 2021 was a year heavily impacted by Covid-19. The pandemic-related restrictions not only meant limited field test trials and lab test availability but also came with supply chain congestion and the reduction of working hours. Nevertheless, project is back to delivering progress, and key milestones have taken place, such as triggering the manufacturing of EMW Wagon. After a rescheduling exercise the TD is back on track and expected end dates for the EMW and CMW TDs are now set in Q2 2023.

TD5.3 Smart Freight Wagon Concepts									
2015	2016	2017	2018	2019	2020	2021	2022	2023	...
		Finished: FR8RAIL, INNOWAG, FR8HUB							
			Ongoing: FR8RAIL II, FR8RAIL III, FR8RAIL IV						

In 2021, 16 deliverables were planned out of which 6 were released. TD 5.3 has reported having accomplished 80% of the planned work up to the end of 2021, which represents around 60% of the overall TD.

TD5.4 New freight propulsion concepts

The target of this TD is to provide more attractive rail freight services to the final customer, with competitive rail solutions maximizing flexibility and efficiency while reducing the operating and maintenance costs. The focus of this TD is on improving the overall performance of today's locomotives by adding and integrating additional functionalities and technologies. Future locomotives will provide extreme flexibility for operation in non-electrified and in electrified lines, allowing private and public operators to offer broader rail freight services according to demand without the need of changing the locomotive or allowing the new production concepts. Future locomotives will feature remote control for distributed power, thus, allowing the increase of the train length up to 1500m and consequently improving the cost efficiency of rail transport. Moreover, other areas of work include reduced LCC, braking energy recuperation, operational efficiency increase by automating various activities such as train start-up, train preparation, start of mission, stabling and parking, generally shunting.

TD progress

In 2021 this TD built on the progress made with the member call projects FR8HUB, FR8RAIL II and FR8RAIL III which took onboard the work delivered by the already finished projects FFL4E, M2O and DYNAPFREIGHT. Due to Covid-19, Last Mile Battery activities have been delayed by half a year.

The main achievements for 2021 were (1) the demonstrator of the distributed power system (DPS – Long Trains) technology which allows to pull heavier and longer trains, (2) the progress in the development of the last mile battery in lab environment to be demonstrated in a locomotive by Q1

2022, and (3) the development of a powerful traction battery including the battery management system for the hybridization of freight locomotives and new concepts for the auxiliary converters.

The “Long Train” activity not only developed the technology and demonstrated it, it also backed up the related business case with data coming from commercial service. The picture below shows the effect of longer trains on a specific line. It is evident, that DPS allows to increase both the length and the weight of the trains. Later ones are the low hanging fruits as the implementation does not require the adaption of the infrastructure allowing today in most European countries train lengths of max 740-750m only.

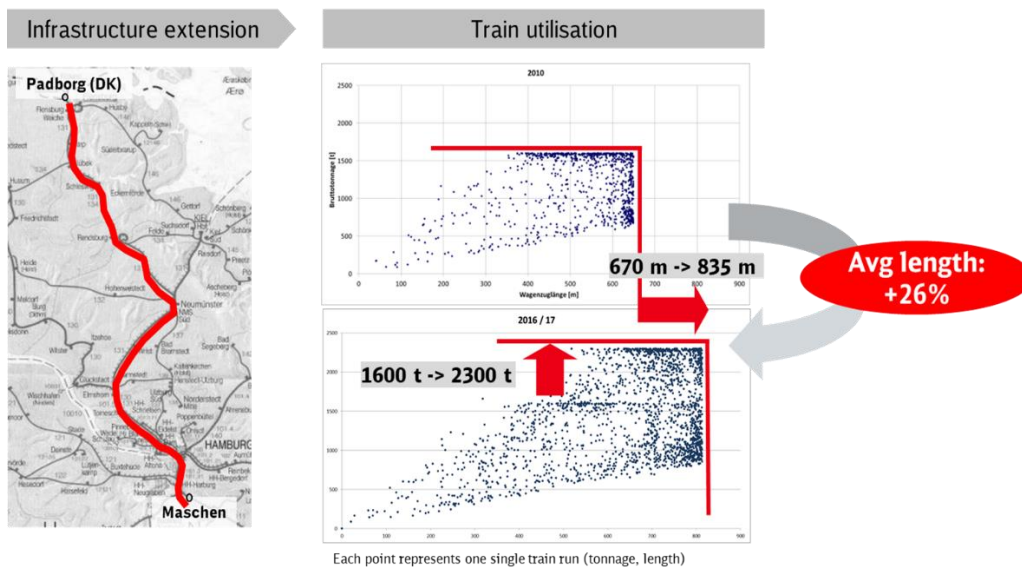

In February 2021 the DPS technology was successfully demonstrated during several days on a commercial train. In this case, various trains with single wagon load (mixed wagon) run on the Frankenwaldrampe (Germany’s track with the highest gradient = 27‰) using three locomotives (one in the front, one in the middle and one at the end of the train) of two different types. In April 2021, 835m trains run between Maschen and Fredericia.

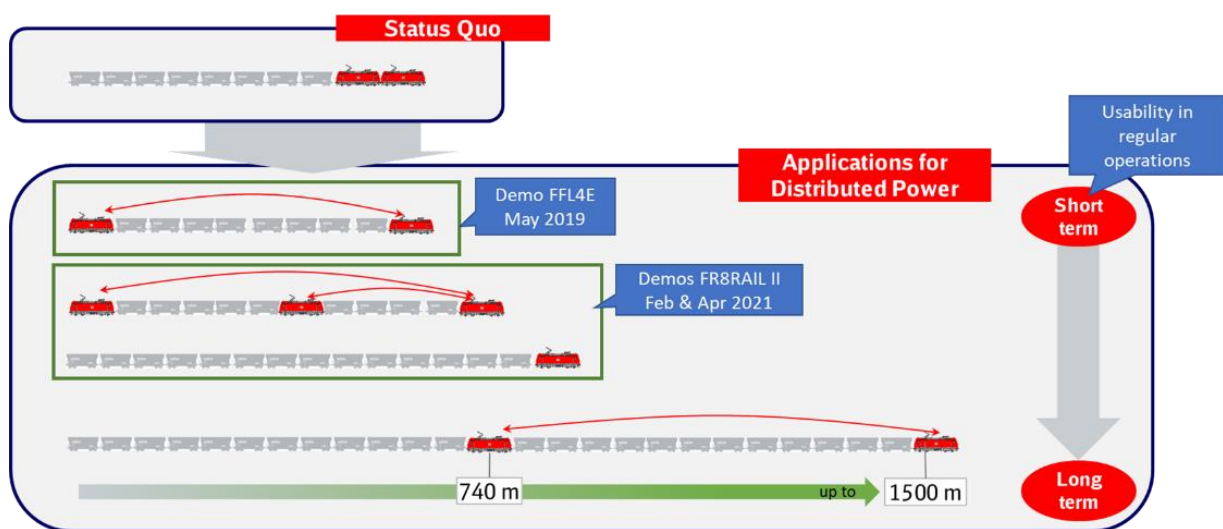

The takeaways were: The radio coverage was better than expected, the DPS functions worked as expected, the release times after brake application were much shorter than today and the measured

in-train-forces were in the range or lower than simulated. These results are very promising and a good start for the steps to be done in the follow-up project FR8RAIL IV.

In the area of last mile, the TD has done an analysis of various energy sources for last mile application, looking at different diesel engines, fuel cells, batteries, flywheels, etc., concluding that a diesel engine still offers the best energy density vs cost ratio, although it is not so good with regard to the CO₂ footprint. Within this framework, the most efficient and future-oriented approach is definitively a large battery. During 2021, relying on the results achieved in FFL4E, a new water-cooled LI-Ion based last mile battery has been designed.

In the area of last mile, the TD has continued the development of the 800V 105kWh battery with a dedicated DC/DC converter, a thermal conditioning unit, all integrated in a cubicle which today houses a last mile diesel propulsion engine. The system is ready for the integration of another 105kWh (which were not considered in the project due to limited budget). The full system with 210kWh will provide enough power (in the range of several hundred kW) to pull heavy freight trains on their last mile, depending on how the battery blocks are connected together. The concept for an innovative mission manager for last mile application has been finalized with a report.

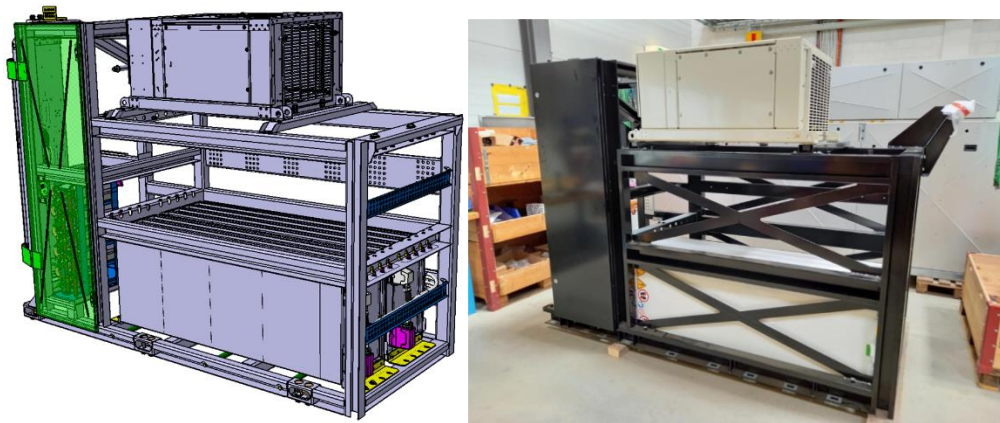

In 2022 new design concepts around auxiliary power converters, such as for instance medium frequency converters, are studied. These converters may make use of new switching technologies that will enable a significant reduction of the weight and therefore a great reduction on energy consumption. First results are expected in mid-2021.

The work on power peak shaving has been finalized in 2021 showing that by introducing larger energy storage systems, such as for instance also a last mile battery, power peaks can be reduced effectively. Implementation to a full extend, over a complete fleet of train, may help to reduce complexity and costs on the infrastructure side.

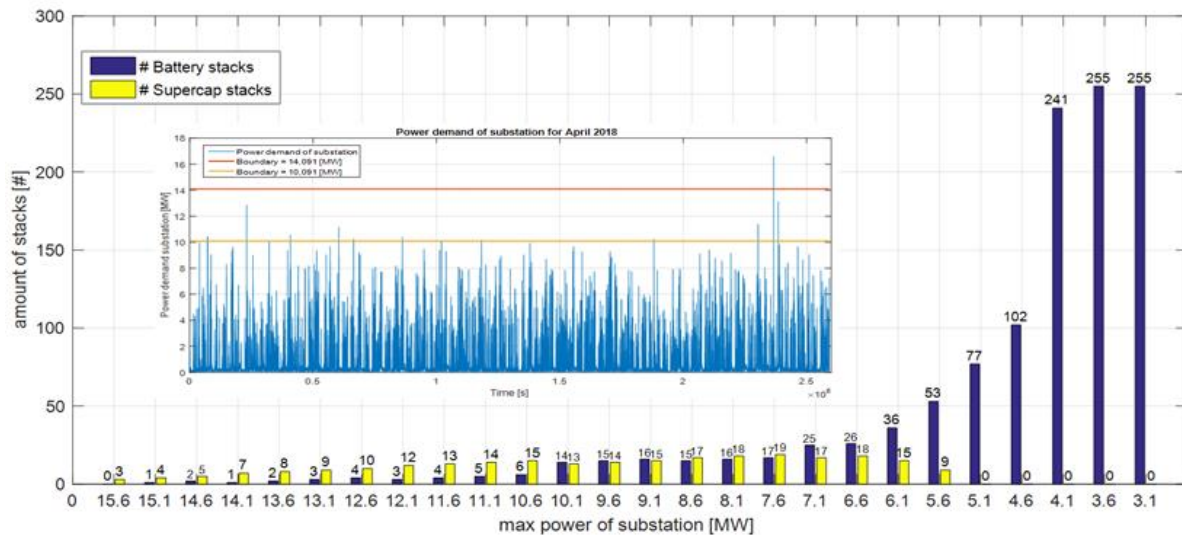

TD5.4 New Freight Propulsion Concepts									
2015	2016	2017	2018	2019	2020	2021	2022	2023	...
		Finished: FFL4E, DYNAFREIGHT, FR8HUB, M20, FR8RAIL							
			Ongoing: FR8RAIL II, FR8RAIL III, FR8RAIL IV						

In 2021, 24 deliverables were planned out of which 16 were released. TD 5.4 has reported having accomplished 77% of the planned work up to the end of 2021, which represents around 65% of the overall TD.

TD5.5 Business analytics and implementation strategies

This TD ensures that IP5 develops technologies in line with the market needs and with sound plans for introductions into the market. This is provided by migration plans for implementing new technology solutions on a large scale, identifying market segments and developing specifications and Key Performance Indicators for freight.

TD progress

This TD has come to an end by 2021. TD 5.5 contributed to works in areas of market segments identification, development of (high-level) specifications and key performance indicators (KPIs), and in the area of migration plans.

Already in 2018 the goal of TD 5.5 was to establish KPIs for freight and for that, cooperation has taken place with the CCA IMPACT II project and top-level requirements have been one target to reach. The work on market segments and top-level requirements for wagon applications have had a central position in the TD 5.5 whereas the first deliverable was finished in late 2018.

The year 2021 was very important for this TD (although with no physical demonstrator) as it meant the delivery of the migration plan for IP5, plus the key scorecard metrics to measure the desired improvement within all stakeholders (customer included). The research concluded that the development and implementation of new technologies alone will not be enough to attract additional transport to rail. It will be imperative to change the way services are provided. Contrary to what is often assumed by the sector representatives, the low competitiveness of rail is not due to too high costs and thus too high offer prices. It is rather that today's service offer does not meet the expectations of a transparent, flexible and easy-to-integrate transport task. Lack of accessibility to and reliability of the overall system result in poor service quality of rail.

The study/migration identifies different business models, current and future ones, being very innovative for High Value low volume freight market. The segmentation of the market and the different models are met in IP5 by means of an evolutionary approach (common market wagon CMW R&I line) plus the revolutionary approach (served by the Extended Market Wagon). Both lines at a different level of maturity will develop “runnable” demonstrators by the end of 2022.

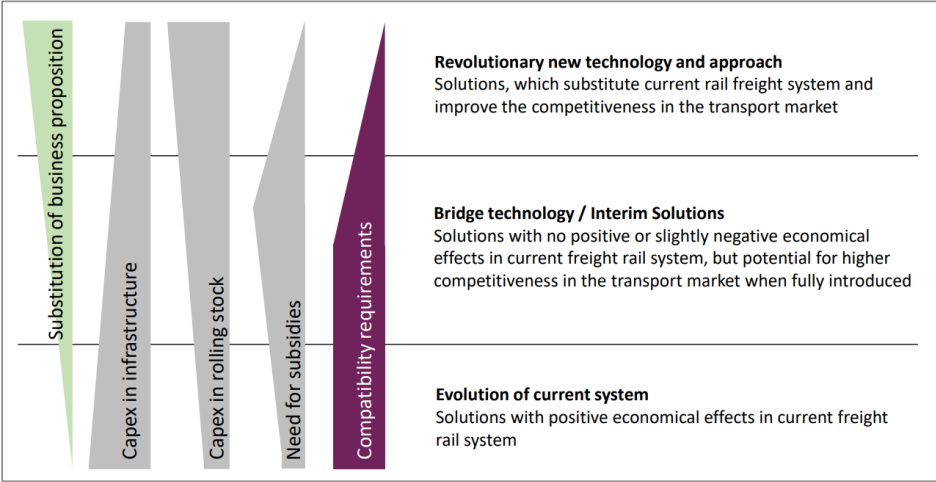

The TD works in areas of identification of market segments, development of specifications and key performance indicators (KPIs). By means of the IP5 solutions the LCC for freight, measured in €/t/km, can be reduced by about 35% across all operational modes if all innovations are implemented in the market. This reduction of LCC is mainly driven by:

- Improved utilisation of rolling stock material (locos and wagons (km/a)) due to reduced transport process time in the terminals, yards and on the main line (prerequisites: IVG, wagon electrification, automatic coupling, real time yard and network management),
- Increased pay load due to reduced wagon tare weight,
- Automatic train operation on main line,
- Improved loading factor due to digitalisation of processes.

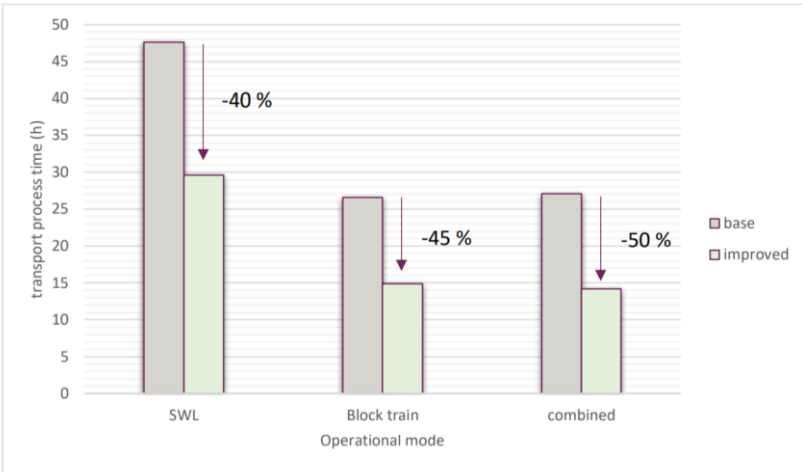

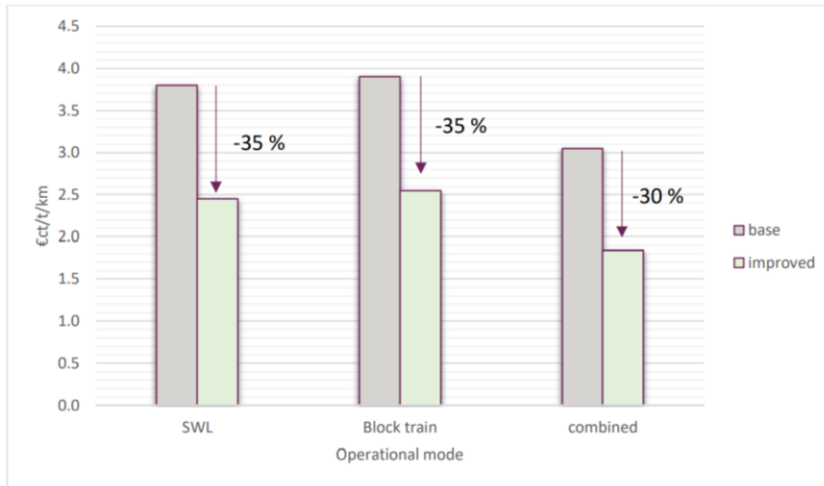

IP5 Potential Improvements LCC (€/t/km) and transport process time

Finally, the TD 5.5 finishes its journey within IP5 by delivering a tentative migration strategy with a draft schedule from 2025 to 2050, setting priorities and making a cost-benefit analysis on the innovation delivery pace.

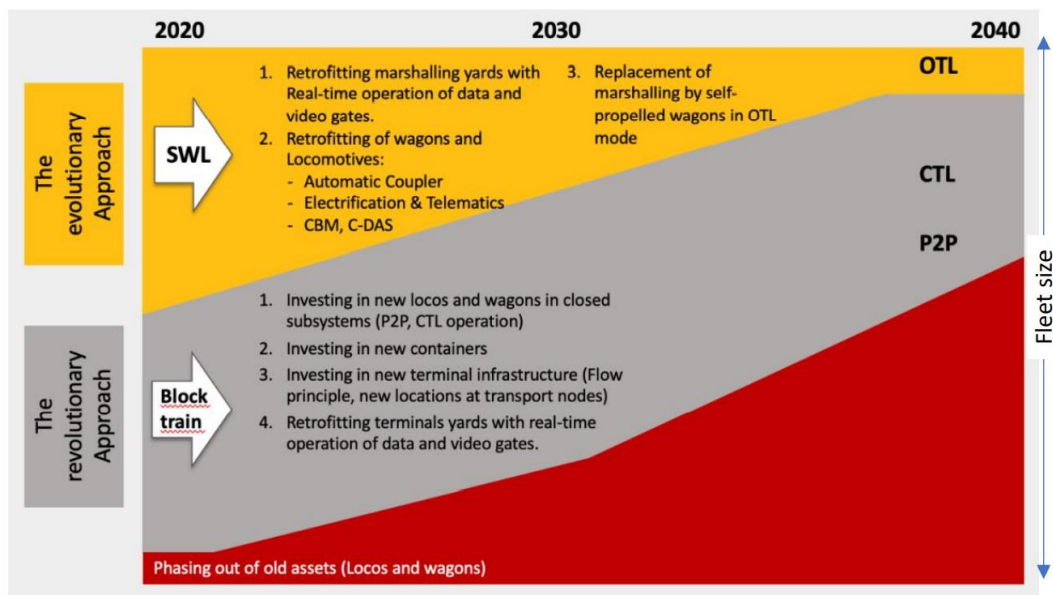

Market uptake: Transformation of the rail freight system along a “process of displacement”

TD5.5 Business Analytics and Implementation Strategies									
2015	2016	2017	2018	2019	2020	2021	2022	2023	...
		Finished: SMART-RAIL, FR8RAIL, INNOWAG, FR8HUB							

In 2021, 2 deliverables were planned out of which 2 were released. TD 5.5 has reported having accomplished 100% of the planned work up to the end of 2021, which represents around 100% of the overall TD.

1.4.6. CCA Cross Cutting Activities

An overview of the various work areas in the CCAs is shown in the figure below.

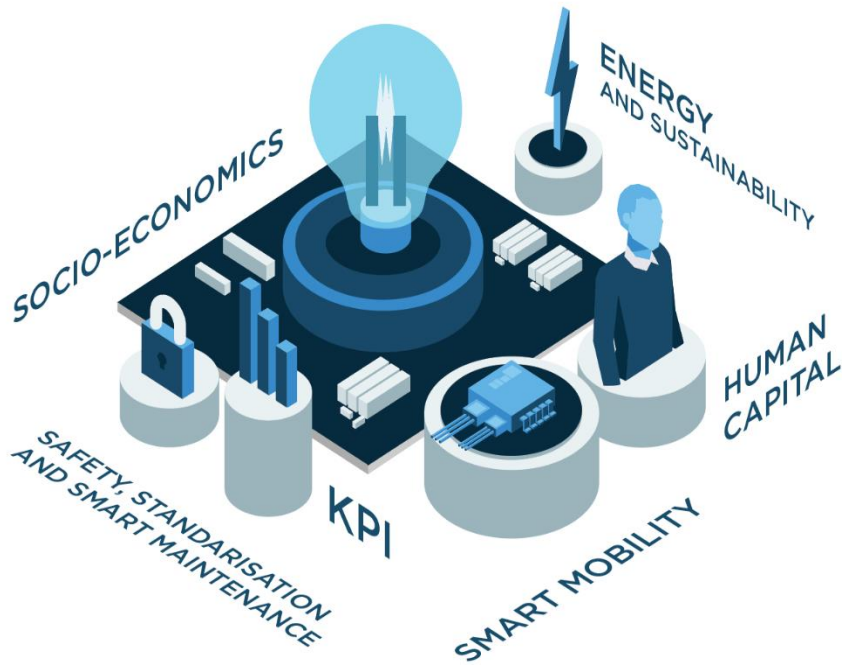

Cross Cutting Activities are relevant to the different subsystems of the five IPs taking into account the interactions between them.

These Cross Cutting Activities ensure that the R&I activities within the different Innovation Programmes are closely aligned in terms of their objectives and their requirements, as well as the methodologies for evaluation and assessment of impacts. The Cross Cutting Activities facilitate a coordinated approach in order to avoid duplication and guarantee consistency.

CCA work is organised so as to achieve the objectives in the following areas:

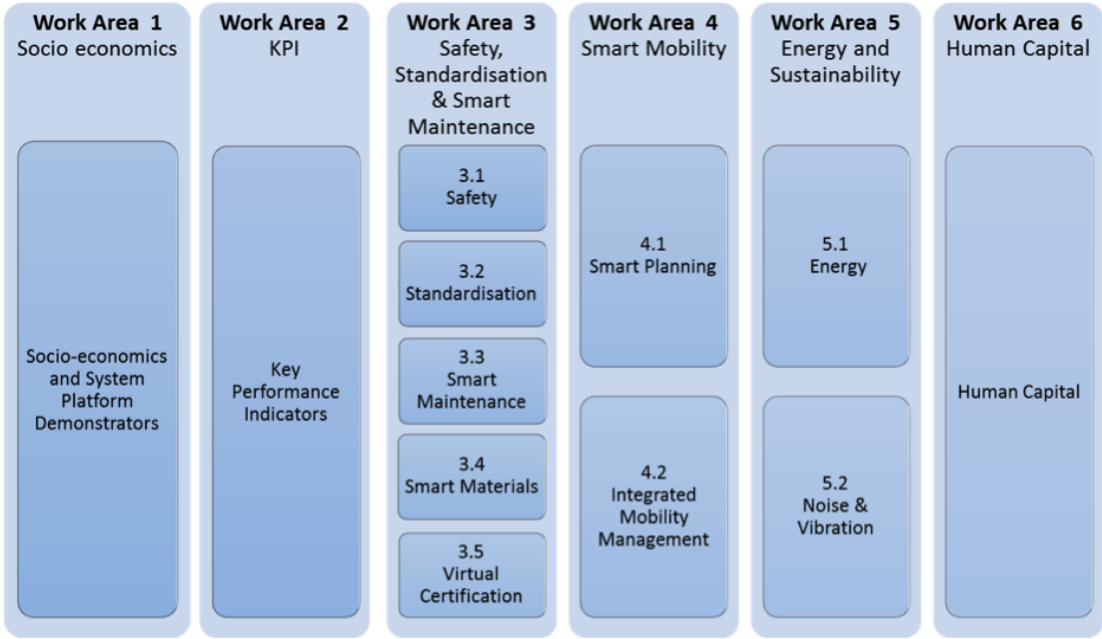

Below a summary of the activities performed in the CCA Work Areas (WA). Activities under WA 3.4 (Smart Materials) have not started; some activities on this subject will be carried out in the dedicated Innovation Programmes.

WA 1 - Long-term needs and socio-economic research

The objective of WA 1 is to analyse the areas and the expected improvements that the works deployed under S2R bring to the European context in terms of social and economic benefits.

The work area is addressed in the CFM projects IMPACT-1, IMPACT-2 and complemented by the OC project NEAR 2050 as well as the cost benefit analysis carried out in Task 3 of the tender on “Strategic support to the S2R Joint Undertaking”. In October 2021, the Ben@rail project was launched.

In 2021, work on identifying and calculating the benefits of S2R for the society was finalised. The social benefits have been calculated for four use cases including passenger rail corridors for high-speed, regional, and metro, as well as a rail freight network. The social benefit calculations build on the results of the modal shift calculations. The social benefits are in the form of aggregate consumer and producer surpluses, the net of changes in external effects (safety, environmental effects etc.), and wider economic benefits/agglomeration effects. Changes in external effects have been calculated with and without assuming congested roads, which has a large effect on the social benefits of externality reductions, which are higher if it is assumed that roads are congested. The results described in IMPACT-2 D2.3, show that there are large positive social benefits of the S2R innovation improvements for the high speed and regional use cases as well as for the freight case. The positive effects on total benefits from (reductions of) total externalities are larger in relative terms from introducing S2R innovations in the regional rail SPD than in the high-speed SPD. Frequently above 25% of total benefits while for HS it’s 10%. For the freight scenario, with the EU valuation, the environmental benefits are 216 million Euros per year for when S2R is introduced in baseline and 230 million Euros when S2R is introduced in the electrified scenario.

Social benefits have also been calculated for alternative future scenarios considering innovations also in the road sector such as electric (EV) or automated (AV) cars and trucks. Another positive aspect discovered is that the introduction of the S2R innovations would allow for rail to retain market shares even in the event of the increased use of EVs or AVs, in particular increasing societal benefits in particular in the high-speed and regional use cases.

During 2021, the modal shift models for the system platform demonstrators (SPDs) progressed with the completion of the implementation of the modal shift models for high-speed passenger rail, regional passenger rail, metro, and rail freight. The work also incorporated recommendations following from a review of the model by the European Passengers Federation. The effects of S2R innovations have also been tested within four complementary future scenarios same as the ones for the societal benefits that include improvements in the road mode, i.e., moderate/optimistic electrification/automation of cars and trucks. The conclusions of the exercise described in IMPACT-2 D3.3 show that S2R innovations seem to have a large potential to increase the rail modal share, especially for high-speed (baseline 24%; S2R scenario 35%) and regional (baseline 18%; S2R scenario 29-40%). The benefits for the metro system are more modest (1% increase compared to the baseline), mainly due to the fact that in the considered use case it is not possible to increase train frequency. In case of the freight case, a different modelling approach was used, here the market share increase is going from 21% (baseline) to 32-47%, depending on the scenario selected. As already mentioned for the societal benefit, the introduction of the S2R innovations will enable the rail to regain its market share against road innovations. In addition, the deployment path of the S2R technologies can also impact the modal shift results.

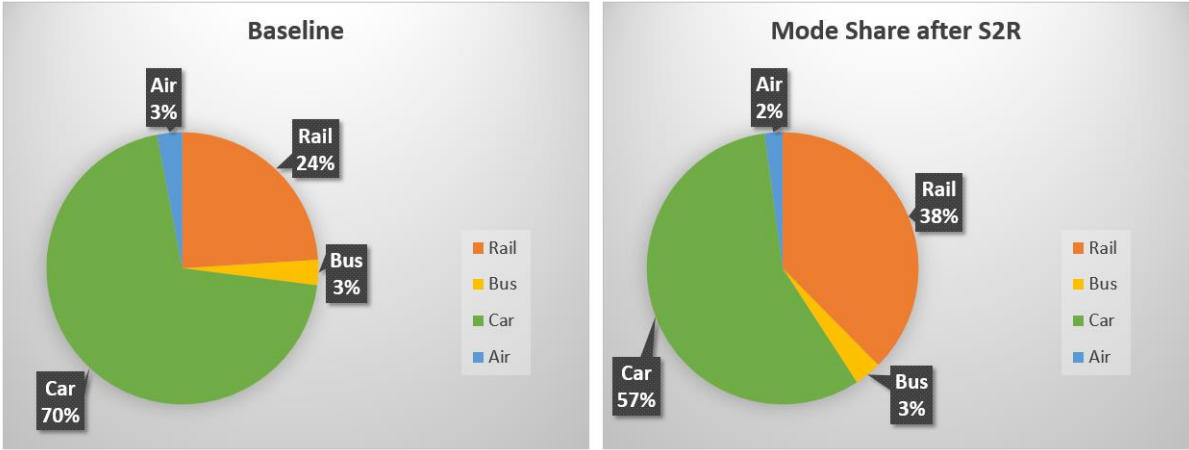

Table: High Speed Rail Use Case

Furthermore, in WA1 the improvement of the future railway system is described, when all S2R innovations are implemented. The document is especially addressed to railway undertakings and infrastructure manager for their investment decision in new technologies to get a benefit for their business. The document explains a potential migration plan for the technologies considering the following criteria: TRL, interdependency with other innovations, refurbishment option, lifetime of the asset. The document is still under internal review and will be published in the first half of 2022.

The Ben@Rail project was launched on the 1st of October with the objective to strengthen the effectiveness of EU-funded R&I activities in the railway research domain amongst the rail sector stakeholders, in order to ensure a tight adherence of the innovations stemming from Europe’s Rail Joint Undertaking to the needs of railway stakeholders and final users.

WA1 Long-term needs and socio-economic research & SPD's									
2015	2016	2017	2018	2019	2020	2021	2022	2023	...
		Finished: IMPACT-1, NEAR2050							
				Ongoing: IMPACT- 2, Ben@Rail					
						AWP 2020: Tender			

In 2021, four deliverables were planned and two deliverables have been released, the remaining two deliverables will be submitted with slight delays in 2022. Due to the launch of the Ben@Rail project, the status of the WA is amended. WA1 has reported having accomplished 90% of the planned work up to the end of 2021. The current work represents 80% of the overall WA.

WA 2 – KPI (Key Performance Indicators) method development and integrated assessment

The objectives of the Work Area 2 are to capture the impacts of the TDs and to assess how they contribute to the key S2R targets by defining and quantifying key performance indicators for their results.

These objectives of this Work Area are achieved through the following projects:

- CFM-Projects IMPACT-1, IMPACT-2,
- Long-term needs tender focused on the support for KPIs development.

The main objective for 2021 was to conduct the KPI model validation process through in-depth reviews of the KPI model with the Innovation Programs (IPs) in order to achieve a better understanding of the KPI calculation for the different system platform demonstrators (SPDs). Furthermore, the collection of the accuracy level was achieved to ensure coherent results of the KPI model based on the definition of the qualitative scales ranging from "level 1 - expert estimates" to "level 4 - physical prototype" for technical values or "level 4 - based on market" for cost values. By conducting in-depth reviews of the KPI model for all IPs and collecting updated improvement and accuracy level values from the TDs, a higher precision of the KPI results has been achieved: All parameters were fed into the model and an updated set of quantified values for the master plan targets "LCC", "Capacity" and "Punctuality" has been computed.

The cooperation and exchange process with the TDs were continued on the basis of the previous years' input to the KPI models. As part of the annual update 2021, performed from July to September 2021, the TDs had the opportunity to submit updated improvement values and accuracy levels. The updated values from the annual update 2021 data collection result in Release 4 of the KPI Model which can be found in Annex C, Table IV of this Report.

The progress made in WA2 with regard to the KPI assessment in 2021 for the IPs is described below. Through the in-depth review of IP1 (Rolling Stock), open points such as fleet acquisition, coupling ability, energy and train capacity have been closed.

For IP2 (Command, Control and Signalling), a different modelling approach compared to the other subsystems, such as vehicles and infrastructure, was developed in 2020 and finalised during several review meetings in early 2021. Improvement values and accuracy level obtained during the review process for IP2 were finally included in the results of KPI Release 3.2 and were confirmed during the annual update of 2021.

Within IP3 (Infrastructure) an in-depth KPI model review was conducted during a workshop in November 2021 leading to a confirmation and validation of the KPI model calculation.

As part of the review process for IP5, the effects of longer freight trains were analysed and its outcome included in the KPI model.

The Customer Experience Model was finalised early 2021 capturing benefits from IP1 and IP3. The results of the customer experience model based on the updated improvement values coming from the annual update 2021 were considered.

WA2 KPI method and integrated assessment									
2015	2016	2017	2018	2019	2020	2021	2022	...	
Finished: Roll2Rail, IMPACT-1			Ongoing: Tender KPIs, IMPACT-2						

In 2021, the deliverable D4.6 was planned and has been submitted in June 2021. WA2 has reported having accomplished 94% of the planned work up to the end of 2021. The current work represents 90% of the overall WA.

WA 3 Safety, Standardisation and Smart Maintenance

Work Area 3 builds on the activities of the projects Plasa/Plasa 2, GoSAFE RAIL, IMPACT2 and SMaRTE. The graph below refers to all the activities performed in the whole WA. WA 3.4 (Smart Materials) has not been launched in the S2R Programme. The activities in Safety (WA3.1), Smart Maintenance (WA3.3) and Virtual certification (WA3.5) were completed in previous years. One work area remains active - that is the Standardisation.

WA3 Safety, Standardisation, Maintenance, Materials, Virtual Certification									
2015	2016	2017	2018	2019	2020	2021	2022	2023	...
Finished: PLASA, GoSAFE RAIL, SMaRTE, PLASA - 2					Ongoing: IMPACT- 2				

WA 3.2 – Standardisation

The main objective of WA 3.2 is to foster the transfer of S2R results and outcomes of innovation activities into standards or regulatory documents when needed and beneficial. It aims to provide a coordinated approach across the S2R research activities and to develop optimised pre-standardisation aligned processes with the relevant standardisation bodies, standard setting organisations, as well as ERA.

The Standardisation work area is covered in the IMPACT-2 CFM project, which started in September 2017.

In 2021, the investigation on standardisation potential of the S2R outcomes continued across the different projects, with a continuous improvement and refinement of the Standardisation Rolling Development Plan (SRDP), especially through dedicated and focused workshops involving the TD leaders. The updated information will be published in version 5 of the SRDP in the first quarter of 2022. Regular exchanges with the Commission, the European Railway Agency and with CEN and CENELEC railway TCs contributed to inform the standardisation and regulatory bodies about the expected standardisation outcomes and their feedback were captured in V5 of SRDP.

WA 3.2 continuously contributed to the RASCOP ad hoc group on Standardisation Request, by identifying and expressing the standardisation needs from the research results of the S2R Programme

for their future implementation in the market. It highlighted where and when some significant input can be expected from the research outcomes to revise or develop the standards supporting the next TSIs mainly related to the areas such as TCMS, Running Gear and accessibility.

A report “Guidelines for Standardisation” (IMPACT-2 D5.3), aiming at providing guidance on pre-standardisation processes coming from R&I for the emergence and development of standardisation proposals and for an efficient connection to the standardisation bodies were issued in December 2021, building on the experience of the work carried out in S2R. The deliverable also proposes tools and guidelines to future project leaders, to better integrate the standardisation issue in their research and development activity.

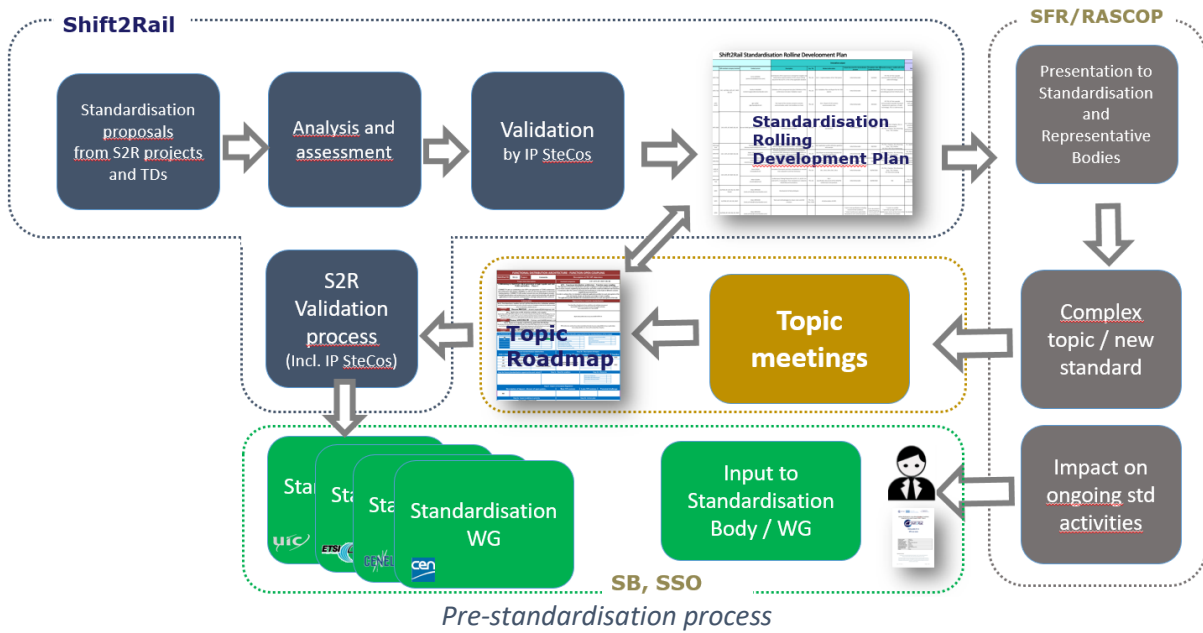

A work on detailing and contextualising the standardisation needs and proposals, aiming at describing how the S2R contributions to standardisation meets the sector’s needs and engagement in standardisation, started and will be continued in 2022. It is focusing on a selection of topics of major

importance for the sector and for their support of European Regulation. The draft report currently addresses items such as TCMS, DAC, noise, while other topics are also identified, such as the Virtual Validation and Conceptual Data Model. The work will be progressively enriched and published in 2022.

After a slowdown in 2020 due to a lack of resources and due to high workload related to the support of the European Commission in supporting the development of the Standardisation Request, additional resources were allocated to support this Work Area in 2021 allowing its further progress and catching up the delays cumulated in previous years.

One deliverable pending from 2020 was submitted in 2021. WA 3.3 has reported having accomplished 80% of the planned work up to the end of 2021. The current work represents around 75% of the overall WA.

Work Area 4 - SMART MOBILITY

Work Area 4 builds on the results of the Roll2Rail (LP). The Smart Planning (WA4.1) activities were covered in the projects Plasa, GoSAFE RAIL and Plasa-2. The work was concluded in 2021. Activities related to Integrated Mobility Management (I2M) work area are covered in IMPACT-2 and FINE 2. The activities on I2M in IMPACT-2 were concluded in 2021. The activities in FINE-2 are still ongoing.

WA4 Smart Planning, I2M									
2015	2016	2017	2018	2019	2020	2021	2022	2023	...
Finished: Roll2Rail, PLASA, GOSAFE RAIL, PLASA-2									
						Ongoing: IMPACT-2, FINE-2			

Work Area 4.2 – Integrated Mobility Management

WA4.2 aims to integrate the data exchange between Traffic Management Systems, Freight operations and Asset Management Services using a unified data exchange mechanism (the “Integration Layer” or IL) to develop new business service applications.

In 2021, WA 4.2 finalized all its activities within IMPACT-2 and built on the work of the FINE-2 project.

The Work Area delivered the functional and non-functional requirements for Freight services to leverage on the specified advanced applications which are to be implemented into Traffic Management systems.

The key achievement in 2021 was the development of 11 prototypes from TRL3 up to TRL5 demonstrating and validating the specified applications and processes for freight related Traffic Management applications.

Demonstrator Description (GA)
Data exchange between TMS and Freight Operation TRL3
TRL3/4 Dangerous Goods Management application TRL3/4
ATO-application for industrial Freight trains TRL3/4
ETA calculation, slot planning/management and real-time freight monitoring/ customer information TRL3/4
Conflict Detection & Resolution TRL3/4
Rolling Stock and Crew Management TRL5
Annual and ad-hoc timetable planning TRL3/4
Automatic Routing application at depots/stations TRL3
Functionalities/esource mapping for Dangerous Goods Management TRL3/4
Container Management Systems Data Optimization TRL5
Concepts for selected strategies for annual and ad-hoc time-table planning for freight operations service.
Analysis of operational rules oriented to optimization of freight traffic using high speed lines networks.

12M Demonstrators developed within IMPACT-2

The test results of the prototypes have validated the concepts of the new functionalities addressing improved timetable planning and execution, increased process automation and a higher level of usage of theoretical line capacity. These new designed business applications enable a step change in Rail Freight Transportation.

To standardize the data exchange between different software modules, Application Programming Interfaces (APIs) in different programming languages (REST-, STOMP-, JAVA- and C-API) including a set of commands, functions, protocols and objects needed for the access to the communication platform, have been specified. Together with the Integration Layer, the communication Network, and the Platform specific Data Model, these interfaces complete a new solution for an integrated interoperable Communication Infrastructure.

A TMS platform specific data structure (PSM) for both freight and passenger transportation has been designed with special focus on such as asset status with specific data elements for infrastructure and rolling stock, Freight type and Asset-Status and transported goods. The integration into the data model was developed in close cooperation with TD2.9 and become a key source model for the Platform independent Data Model.

The interface for Conflict Management applications has reached TRL3 and will be upgraded to TRL4 in 2022. The API TRL3/4 for data exchange between Freight related Traffic Management software modules has reached a level of 65 % completeness and the design of the Interfaces TRL3/4 to integrate Hazardous Goods Management into the overall TMS process have been finished. The final testing and integration of these prototypes will be part of activities in 2022.

Predefined use cases and interface specifications were expanded, and series of Initial proofs-of-concept (POC) were developed. The team successfully developed three initial POCs, looking at areas such as the interface between weather and TMS, to understand the feasibility of automatically applying and removing Temporary Speed Restrictions (TSRs) to reduce disruptions to customers; as

well as improving the responsiveness to such disruptions by enhancing passenger information or integrating information to assist operators.

In 2021, three deliverables were planned and all have been submitted in I2M subarea. WA 4.2 has reported having accomplished 100% of the planned work up to the end of 2021. The current work represents 60% of the overall WA.

Work Area 5 - Energy and Sustainability

Work Area 5 builds on the results of the ROLL2RAIL (LP). Relevant activities were completed in the projects FINE 1, OPEUS and DESTINATE. Activities on these areas are ongoing in the projects FINE-2, TRANSIT and SILVARSTAR.

WA5 Energy and sustainability								
2015	2016	2017	2018	2019	2020	2021	2022	...
Finished: Roll2Rail, DESTINATE, FINE 1, OPEUS				Ongoing: FINE-2, TRANSIT, SILVARSTAR				

WA 5.1 - Energy

The overall objective of this work area is to develop a standardised methodology for estimation of energy consumption by simulation and measurement enabling the standardised specification of energy efficient railway systems.

The Energy work area is covered in one ongoing member’s project FINE-2, launched in December 2019.

With regards to the S2R energy labelling proposal, a questionnaire was finalised for railway stakeholders with the objective to gain an impression of stakeholders’ experience and opinion on proposed scope of energy labelling of rolling stock and beyond (environmental impact label). This questionnaire addresses rail stakeholders such as manufacturers, purchasers, operators, transport authorities, infrastructure managers and local administrations. The questionnaire was circulated to sector organisations as well as to the JU members.

The collection of the answers was carried out in 2021 and the analysis of the answers will be concluded in the beginning of 2022.

In 2021, the sub-level KPIs of Technical Demonstrators and System Platform Demonstrators have been collected and an estimation of energy baseline have been issued to update the energy KPIs per rolling stock segment (high-speed, regional, metro and freight). The calculation of energy KPIs have been done with OPEUS software. The result fed into the S2R KPI activity within WA2.

The final verification and validation of energy KPIs improvement will be made in 2022.

Some specific technologies for mainly urban scenario were selected which can have substantial energy reduction potential. The following works were carried out to compare real measurement against theoretical estimations:

- The validation of a Thermal car body model used for HVAC was carried out and successfully concluded based on comparison of results of real measurement campaign with a high-speed train.

- Activities related to assessment of energy savings by new concepts and smart control of auxiliary loads and HVAC systems were carried out. On metro application, annual auxiliary energy consumption can be reduced by 21%.
- DAS implementation by real measurements (FINE-2 D5.3) shows that comparison of the energy consumption of the manual operation modes against the energy consumption with the DAS on application case Tram Oslo. It was measured that improvement value can be 12-15%. In addition, the evaluation of real operation speed profiles and identification of possible optimisation potential is calculated on Metro Eukostren and gave improvement of 18-27%.
- Tunnel resistance estimation (FINE-2 D5.2) was carried out on an urban application. Tests took place at Eukostren demonstrators in open field and tunnels of different characteristics. Two different methodologies coupled with simulation tools have been analysed. As a conclusion, the coasting method as applied in open field is not suitable in tunnel. As shown by the OPEUS simulations, the impact of the running resistance on the energy consumption is low in metro-type operation. This assessment is concluded in FINE-2 however, it is suggested that any further analysis on the running resistance topic, either in open field or inside the tunnel, should be carried out on vehicles that run at 200 km/h or more.

During 2021, 8 deliverables were planned, and 4 deliverables submitted. The activities on the area of energy baseline and energy label are lagging behind subject to availability of resources and depending on input from external stakeholders. WA5.1 has reported having accomplished 80% of the planned work up to the end of 2021. The current work represents 80% of the overall WA.

WA 5.2 – Noise and Vibration

The overall objective of this work area is to reduce the annoyance and exposure to noise and vibration (N&V) related to the railway sector in Europe and to provide the necessary system approach and leverage the results from all the IPs by applying effective noise control in the different technical demonstrators. The N&V work area further supports the development of simulation methodologies for exterior noise at standstill and pass-by, based on existing tools stemming from ongoing and past projects, as well as the prediction of ground-vibrations by passing trains. The outcomes will further improve the acoustic certification process for new trains e.g. during authorisation as well for impact studies on vibration prediction during the Environmental Impact Assessment for new or upgrading railway lines.

The Noise and Vibration work area was covered in the previous CFM project FINE 1 and in the OC project DESTINATE, which were accomplished in 2019. Currently, there are 3 ongoing projects, the FINE 2 member's project, and two complementary OC-projects TRANSIT and SILVARSTAR.

The activities of this work area are massively hampered by the delays in measurement campaigns mainly due to Covid-19 but also due to the (un)availability of suitable trains. Different test campaigns had been planned to check the previously identified separation innovative techniques. Nevertheless, progress is made in developing source separation methods and algorithms based on simulation models, synthetic data, and experimental data from previous projects.

For the **exterior noise tools**, progress has been achieved in 2021. A first check of the measured data according to the in-house software tools of the involved partners (manufactures as well railway undertakings) was performed and showed a partially very good correlation between the simulations and the measured data. The train equipment will be measured standalone outside the train and again when installed on the train. On site tests have already begun, with a successful campaign taking place in Crespin, France during summer 2021. The activities were heavily impacted by the Covid-19 pandemic and the other planned tests had to be postponed to 2022.

Regarding **noise sources separation**, the work progressed on the development of innovative techniques to separate the noise sources of the train from other external noise sources (for example, the noise emitted by the rail) during the passing of a train at a constant speed. The objective is to use these separation techniques for the pass-by certification test as a partly virtual certification in contrast to the extensive and costly field measurements of today.

For innovative noise separation techniques, the three proposed methods (Advanced Transfer Path Analysis (ATPA), Pass-by Analysis (PBA), and TWINS-based transfer functions) were subjected to an in-depth SWOT analysis which will be completed in 2022 after the measurements have been carried out. Three site tests planned for this activity are postponed due to the COVID pandemic. A promising result regarding the separation of vehicle and track noise is that the car body has little effect on the transfer functions from track to reference microphones, for both the PBA and the ATPA methods. This is found in simulations and will be validated by measurement campaigns.

With regard to the **ground vibration prediction tool**, the goal is the development and validation of a hybrid approach, combining numerical prediction with experimental results. The requirements specification was accomplished and the collection of models describing the influence on vehicles, tracks, and soils on the vibration emission was completed. The challenge here is to combine scientific findings with existing prediction models for the subsystems involved to make an easy-to-use software whilst ensuring these are open enough to incorporate missing parameters or special local characteristics as discovered or modelled. By combining experimental data with numerical predictions, this hybrid approach provides much more flexibility and applicability than purely experimental models.

The software development has started and the first version of the ground vibration prediction tool was assessed together with the complementary project.

Furthermore, in 2021, work on the advancement of the tools for **auralisation & visualization** started. The simulation scenarios, input parameters, and software interfaces have been defined completed with a concept of validation. Specific data formats are still under development. The software interface between the auralisation and the VR application was established. An initial model improvement on rolling noise synthesis was achieved regarding the track contribution.

Following from the conclusion of the feasibility study of **new concepts and approaches on innovative materials and design tools** for improved interior sound control and acoustic comfort for passengers, two sources were selected: the UTLF (Ultra-thin low-frequency resonator) arrays for noise reduction in HVAC systems and the light-weight horn cover design. It was now optimized for the system conditions and the prototypes for tests are being designed. Also for the horn cover design, the optimization for the system specifications is ongoing to be implemented within the next step.

By 2021, 14 deliverables were planned, and 7 deliverables have been released, the other deliverables were impacted by the Covid-19 pandemic. WA 5.2 has reported having accomplished 70% of the planned work up to the end of 2021. The current work represents 60% of the overall WA.

Work Area 6 - Human Capital

The objective of WA 6 is to analyse the impact of future innovations resulting from the S2R IPs on the human factor in the rail system. The requirements and future needs of the humans in the system need to be taken into account in order to fully benefit from the advances in technology, for the workforce, but also for railway customers. The focus of the investigation lies on the impact on railway staff while also considering the impact on the customer.

WA 6 is addressed in the CFM-project IMPACT-2, the OC project SMARTE and a specific tender on Human Capital. The activities were completed in 2021, the outcomes of this work are presented below.

WA6 Human Capital									
2015	2016	2017	2018	2019	2020	2021	2022	2023	...
		Finished: SMARTE							
		Ongoing: IMPACT- 2							
			Tender HC						

In 2021, the work on creating agile organisation was finalised and reported in IMPACT-2 D8.4. A qualitative investigation and assessment were carried out considering the creation of a crisis management team (CMT) to make the company more agile when handling incidents affecting the flow of passengers. Core findings revealed three key episodes from the creation of the CMT to its decline. For each of these phases, the analysis show how organizational and professional logic can support or hinder each other. Finding and maintaining the balance between normal and agile organizations always appears to be delicate. The results question the relevance of integrating crisis management as a profession in railway organizations.

The work also provides some practical outcomes by comparing the agility of two models (professional group model vs. expert network model) in managing crises based on the following criteria: matching workload/workers availability, localisation, skills, link with the rest of the organisation as well as organisation and perennial. The assessment answers to the objective defined in the MAAP on feasibility and agile organisation. However, the results were mainly based on the experience of a single railway organization.

The other objective of this WA regarding the impact of S2R innovations on human capital was also concluded. The report also provides an overview of impact of S2R technology demonstrators and innovations/solutions on future jobs and skills profiles which considers the previous deliverables on this area. The final deliverable focuses on the TDs from IP2-IP5, as the work focused on those areas which were expected to have a fundamental impact on employment and jobs. The assessment was completed by a qualitative investigation on its importance with regards to the future composition of competence and staffing needed in the sector.

Due to the partner composition in this work-area, a more thorough analysis was carried out on infrastructure related works by the Swedish railway sector as for which detailed employment data was available. The extrapolation to EU level was challenging, it was mainly based on a workshop with other railways. Regarding the future development of skills and qualifications, results show that technologies developed in IP3 will have an overall impact at system level e.g. increased productivity enabled by improved long-term maintenance planning and operation rather than affecting specific professional roles.

During 2021, one deliverable was planned and submitted. WA 6 has reported having accomplished 100% of the planned work up to the end of 2021. The current work represents the overall objective of this WA.

1.4.7. IPx activities - Disruptive Innovation and Exploratory research

Artificial Intelligence (AI)

RAILS (Roadmaps for AI integration in the rail Sector) is a Ph.D. research project launched in December 2019. The project investigates aspects related to the adoption of Artificial Intelligence (AI) in rail

automation, predictive maintenance and defect detection, traffic planning, and capacity optimization. Based on the work conducted in 2020, the research carried out in 2021 aimed at:

- identifying needs, challenges, and opportunities for AI in railways;
- identifying current and potential application areas for AI across railway sub-domains;
- suggesting promising research directions;
- selecting AI techniques and methods against railway targets;
- identifying directions and approaches for transferability of existing AI applications developed in other sectors;
- providing preliminary recommendations for a fast pick-up of AI in railway transportation;
- promoting the adoption of AI among the railway stakeholders.

The following activities have been performed to reach the above objectives:

- Analysis of past and ongoing S2R projects and other European and overseas research projects in railway transportation, and review of the scientific literature. The objective of these activities was to assess the state-of-the-art of AI in railway and draw a mapping between AI techniques and railway subdomains. The results are reported in Deliverable D1.2.
- Survey among the railway stakeholders to identify challenges, milestones and current practices for AI in railways. The outcomes from the survey are reported in Deliverable D1.3.
- Synthesis of the review activities conducted in 2020 and 2021, bringing to the identification of relevant railway problems and application areas for AI techniques. The results of this activity are presented in Deliverable D1.3.
- Review of AI applications in other transport and non-transport sectors for transferability purposes, and preliminary definition of a structured approach to transferability analysis. Relevant directions include the transfer of: AI solutions from automotive (autonomous and cooperative driving) to the development of ATO systems with learning and adaptation capabilities and virtual coupling; AI-aided fault diagnosis and prognosis through Digital Twins and IoT from the machinery sector; AI-aided asset and bridge health monitoring based on autonomous UAV (Unmanned Aerial Vehicles) from the critical infrastructure sector. Transferability is addressed in Deliverables D2.1, D3.1 and D4.1.
- Identification of pilot case studies whose aim is to provide the context for the development of proof-of-concepts up to TRL3. In particular, the project in the next year will develop studies and proof-of concepts in Obstacle Detection and Collision Avoidance, cooperative driving for Virtual Coupling of Autonomous Train, Remaining Useful Life estimation and Health Monitoring, reduction of maintenance costs exploiting Digital Twins. The pilot case studies will be used as benchmarks to investigate trustworthiness and dependable issues related to the usage of Machine Learning techniques.

The project published scientific papers and articles. The project also organized in July 2021 the second edition of the AI4RAILS workshop series, whose first edition was held in 2020.

Autonomous Train Operation

In December 2020 activities around the autonomous train operation conducted by the IPX project TAURO were launched. Among them, two research areas have progressed significantly making first draft results already available.

Concerning the certification of perception systems (e.g. artificial vision, radar, lidar, ...) for Safety relevant functions such as lateral signals recognition or obstacle detection, the first steps have been completed. First, a comprehensive scouting process was performed to identify existing standards and

procedures (e.g. ISO 26262, IEC TR5469) that could be used in railways after an eventual required adaptation. Two aspects were considered: Artificial Intelligence and the Safety landscape.

In the second step, railway use cases were identified after analyzing and identifying the perception tasks and Artificial Intelligence perception functions. The last activity performed in 2021 was to start drafting the requirements of perception functions, including functional, architectural and environmental performance and RAMS requirements.

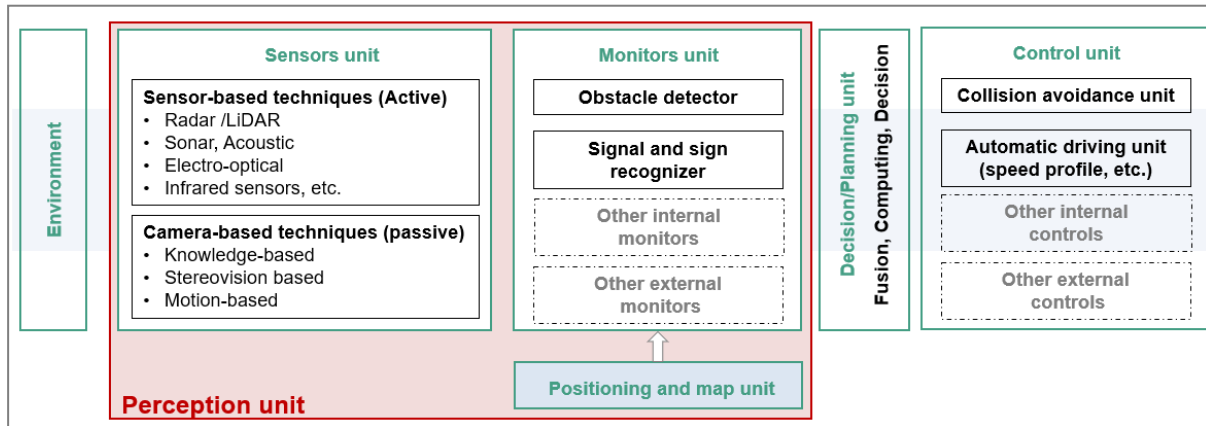

Figure 1: Perception planning control scheme for autonomous trains

The next step in this research area of TAURO will be to propose a certification procedure. This a complex task and requires additional expertise, for which the project has set up the advisory board in 2021. This group is composed of experts in the field of perception systems, Artificial Intelligence, certification, GDPR and other relevant subjects, coming from notified bodies, automotive TIER 1 suppliers, AI developers, ERA, final users etc.

The second research area of TAURO tackles remote driving and command functionalities. The activities in 2021 focused on the definition of the specification, which ended with a public deliverable. The process was also divided into three intermediate steps, very similar to the previous research area. The train goal is to prepare a specification to enable the remote driving and command for three relevant use cases identified by the Consortium: Remote driving under ETCS, in freight shunting yards and in depots for tramways.

First, a deep analysis of the functions which are suitable for their remote command was performed. This analysis was based on the actual driver tasks based on ERA_ERTMS_0155660 and the EN15380-4 Functional Breakdown Structure. For each function some parameters (including performance and safety concerns) were described.

In the second step, the three use cases were thoroughly defined using SysML, describing the actors, steps, and outcome, among other aspects. The main use cases were decomposed in smaller ones to facilitate the definition.

Finally, a large set of functional and non-functional requirements was identified.

Blockchain

Blockchains are a disruptive technology that have the potential to accelerate the development of rail as the primary medium-distance carrier within the wider multi-modal transportation system. Essentially functioning as electronic distributed ledgers, blockchains will allow the railway industry to

trace the exchange of assets between stakeholders, providing a non-volatile record of the transactions that doesn't require a single trusted authority to operate it.

The most obvious applications of blockchains within the railways centre on ticketing, but in practice the technology has the potential to impact many areas of the business. The B4CM (Blockchains as a Distributed Ledger for Attribution of Remote Condition Monitoring Data in Rail) project is providing funding for a PhD scholarship that is identifying key use cases for blockchain technology within the railways, developing a blockchain-based testbed that enables the benefits of the technology to be formally evaluated, and demonstrating the value of blockchains in the attribution of data costs from condition monitoring systems operating across organisational boundaries within the European rail sector.

Despite delays due to Covid-19 the project has progressed well in 2021, with two deliverable documents submitted, an initial version of the core framework based around Hyperledger Fabric developed, demonstration use cases in the process of being formalised, and the first of a series of journal papers documenting the findings of the team published.

In project deliverable D1.1 the team report on the B4CM project software framework, giving basic instructions for deployment and providing documentation enabling the usage, extension, and maintenance of a deployed system in the context for which it was developed. The project code has been made available via a public git repository, enabling users to easily access and extend the work for their needs, and can be accessed via GitHub (<https://github.com/B4CMProject/B4CMProjectSoftwareReleases>). The document begins by describing the software stack being used by the team, before looking in detail at each of the software constructs that form the blockchain network deployment of the framework. Finally, operation of the framework is demonstrated in a toy industry context based on the UK rail industry.

In deliverable D2.1 the team outlined the processes by which business / contractual exchanges may be captured and translated into smart contracts for use within the B4CM software framework, and to link these to the use of micropayment models for remuneration. The document begins with an overview of the background to the area, before moving into a more detailed discussion of arrangements for commercial access to data via the framework, and the accounting model to be applied.

In 2022, the project team will work towards a concrete demonstrator of the framework and accounting mechanisms operating under realistic industry scenarios. Two scenarios, both involving cross-interface monitoring systems with multiple industry stakeholders, were proposed in D2.1; the Unattended Overhead Monitoring System (UOMS) and rail bearing acoustic monitoring. These will be developed in detail in the first quarter of the year, before being implemented within the demonstrator over the summer period.

Copies of the deliverable documents and publications produced by the team to date are available via the project webpages at <https://www.b4cm.co.uk>.

Exploratory research

FLEX-RAIL is an IPX project dealing with exploratory research. It has a vision to target a lean, integrated, and flexible railway system, which will stimulate further innovation within the rail sector and will ensure that rail services can address the future user needs. The project is forecasting the evolution of key fundamental technologies, identifying technical risks and of potential blocking points, studying future user needs, formulating technological concepts of future rail system and will finally deliver recommendations and implications for the S2R activities. In the first phase, the project delivered a review of trends, transport sector innovations and blue-sky projects. This comprehensive inventory

of innovations and trends was made available in an interactive webpage (<http://flexrail.org/>). In 2020, FLEX-RAIL defined and prepared a dedicated framework used to assess the impact of the defined rail technology scenarios and transition pathways. It further worked on identifying gaps between future user needs, competitiveness requirements and technology potential with the status quo in the rail sector, including required paradigm shifts and the development of a future rail system scenario based on an open innovation participatory process involving general public and stakeholders was developed, to first decide which paradigms are holding back the rail sector.

In the second stage FLEX-RAIL generated new paradigm solutions for a future rail system. These paradigm solutions are defining draft scenario packages that have been evaluated within different perspectives leading to final scenario packages, describing the key functionalities, potentials and possibilities and alignments within the paradigm solutions.

In 2021 FLEX-RAIL was using this final scenario for detailed Impact Assessments of technology scenarios and transition pathways using the impact assessment model prepared in working packages before. These assessment results have been the basis for developments on the governance and business models for the future rail system. Final part of FLEX-RAIL was to submit a Report of recommendations for S2R activities related to S2R MAAP, defining recommendations to be addressed, in addition to the core plans already in the MAAP to achieve the Rail 2050 Vision and more.

Human-machine interface

The Translate4Rail (T4R) research project is tackling language barriers by advanced technologies and human-machine interfaces. The project started in December 2019. A set of comprehensive messages named as pre-defined messages (PDMs), which were taken as an input from the sector Language Programme and UIC XBorder project, were further enhanced and modified based on the communication needs between train drivers and traffic controllers at cross borders in a normal, degraded and emergency situations. The adaptation also included the changes to use the PDMs in the digital version for the T4R language tool prototype.

A language tool prototype was developed and tested in two Pilots in the border region of Austria and Italy. Making sure the level of safety will remain as it is today, B1 skilled drivers and traffic controllers have tested the prototype.

The tests showed that train drivers and traffic controllers are able to establish effective communication through PDMs by using a language tool. The results of pilots confirmed the importance of using PDMs, which are checked and validated by several operational and bilingual experts, as a safety critical element of the concept to reduce the requirement of language skills of drivers.

The ergonomic and user adoption aspects related to the human-machine interface were also assessed during the pilots. The train drivers and traffic controllers were interviewed regarding the user adoption aspects in the first pilot and dedicated tests and scenarios defined in the second pilot to assess the ergonomic aspects including different positioning of the tool in the cabin.

The project proved that the PDMs covers the communication between train driver and signaller for most situations during the international train operation using the language tool. The tool is able to work with PDMs manually selected and with voice recognition. The proper selected PDMs are correctly translated and in voice format further transmitted. The tool was also tested for free speech recognition including railway jargon where enhancement and development is recommended to continue.

New and emerging land mobility

HYPERNEX “Ignition of the European Hyperloop Ecosystem” was launched in December 2020, answering the topic on ‘Innovation in guided transport’. The project gathers a significant representation of European promoters and research centres, of technologies around hyperloop and together defining the enhanced / innovative modes in terms of concept of operations, safety cases, functional specifications, operational conditions and testing methodologies / environment and in addition also identifying the potential transferability and synergies with Railways solutions and other EU programmes, processes and procedures in general, and in particular from a technological perspective with the S2R innovations (Technology Demonstrators and IPX activities).

The final goal of this project is to offer a common framework for the development of the hyperloop ecosystem in Europe to all interested stakeholders.

In 2021, the project delivered the first technical outputs:

Observatory results (D2.1). This work identifies the stakeholders currently active in relation to the development of the hyperloop system in EU, including research and public organizations, private companies and public and private initiatives, along with stakeholders researching hyperloop as a side-project and test facilities and their characteristics. The document also examines the legislation in place and the available funding opportunities for the development of the hyperloop. Regarding legislation, an important conclusion is that, on one hand, until the main hyperloop challenges are defined, it is difficult to establish a hyperloop focused legislation, on the other, it is of most importance to have a regulatory framework as soon as possible to grant that the hyperloop developments fit the required legislation in matter of safety and to obtain the maximum compatibility, interoperability and intermodality. Main aspects to be considered include safety and security; international travel, including issues such as border crossings and fees for infrastructure exploitation; operations legal framework; interoperability and standardization; and evaluation of conformity, including certification. Going to the funding issue, one of the main findings is that the hyperloop endeavour cannot be financed by one sole party, so a public-private partnership should be the main approach.

Technical definitions (D3.1). The document summarizes the available technical information that allows depicting different scenarios that may arise during the start-up process of Hyperloop. This includes safety and operational visions considering what is possible to accept and adapt from rail knowledge, the common technical core, and challenges within an interoperability as a service concept, the identification of hazards, standardization roadmap and convergences with ongoing programs in other transport modes. In addition, concept of operation and standard operating procedures focused on the integration in control and management for service providers are tackled.

Due to delays related to changes in management of WP4 and due to summer holidays, the project partners requested a 3-month extension of the project. HYPERNEX will therefore last until February 2022 and deliver a Transferability and roadmap beyond HYPERNEX and organise a final event to present the project results.

Innovation in power supply

The aim of flexible medium voltage DC electric railway systems (MVDC-ERS) project is to propose a new type of MVDC traction power supply based on controlled bidirectional converters to increase the usage of the railway traction power supply network for the integration of renewable power sources and grid support. With reference to the on-board traction system, the project investigates DC power electronic traction transformers (PETT) to adapt the catenary voltage for the traction system of the trains.

Following the efforts in 2019 and 2020, the project team identified the modular multi-level topology as the preferred solution for AC/DC power converters of MVDC traction power substations. The assessment has been carried out with a comparison between the high-power converter topologies available in the literature and supported by a simulation model for the verification of the expected performance. The model has been extended to a meshed MVDC network comprising multiple traction substations and injection of power from photovoltaic panels. The analysis has shown that the designed MVDC substations meet the desired power quality level and is sufficiently robust to transfer the renewable power over medium distances without affecting train operations. Currently, a lab demonstrator of the AC/DC modular multi-level power converter is being built to verify experimentally some of the characteristics of the innovative traction power supply.

At the same time the simulation model of a DC-DC PECT of an electric locomotive was developed, including a traction inverter and motor. The results achieved so far have demonstrated that both dual active bridge and bidirectional phase-shift full-bridge converters are suitable for a multi-modular input-series output-parallel medium voltage PECT with satisfying results. The two topologies have been implemented and successfully tested in the laboratory and, currently, the experimental prototype of the whole setup (including a motor) is under development.

Rail System Architecture and Conceptual Data Model (CDM)

Through the year 2021 the LinX4Rails projects made real progress to achieve their goals: define an ontology dictionary, built a railway CDM and an associated architecture. To do so, workshops have been organised during 2021, including bi-monthly meeting on Architecture and CDM governance.

During 2021, the 1st release of the Functional System Architecture produced in Nov in 2020 was slightly updated. The 2nd release will come in early 2022. As an example, a view of the LinX4Rail railway system architecture with a 2 levels decomposition of operations is shown below:

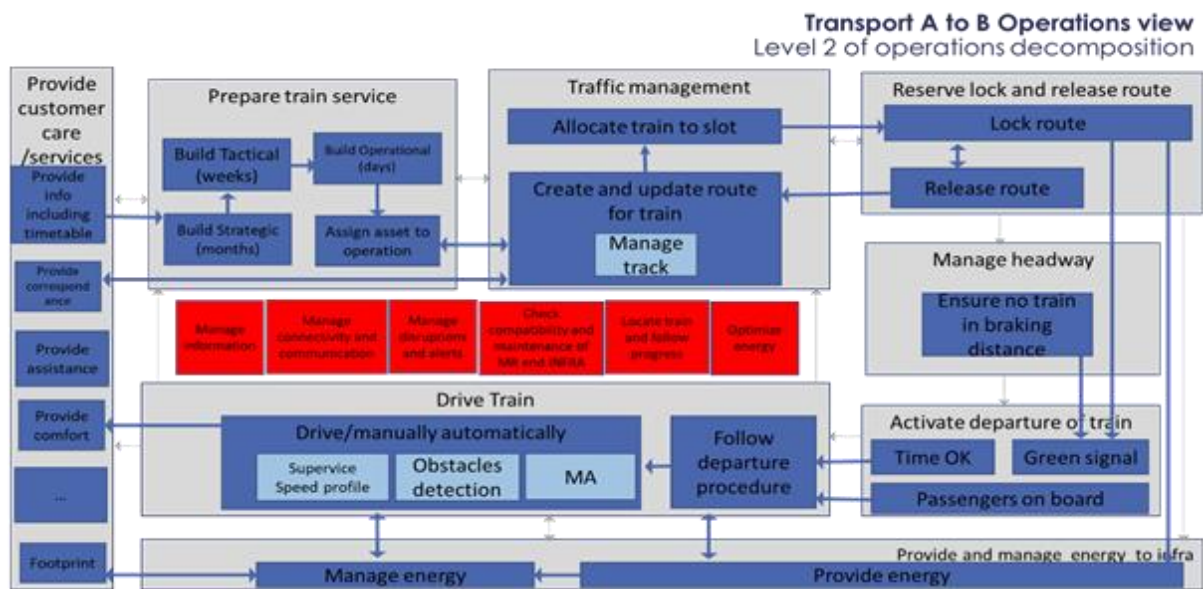

Late 2021, architecture workshops focused on identifying pain points in the current system (“As Is”) to be mitigated in the “To Be” system architecture for a better overall performance of the railway system which will be developed in the 2nd release of functional system architecture.

Progress has also been achieved regarding the development of the CDM based on ontologies by considering a federation of models (RSM, Eulynx, IFC Rail, X2Rail, ERA Vocabulary, Transmodel etc.).

At the moment, the integration of new models in the LinX4Rail dictionary is manual but ultimately its updates will be automated.

A major event was the ramping up of the System Pillar for which a collaboration with LinX4Rail was set up and is now running.

The LinX4Rail production in 2021 consisted in 5 technical deliverables describing the construction and the utilisation of the ontology dictionary, the CDM demonstration indicators and use cases description.

The dissemination of the LinX4Rail's outcomes was ensured by 2 webinars on architecture and CDM and papers foreseen for WCRR 2022 in Birmingham and possibly TRA 2022 in Lisbon (abstract to be validated by the congress committee).

1.5. Operational calls for tenders and prizes

With regard to the implementation of procurement activities, the JU has complied with the principles of the EU Financial Regulation and the guidance provided in the European Commission Procurement Vademecum. This resulted in the implementation of activities obtaining the best value for money.

The values established for the different procurement procedures, which are below any materiality level considering the total value of the R&I activities and the Programme, result from the collective knowledge of involved staff and their experience in previous private and public organizations.²⁴

In 2021, the JU awarded the following open tender procedures:

- Moulding tools for the S2R innovative doors and modular interiors technology demonstrators. A direct service contract with a total value of 209.836,00 EUR. In 2021, the contracts were signed with the contractor that will be providing the moulding tools as per the technical specifications provided (LOT 1 - Technology Demonstrator for the train car body shell: delivery of moulding tools for doors manufactured with composite materials using compression moulding process or equivalents; LOT 2 - Technology Demonstrator for the train modular interiors: delivery of moulding tools for modular interiors). The interim report describing the processes and all the detailed instructions that the contractor is undertaking were submitted and approved in the form of an interim report. The coordination of the activities is also ensured with the link to the CFM Project (PIVOT2) coordinator for these matters.
- Strategic support to the JU. Three framework contracts with a total value of EUR 3.300.000 and a 4-year duration:
 - LOT 1 - strategy advice: Covers the provision of strategy advice on the content and structure of the activities of the JU or/and the S2R Programme and the future JU remit. In 2021, three specific contracts were launched with the total budget of kEUR 1.122. The activities within the contracts support the development of the Europe's Rail Master Plan and its KPI definitions, the DAC Life Cycle Cost (LCC) analysis and DAC Investment Plan as well as the cost-benefit analysis including migration paths for the implementation of S2R innovations on the European network.
 - LOT 2 - support to Programme management: The objective of this lot is to support the JU with the implementation of the applicable Programme management processes and procedures, adapted to the specific JU Programme business needs and operations. In

²⁴ Also in answer to point 15 of Discharge 2016 of EP, reference P8_TA-PROV(2018)0173.

2021, two specific contracts were launched with a total budget of kEUR 250. The activities within the contracts support the delivery of Europe's Rail Master Plan and the preparatory activities to set up S2R's successor, as well as the delivery of EU-Rail Programme Members' In-kind contribution management and financial support.

- LOT 3 - legal assistance: The objective of this lot is to support the JU with the provision of services concerning legal support and assistance in different EU legal fields, such as public procurement, grant management, data protection, intellectual property rights (including copyright issues), pre-litigation and litigation support. In 2021, two specific contracts were launched with a total budget of kEUR 76. The activities within the contracts support the legal assistance to the preparatory activities to set up the S2R's successor, as well as the support to the continuation of the implementation of proper Data Protection rules for the JU.
- The inducement prize "S2R-Utrain-Prize-01-2020" launched in 2020 (with a total budget of EUR 500.000,00) was finally not awarded because the jury decided not to select any of the applications due to the insufficient quality of the proposed solutions and their demonstration. The Governing Board took note and acknowledged the non-award and decided the re-allocation of the budget initially committed²⁵.

In addition, in 2021 a procurement negotiated procedure under point 11.1(e) of Annex I to Financial Regulation (Reg. (EU, EURATOM) 2018/1046) was awarded to increase the amount of the framework contract "Support to ERTMS European Action Plan to pave the way for the deployment of the future S2R Innovative Solutions". The initial amount (EUR 8 million) was increased up to EUR 11 million.

In 2021, the implementation of the following framework contracts continued:

- **"Support to ERTMS European Action Plan to pave the way for the deployment of the future S2R Innovative Solutions"**. The objective of this tender is to ensure the establishment of the essential baseline for the deployment of the future S2R Innovative Solutions through the support to the coherent deployment of European Railway Traffic Management System, a horizontal priority aiming at ensuring in the interoperability of the EU railway system. The action is a part of a global project on deployment of ERTMS in the European Union, as defined in the TEN-T Guidelines and the MoU signed between the EC and the European Railway Associations in 2016. The estimated budget for the activities planned for 2021 amounts to EUR 2.6 million (specific contracts for 2021), including the work on the preparation of the CCS TSI 2022 as well as the activities aiming at preparing the launch of the EU-Rail System Pillar.
- **"Railway operators, staff and passengers' expertise" framework contract:**

LOT 1 - Expertise in European railway operations: in 2021, the following Specific Contract activities were launched:

- Coordination of European DAC (Digital Automatic Coupler) Delivery Programme WP1 Technology, Operations and Standardisation with a railway operators perspective and input, of a value of kEUR 168.
- Support for continuation with the work on System Architecture and development of CDM within LinX4Rail, with the following activities: Contribution to the Functional System Architecture, providing input to Linx4Rail, Contribution to Conceptual Data

²⁵ S2R JU GB Decision 09/2021 available at <https://shift2rail.org/about-shift2rail/structure-of-shift2rail-initiative/governing-board-2/>

Model (CDM) developments, Coordination of JU's input to ERA TWG ARCHI and Support to S2R Standardisation activities, with a value of kEUR 290.

- In addition, a specific contract of a value of kEUR 150 was also signed in order to cover the activities related to the ramp-up of the EU-Rail System Pillar and ensure the participation of Railway Operators in the process.

LOT 2 - Expertise in European railway human capital aspects: in 2021, the first Specific Contract was worth kEUR 45, with the objective to provide human capital expertise and input in the work performed in the L4R System Architecture activities that have identified human capital as a key asset.

LOT 3 - Expertise in European railway passenger aspects: in 2021, the second Specific Contract has been signed in order to receive expertise from the perspective of European railway passenger on some specific aspects relevant for the Joint Undertaking. Specifically, the following work areas were defined: support the development of the L4R rail Functional System Architecture, support the uptake of the S2R technologies defined in its programme and contribute to evolution of Rail Research & Innovation (Rail R&I) towards transforming Europe's rail system. The SC value is of kEUR 65.

- Call for Expressions of Interest for "Senior external experts to assist the S2R Joint Undertaking with high level support and advice in relation to the R&I activities".

As stated in point 3.3 of the Annex I of the Financial Regulation 2018/1046, the JU, as a contracting authority, shall publish a list of contracts on its website no later than 30 June of the following financial year for specific contracts under a framework contract. For the year 2020, the specific contracts implementing the FWC were published here: <https://shift2rail.org/participate/recipients-shift2rail-funds/>

1.6. Dissemination and information about projects results

The JU disseminates the project results at the heart of its R&I programme. Dissemination activities mainly target the European scientific and academic community working in the mobility field, and specifically rail, but not exclusively. Dissemination therefore plays an essential role within the S2R Programme, being a core ingredient of its success. Due to the Covid-19 pandemic, many communication and dissemination activities were concentrated online in 2021, however, the Connecting Europe Express, the flagship campaign of the European Year of Rail, and the S2R Innovation Days were an opportunity to bring S2R innovations to the railway industry, policy makers as well as the general public.

All JU dissemination activities are designed to consolidate the JU as the key European platform for R&I in the railway sector, where all interested parties, including manufacturers, infrastructure managers, rail operators and regulators can exchange in helping move European railway forward. The JU website hosts Call for Members Projects activities and links to Open Call Projects' websites and dissemination activities, as well as the Lighthouse Projects and other related projects (See also section 2.1).

Dissemination of project results was a prominent element of various S2R events during 2021, especially during the S2R Innovation Days (9-10 December) and the Connecting Europe Express (2 September – 7 October), which were the JU's two major communication events in 2021.

The S2R Innovation Days were conceived as a platform to promote JU results and to bring the sector together to discuss progress and future plans. The event was also considered a successful way of attracting a larger audience for the dissemination of the results of projects rather than the small-scale individual final events of projects which to date have gained little attention from participants outside of the organisations involved in the projects. During the S2R Innovation Days, the results of 26 projects were discussed in dedicated webinars, with an average view rate of 180 views per webinar (substantial increase from previous year, which saw 120 per views on average).

Furthermore, the dedicated 3D results area, which was developed in 2020, was further updated with new video content and allowed participants to navigate each of S2R's Innovation Programmes and explore the innovations being developed. The 3D area was embedded into the Innovation Days website, which allowed viewers to explore S2R innovations during the breaks in the conference programme. In the interest of further dissemination, the 3D results area was also updated on the corporate JU website and now includes all latest information on JU solutions.

Another major opportunity to further disseminate project results was during the Connecting Europe Express, flagship campaign of the European Year of Rail on 2 September – 7 October. The special train travelling across 26 European countries had a wagon dedicated to S2R innovations. The wagon included information about S2R Innovation Programmes with a dedicated iPad each to display latest videos on solutions coming from the projects. It was an excellent opportunity to showcase the work done by the projects to policy makers, railway community and the general public in Europe. More than 50 different videos coming from S2R projects were shown.

In addition to the physical exhibition, a virtual replica of the wagon was also available on the Connecting Europe Express website. This was an opportunity to disseminate project results to wider audiences, especially to those who were not able to visit the physical train. The virtual exhibition is available at the following link: <https://www.connectingeuropeexpress.eu/exhibition/>

Moreover, project results were also presented and discussed at a number of external events participated by JU staff, Members and project partners. More details on these events are available in Section 2.1.1.

2021 also saw an increased use of shared dissemination information among projects coordinated by the JU Communication Team. In January 2021 a new webpage on Project Results was launched in collaboration with the JU Programme Unit. Each month a number of selected results and deliverables coming from Shift2Rail projects are highlighted in this section of the website to ensure continuous communication about their achieved progress. The webpage includes a short description of each deliverable, giving a brief of account on how it brings us closer to achieving better rail for Europe. This approach has resulted in a multiplier effect as we have used this content for further promotion on our corporate social media channels and newsletter.

In 2021 we also created a new section in the JU newsletter specifically dedicated to project results. This section benefits from an increased click-through rate from our viewers. Additionally, in 2021, S2R has continued to promote projects final and mid-term conferences on social media channels, news section of the JU website and newsletter. The cross-projects collaboration of communication activities pushed by JU, has allowed for a more efficient promotion of this increased activity and a global overview of all project dissemination, ensuring we are able to promote results in a timely and effective manner. It also has enabled monitoring and the possibility to advise projects in the dissemination of their work in order to ensure they support the programme approach and contribute to the overarching JU communication strategy.

Project Final Conferences in 2021:

12 January – PLASA-2 Final Conference, Online
23 January – PINTA-2 Final Conference, Online
22 February – GATE4RAIL Final Conference, Online
23 February – SPRINT Final Conference, Online
30 June – Safe4Rail-2 Final Conference, Online
30 June – Connecta-2 Final Conference, Online
30 June – Flex-Rail Final Conference, Online
17 November – Fundres Final Event, Online
24 November – 4SECUrail Final Event, Online
7 December – Assets4Rail Final Conference, Online
9 December – X2RAIL-3 Final Conference (during S2R Innovation Days), Online
10 December – Translate4Rail Final Conference (during S2R Innovation Days), Online
10 December – FR8RAIL II Final Conference (during S2R Innovation Days), Online

1.7. Operational budget execution

In 2021, the final adopted JU Budget was comprised of kEUR 13.625 in commitment appropriations and kEUR 68.440 in payment appropriations.

At yearend 2021, the JU had implemented 100% of its commitment appropriations made available in its active budget (Titles 1 to 3). The payment appropriations were implemented up to 85% of the active funds. The implementation, when compared to the full JU budget (including Title 4), was 100% in commitment and 63% in payment appropriations.

By means of the GB Decision 08/2020 of 7 December 2020, the S2R Governing Board adopted the initial Annual Work Plan and Budget for 2021. There were two amendments adopted to this document in 2021. Both amendments aimed at maximizing the performance and impact of the JU.

Amendment number 1:

The Executive Director proposed to the Governing Board the following:

- To transfer the unused appropriations from the Union for the running costs of the JU in the amount of EUR 3,2 million to Title 3 for operational activities, plus an additional EUR 0,2 million coming from the operational unused appropriations. This transfer was in line with Article 16.2 of the Statutes of the S2R JU Regulation: *“If part of the contribution for administrative costs is not used, it may be made available to cover the operational costs of the S2R Joint Undertaking”*;
- To continue using the amount of the appropriations to be received from the Members other than the Union for the running costs of the JU in 2022 - 2024, as planned.

It was also proposed to make use of the aforementioned amount of EUR 3,4 million transferred to Title 3 to:

- Prepare and launch a topic under a call for proposals “innovation action” to support the European DAC Delivery Programme with activities between mid-2021 and 2022, to support the definition of the European solution. The expected activities will be defined taking account of the gaps identified within the DAC programme itself and considering the input of the JU Members;
- Prepare and launch, considering also the input received from ERRAC WG1 and its Scientific Committee’s Chair, an additional topic under the aforementioned call for proposals to identify

the overall benefits for the stakeholders, end users in primis, resulting from the R&I work of S2R and its successor;

- Prepare and launch a topic under a call for proposals “CSA”, if possible with a funding rate at 70%, to consolidate the progress of the Linx4Rail projects and, also, contributing indirectly to the preparation and launch of the activities of the future “System Pillar”; alternatively, realize the same activity making use of specific contract(s) within the ERTMS framework contract;
- Split the available budget appropriations equally between the two proposed topics.

The Governing Board approved the proposal of the Executive Director at its meeting of 23 March 2021; with particular regard to the concept of operations and functional system architecture (L4R projects’ consolidation here above), the use of the existing Framework Contract was agreed upon.

Amendment number 2:

In addition to the operational budget added in the Amendment no 1, it was proposed to the Governing Board to re-inscribe the unused appropriations from projects closed in 2020 and 2021 in the amount of EUR 2,9 million to Title 3 for operational activities. This has aimed at launching specific contracts within the existing framework contracts. Consequently, new specific contracts were added in the amended AWP 2021, and the relevant budget appropriations were adjusted. As a consequence, the new total for Title 3 amounted to EUR 9,6 million (see section below).

Finally, following the delay in the submission of some operational and other requests for payment, suspension of activities either due to the quality of technical reports received or in order to receive complementary elements confirming the achievement of the project results, the JU would not have been able to implement at least EUR 17,5 million of payment appropriations by the end of 2021. This amount was therefore transferred to the unused appropriations in order to be immediately re-inscribed into the payment appropriations of 2022 (with target implementation by Q1 2022).

In particular, kEUR 626 of unused administrative payment appropriations and kEUR 17.500 of unused operational payment appropriations, recorded under Title 4 in JU budget 2021, have immediately been re-allocated to the EU-Rail budget 2022 in accordance with the EU-Rail GB Decision 02/2021 of 21 December 2021 (Omnibus Decision), adopting the S2R Annual Work Plan and budget for 2022.

To support the planning of re-activating credits, the JU is making use of Title 4 in its budget. This Title is of technical nature and, in accordance with the EU-Rail Financial Rules, shows the appropriations available for applying n+3 rule on the following budgetary years. It is used to increase transparency and accuracy of the JU’s reporting. By allocating the appropriations in Title 4, they were identified as being used in the following years to meet the JU’s legal obligations on payments and the JU could re-activate them as part of the initial budget 2021. In accordance with the SBA, any S2R Programme unused appropriations that will be re-inscribed in revenue and expenditure from 2022 and onwards will be counted as being part of the EUR 600 million total Horizon Europe budget of EU-Rail Programme.

1.8. In-Kind Contributions

The in-kind contributions result from the activities carried out by the JU's members other than the Union, funded by the JU when in relation of awarded actions (IKOP) and/or not funded by the JU (usually Additional Activities and/or ICAA). They are not revenues in accordance with the budgetary accounting, hence they are not reported in the Budgetary tables and shall be excluded from any other purposes than the achievement of the SBA objectives.

Nevertheless, they constitute the essential component of the “partnership” nature of the Joint Undertaking.

1.8.1. Europes' Rail in-kind Contributions

As the EU-Rail started official on 30 November 2021, the operational activities performed in December 2021 in relation to EU-Rail are already summarized in Section 1.2. No contributions were received from the Union or its Private Members under the framework of the SBA.

1.8.2. S2R in-kind Contributions

The in-kind contributions received and reported in 2021 are solely related to the S2R Regulation.

As already indicated, in accordance with Article 174 of the SBA, EU-Rail is the legal and universal successor of the Shift2Rail JU (S2R JU). The rights and obligations in relation to the S2R Programme, hence, remain applicable under the current legal framework.

In this respect, in accordance with Article 4(3) of the S2R Regulation, *“the members of the S2R Joint Undertaking other than the Union shall report by 31 January each year to the Governing Board of the S2R JU on the value of the contributions referred to in paragraph 2 made in each of the previous financial years”*.

Article 4(2) of the S2R Regulation establishes that the total contribution to be provided by the S2R Other Members²⁶ and totalling EUR 470 million shall consist of:

IKOP²⁷ (in-kind operational): at least EUR 350 million, including at least EUR 200 million from the founding members other than the Union and their affiliated entities, and at least EUR 150 million from associated members and their affiliated entities. In accordance with Article 16(3)b of the S2R Statutes, IKOP consists *“of the costs incurred by them [the S2R Other Members] in implementing indirect actions less the contribution of the S2R JU and any other Union contribution to those costs”*.

ICAA (in-kind other activities): of at least EUR 120 million, of which at least EUR 70 million from the founding members other than the Union and their affiliated entities, and at least EUR 50 million from associated members and their affiliated entities. These contributions shall consist of the costs incurred by them in implementing additional activities outside the work plan of the S2R Joint Undertaking, which are complementary to this work plan and contribute to the objectives of the S2R Master Plan. Other Union funding programmes may support those costs in compliance with the applicable rules and procedures. In such cases, Union financing shall not substitute for the in-kind contributions from the Members other than the Union or their affiliated entities.

²⁶ The “S2R Other Members” consist of the Founding Members of the JU, with the exclusion of the Union, and the Associated Members.

²⁷ As laid down in Article 16(2) and Article 16(3)(b) of the S2R Statutes.

The aforementioned in-kind contributions, which consist of financial expenditure executed by the Members – salaries, assets, operations, etc. – to achieve the S2R Programme and its Projects, are in addition to the cash contribution of the S2R Other Members to the 50% of the running costs of the JU.

S2R Other Members' reporting for 2021

The S2R Other Member of S2R submitted their reporting on IKOP and IKAA to the JU by 31 January 2022.

The Lighthouse projects are excluded from this reporting as assimilated to open calls and within the administrative management of the European Commission.

This report covers IKOP related R&I activities as from Sept 2016 till Dec 2021; in terms of IKAA the activities are considered eligible as from the date of acceptance by the S2R Other Member of the S2R JU Statutes, by means of their respective letters of endorsement.

In accordance with Article 4(4) of the S2R Regulation, the S2R Other Member shall have the costs related to IKOP and IKAA certified by an independent external auditor appointed by the entity concerned.

IKOP and IKAA Certification

By 30 April 2021, the S2R Other Member have provided the JU with audit certificates on the IKOP and IKAA costs declared for the year 2020. After due examination of the relevant certification and, in particular, the audit standards applied to the issuance of the “audit certificates”, the acceptable corresponding IKOP contributions have been “validated” by the Executive Director and will therefore be accounted towards the obligation set in Article 4(2) of S2R Regulation to the S2R Other Member as well as recorder as Net Assets of the Joint Undertaking in the Annual Accounts 2020.

With regard to the Final Annual Accounts of S2R, all IKOP contribution reported but not validated in 2021 will be accounted for “to be validated” considering that:

- 85% of the IKOP reported “to be validated” is supported by the relevant certification; the rest is expected to be certified by year end;
- in accordance with the accounting principles, IKOP of year n-1 will be accounting for only in year n accounts, if and once validated in year n.

Additional information

IKOP

The progress and acceleration realized since the end of 2016 is confirmed and is well in line with the usual Programme Management S-Curve (with 64% of linear time consumed since September 2016 and with 78,5% of the IKOP objective reported).

As indicated under the definition of IKOP, these costs represent the difference between the Total Project Value and the EU-Rail co-funding (or estimated).

The 2021 IKOP is the cumulative result of the activities awarded by EU-Rail to the S2R Other Member:

	EUR million		R&I activities		%
	awarded and signed		realized		
	Sept 16 - Dec 21		2021	Sept 16 - Dec 21	
Total Value	622,9	113,1	469,5	75,4%	
S2R co-funding	272,0	52,6	194,0	71,3%	
IKOP	350,9	60,5	275,6	78,5%	

In order to allow EU-Rail to be in the position to sign the relevant grant agreements, the Union provided the necessary Commitment Appropriations to match the S2R Programme co-funding of EUR 272,0 million above (excluding OC), against the S2R Other Member' commitment of EUR 622,9 million. In terms of Union Payment Appropriations, they were used to provide the pre-financing up to 45% till 2019 and 55% for the call 2020 (to maintain cash flow in the current economic negative situation created by the C-19 pandemic) of the estimated funding in accordance with the relevant provisions of the grant agreements. In 2021, only two projects were signed following the call 2021 with limited contribution and impact from the S2R Other Member'.

It should be noted that the estimated requested co-funding included in the 2021 S2R Other Member' declarations is within the limits of the provision of the relevant Membership Agreements. In fact, Article 2.2 of each Other Member's Membership Agreement signed with EU-Rail establishes that "the Member agrees to limit its reimbursement request in indirect actions funded under Article 3(1)(a) of the S2R JU Regulation to an amount not exceeding 44,44% of the Member's total eligible costs in implementing indirect actions. In case of research and innovation activities delivering the expected results through a series of intertwined actions throughout successive S2R JU Annual Work Plans, and without prejudice to the provisions concerning co-funding rates established in the S2R JU Annual Work Plans, this 44,44% threshold shall be applied cumulatively taking into account the final amount of reimbursement requested at the end of the last action implementing the specific intertwined research and innovation activities".

The percentage resulting from the cumulative declarations in 2021 is 41,3%, within the maximum level of 44,44%.

However, it is to be noted that the intermediary reports of the following Members show the most important deviation with respect to an IKOP rate below 55,56%: Network Rail, Siemens, Amadeus, AZD Praha, CFW, Indra, Mermec, SmartRacon and Talgo.

This will be brought to the attention of the Governing Board for any remedial action to be taken and followed up by the EU-Rail in 2022 and in any case will result in a grant final payment which will correspond in a cumulative rate not exceeding²⁸ 44,44% rate.

IKAA

²⁸ In this respect, the Governing Board adopted Decision 16/2018 amending the S2R Other Members' model Membership Agreement.

In terms of IKAA, the total expected contribution by the end of the S2R Programme is now estimated, subject to certification, at EUR 208,8 million, **74% above** the regulatory obligation of minimum EUR 120 million. It is to be noted that EUR 176,3 million have been certified (47% above the regulatory obligation confirmed).

On 1 May 2022, based on the declarations and the Projects' cost statements, the situation of IKOP and IKAA was the following:

Other Members	TOTAL PROJECT COST				TPC/IKOP REPORTING						Validated as Net Assets	To be validated	Deviance as per MA Art 2(2)
	AAR 2016 - AAR 2020	AAR 2021	TOTAL	of which CERTIFIED	AAR 2016 - AAR 2020	AAR 2021	TOTAL	AAR 2016 - AAR 2020	AAR 2021	TOTAL			
Founding Members	209.809.770	59.222.504	269.032.273	240.922.656	88.091.755	25.659.745	113.751.500	121.718.015	33.562.759	155.280.773	105.387.365	49.893.408	
Alstom	37.396.570	7.562.743	44.959.313	44.959.313	14.311.551	5.460.962	19.772.513	23.085.019	2.101.781	25.186.800	21.202.697	3.984.103	43,98%
Hitachi - Ansaldo STS	27.513.243	8.937.826	36.451.069	36.451.069	12.150.272	3.649.110	15.799.382	15.362.971	5.288.716	20.651.687	15.284.499	5.367.188	43,34%
Bombardier Transportation	25.646.324	7.593.355	33.239.680	25.589.365	10.638.317	3.123.350	13.761.667	15.008.007	4.470.005	19.478.013	14.927.002	4.551.011	41,40%
CAF	26.968.250	6.691.745	33.659.995	33.270.242	11.159.112	2.253.417	13.412.529	15.809.138	4.438.328	20.247.466	16.292.542	3.954.923	39,85%
Network Rail	13.037.947	6.351.145	19.389.092	15.780.848	6.167.082	3.215.166	9.382.248	6.870.866	3.135.978	10.006.844	6.570.705	3.436.140	48,39%
Siemens	29.724.874	6.897.560	36.622.433	36.473.235	14.248.539	2.976.054	17.224.593	15.476.335	3.921.505	19.397.840	11.217.040	8.180.800	47,03%
Thales	21.865.109	9.132.082	30.997.190	22.823.707	9.604.498	3.826.822	13.431.320	12.260.610	5.305.260	17.565.870	4.479.149	13.086.721	43,33%
Trafikverket	27.657.453	6.056.050	33.713.502	25.574.879	9.812.384	1.154.864	10.967.248	17.845.068	4.901.186	22.746.254	15.413.733	7.332.521	32,53%
Associated Members	146.633.333	53.861.247	200.494.580	168.135.951	53.290.014	26.935.071	80.225.085	93.343.320	26.926.176	120.269.495	73.726.271	46.543.225	
Aerfitec	5.935.324	4.862.336	10.797.660	7.328.312	2.532.382	2.040.332	4.572.715	3.402.942	2.822.003	6.224.945	2.317.146	3.907.799	42,35%
Amadeus	2.117.623	2.397.260	4.514.883	4.508.487	543.731	1.838.417	2.382.149	1.573.891	558.843	2.132.734	1.068.476	1.064.258	52,76%
AZD Praha	4.253.437	1.707.927	5.961.364	5.961.364	2.119.876	1.073.091	3.192.967	2.133.561	634.836	2.768.397	2.133.561	634.836	53,59%
Competitive Freight Wagon	3.694.655	1.832.493	5.527.148	845.407	1.608.835	938.379	2.547.214	2.085.820	894.114	2.979.934	470.508	2.509.426	46,09%
Deutsche Bahn AG	37.260.983	4.414.459	41.675.442	41.393.105	8.132.038	4.842.711	12.974.749	29.128.946	428.252	28.700.693	24.701.871	3.998.823	31,13%
CS Group - Diginext	3.622.333	1.286.375	4.908.708	3.661.088	1.607.369	542.565	2.149.934	2.014.964	743.810	2.758.774	2.046.582	712.191	43,80%
EUROC	2.220.265	253.705	2.473.969	251.079	1.122.634	246.983	875.651	1.097.630	500.688	1.598.319	116.540	1.481.778	35,39%
Faiveley - Wabtec	11.769.016	3.552.004	15.321.021	14.466.401	4.440.763	1.238.491	5.679.254	7.328.254	2.313.513	9.641.766	6.810.932	2.830.834	37,07%
Hacon	9.538.398	3.944.208	13.482.606	13.481.309	4.142.279	1.633.684	5.775.963	5.396.118	2.310.525	7.706.643	5.300.215	2.406.428	42,84%
Indra	14.515.489	4.503.066	19.018.555	14.117.117	6.231.319	2.400.529	8.631.847	8.284.170	2.102.537	10.386.707	8.059.702	2.327.005	45,39%
Kontron - Kapsch	6.615.069	731.198	7.346.267	6.926.379	2.807.568	280.293	3.087.861	3.807.501	450.905	4.258.406	3.430.024	828.382	42,03%
KnorrBremse	7.993.296	3.090.669	11.083.965	11.083.965	3.023.802	478.674	3.502.476	4.969.494	2.611.995	7.581.489	4.778.653	2.802.837	31,60%
MerMec	5.349.797	1.561.157	6.910.954	6.910.954	2.312.099	854.150	3.166.249	3.037.698	707.007	3.744.705	3.034.210	710.495	45,81%
SmartDeMain	6.544.738	778.198	7.322.936	5.772.622	2.753.047	240.065	2.993.112	3.791.691	538.133	4.329.824	567.870	3.761.954	40,87%
SmartRaCon	4.477.000	4.402.331	8.879.331	1.419.483	1.831.716	3.449.294	5.281.010	2.645.284	953.036	3.598.321	-	3.598.321	59,48%
SNCF	3.718.142	5.066.320	8.784.462	8.565.307	1.615.640	1.509.546	3.125.187	2.102.501	3.556.774	5.659.276	-	5.659.276	35,58%
SWITRACKEN	1.867.712	3.042.144	4.909.856	130.028	800.344	1.112.335	1.912.679	1.067.368	1.929.809	2.997.177	38.537	2.958.640	38,96%
Talgo	4.243.553	2.988.042	7.231.594	7.231.594	1.403.854	2.175.898	3.579.752	2.839.699	812.144	3.651.843	2.310.726	1.341.117	49,50%
Virtual Vehicle Austria Consortium VVAC+	10.896.505	3.447.355	14.343.860	14.081.950	4.260.718	533.600	4.794.318	6.635.786	2.913.756	9.549.542	6.540.717	3.008.825	33,42%
Total	356.443.103	113.083.751	469.526.853	409.058.608	141.381.769	52.594.816	193.976.585	215.061.334	60.488.935	275.550.269	179.113.636	96.436.633	41,31%

IKAA REPORTING				
Other Members	In-Kind Additional Activities as at 1 June 2021	In-Kind Additional Activities as at 30 April 2022	TOTAL	<i>of which Certified as at 30 April 2022</i>
Alstom	11.912.418	-	11.912.418	11.912.418
Hitachi - Ansaldo STS	7.145.861	2.367.833	9.513.694	5.794.531
Bombardier Transportation	15.688.168	-	15.688.168	15.688.168
CAF	8.946.296	-	8.946.296	8.946.296
Network Rail	2.220.203	-	2.220.203	-
Siemens	10.950.000	-	10.950.000	10.950.000
Thales	7.865.105	-	7.865.105	16.267.311
Trafikverket	25.159.312	-	25.159.312	-
Founding Members	89.887.363	2.367.833	92.255.196	69.558.724
Aerfitec	2.568.448	-	2.568.448	1.848.984
Amadeus	17.496.678	-	17.496.678	17.496.678
AZD Praha	2.852.200	313.880	3.166.080	2.852.200
Competitive Freight Wagon	631.132	-	631.132	141.239
Deutsche Bahn AG	29.084.129	-	29.084.129	29.084.129
CS Group - Diginext	1.196.244	-	1.196.244	530.000
EUROC	3.880.016	-	3.880.016	-
Faiveley - Wabtec	4.719.214	9.527	4.728.740	4.562.939
Hacon	17.610.377	434.968	18.045.346	17.610.377
Indra	4.724.412	600.000	5.324.412	4.630.412
Kontron - Kapsch	3.980.835	-	3.980.835	3.980.835
KnorrBremse	9.346.664	25.708	9.372.372	9.346.665
MerMec	2.566.245	54.000	2.620.245	2.566.245
SmartDeMain	3.493.721	-	3.493.721	2.782.822
SmartRaCon	992.453	-	992.453	553.618
SNCF	934.632	-	934.632	404.414
SWITRACKEN	211.892	-	211.892	2.461
Talgo	2.906.321	-	2.906.321	2.906.321
Virtual Vehicle Austria Consortium VVAC+	5.886.907	-	5.886.907	5.403.795
Associated Members	115.082.522	1.438.083	116.520.605	106.704.136
Total	204.969.885	3.805.916	208.775.801	176.262.859

Programme as at Dec 2021 - TPC Million EUR

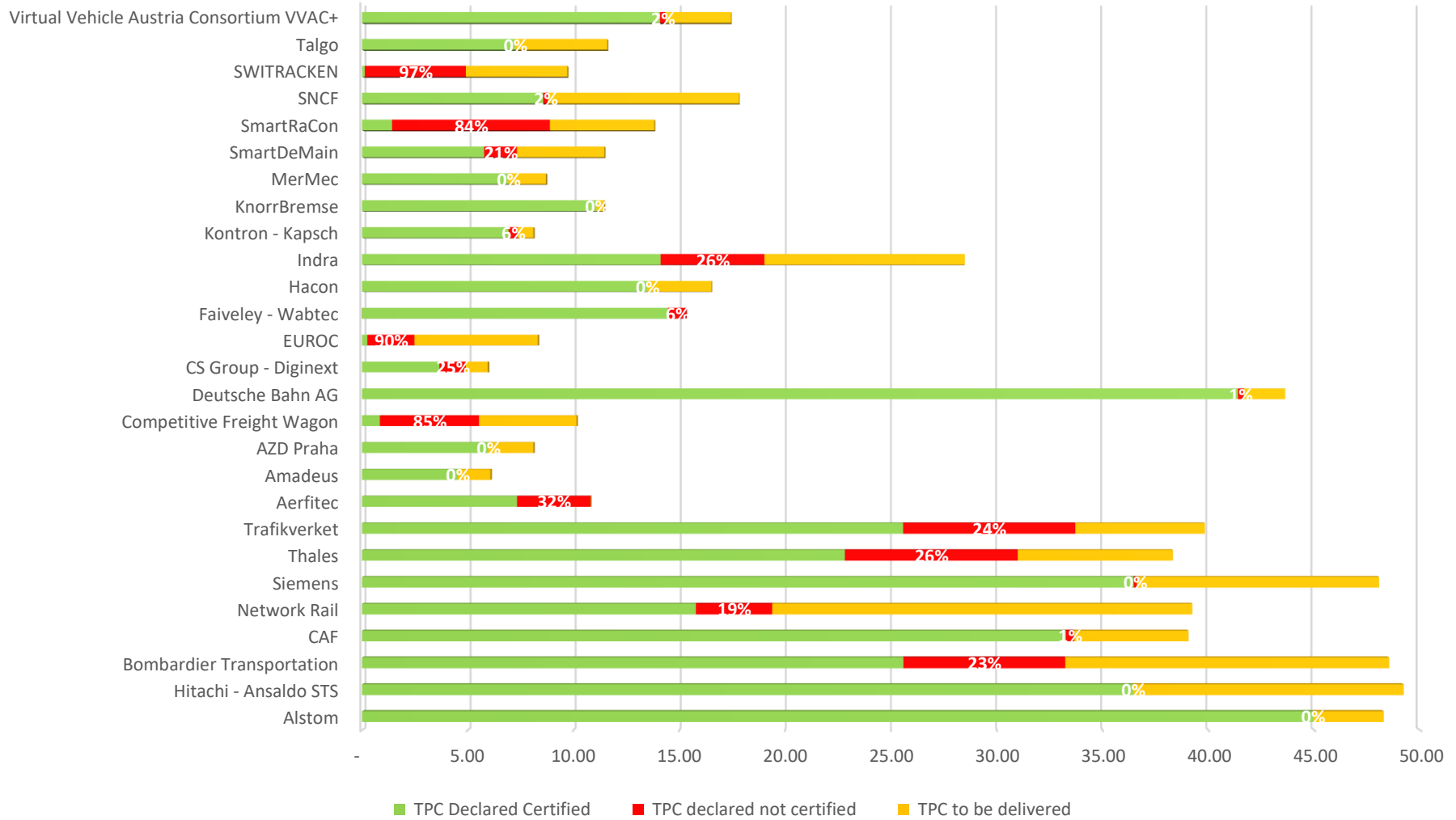

1.9. Synergies with the Union Programmes, Funds and national funded R&I

In terms of national funded R&I activities in the Railway sector, the JU invites the relevant Member States to present their programmes and projects in the context of the meetings of the SRG. This allows discussion on ways to interconnect the different activities and ensure that resources are leveraged to achieve the best results. This is an ongoing process, which becomes increasingly relevant in view of standardisation processes and market uptake.

During 2021, the ongoing work on collaboration agreements, in the form of a Memorandum of Understanding (MoU) or cooperation agreement, which the JU may sign with various European regions and Member States, European and international organizations and bodies was pursued as indicated in the previous sections.

In addition, the JU also further explored synergies with other JUs. The collaboration with the Fuel Cell and Hydrogen (FCH) Joint Undertaking started in 2018, with the co-tendering of a Study on the use of Fuel Cells and Hydrogen in the Railway Environment. This resulted in three reports being jointly presented and published on the respective websites²⁹. The cooperation FCH JU / S2R JU came to the attention of the European Parliament and led to a joint presentation, notably with a workshop on “The use of hydrogen fuel in transport” in the European Parliament on March 16, 2021.

This collaboration sets the basis for the future alignment of the respective programmes in view of the hybridization of rail systems making use of the FCH technologies.

Furthermore, because of this identified synergy and following the study recommendations for R&I, FCH JU inserted in their 2020 AWP a R&I call on Extending the use cases for FC trains through innovative designs and streamlined administrative framework, as Innovation Action with a funding of maximum 10 million euros. A project with the participation of some S2R Other Member has been selected for funding and it is currently running, FCH2Rail, with train demonstrator tests to be carried out cross-border in Portugal and Spain and authorisation will be sought for three EU countries.

Active exchanges for future programmes design and synergies, respectively for Europe’s Rail and Clean Hydrogen, happened all along 2021.

The JU enhanced its collaboration with the SESAR JU on the matters related to traffic management and functional system architecture, inviting the experts to present their approaches in the S2R project Linx4Rail which aims to create an innovative rail functional system architecture.

Additionally, the JU conducted several exchanges with the new PPP on batteries Batt4EU, looking for priorities alignments and synergies across programme, in particular with Europe’s Rail.

Similarly, initial talks were initiated in 2021 with EuroHPC JU in order to look for possible services offered when in the course of the new programme significant computing capabilities would be needed (e.g. for traffic management prediction at European scale).

The JU also became an official member to the Digital PRIME working group, promoted by the European Commission together with rail infrastructure managers around traffic management improvements mainly.

²⁹ <https://shift2rail.org/publications/study-on-the-use-of-fuel-cells-and-hydrogen-in-the-railway-environment/>

The Programme Office and Executive Director also regularly exchanged best practices and ideas for future synergies mainly with Clean Hydrogen JU, SESAR JU and Clean Aviation JU at programme level and with all other JUs at administrative level.

In terms of synergies with other Union Programmes, the JU works closely with the other Joint Undertakings sharing the same building, infrastructure, etc. maximising the opportunity for collaboration in terms of administrative and operational activities.

In addition, following the entering into force of the SBA further synergies are expected to be implemented in the areas identified in Article 13 SBA. This will be a major endeavour during the year 2022, in collaboration with the other involved Joint Undertakings.

1.10. Launch of Calls for Proposals and Tenders during 2021

On 19 November 2020, the JU GB adopted the AWP 2021 and budget³⁰ that resulted from the work performed by the JU with its Members, partners and Bodies during large part of 2020. The focus of the work in 2021 was on delivering the programme activities.

Based on a proposal of the Executive Director at its meeting in March 2021, the Governing Board agreed to launch a final call in 2021.

With the Call 2021 activities up and running, the overall R&I activities performed in the Programme will reach EUR 805,1 million (including Lighthouse Projects as part of the S2R initiative), of which EUR 654,3 million performed by the S2R Other Members with a funding made available by the JU up to a maximum of EUR 303,4 million.

While in accordance with the respective Membership Agreements the S2R Other Members agreed to limit their request for funding to 44,44% of the Total Project Costs, the OC topics are co-funded at the rates established in the H2020 Rules of participation.

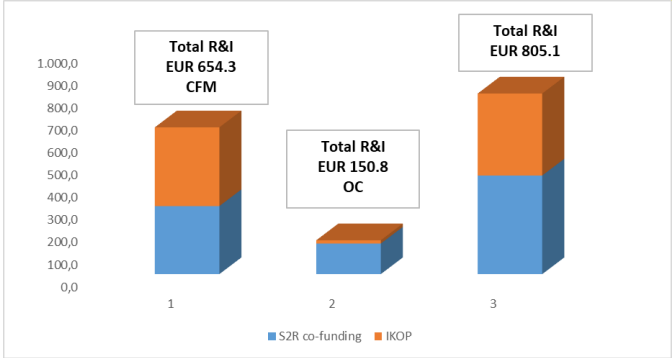

S2R JU R&I running activities with the Call 2021 included

³⁰ The AWP 2021 was amended in 2021 by the GB. Revised version is available at: <https://shift2rail.org/about-shift2rail/reference-documents/annual-work-plan-and-budget/>

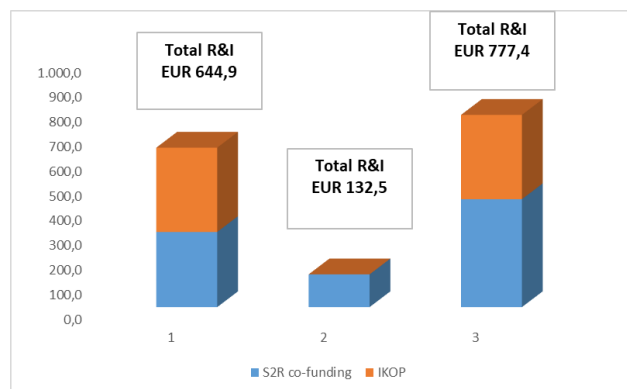

S2R JU R&I activities Programme expected objectives

It is therefore important to mention that the S2R R&I activities are expected to exceed the objectives as described in the JU Council Regulations. This will be further confirmed during in 2022 and beyond.

2. SUPPORT TO OPERATIONS

2.1. Communication activities

The JU continued to promote the activities of the programme during 2021, while continuing to adjust to the challenges and restrictions imposed by the Covid-19 pandemic. The JU communication activities in 2021 were focused on the continued promotion of the S2R Programme, and bringing as much visibility as possible to the results of its R&I activities, especially due to the strong interest in rail as a consequence of 2021 being declared the European Year of Rail.

Most communication activities in 2021 revolved around organisation and participation to events in the frame of the European Year of Rail, as well as communicating about the progress related to the new EU-Rail programme. At the end of the year, once the Regulation establishing the new joint undertaking came into force, the JU communications placed a great emphasis on disseminating key information about the Programme. In this context, a transition logo was developed to bring attention to the transition between the two programmes. As of December 2021, the new logo was used on social media accounts, website and newsletter, as well as all visual communication material published on these channels.

Promotion of the 2021 Call for Proposals was as usually a focus of the yearly communication activities. The 2021 Call for Proposals was widely promoted through website, newsletter and social media channels, and this promotional content was successfully re-shared by S2R Members and partners as well as reported on in the press (see Annex E).

In 2021, the JU Communications successfully organised two meetings with the communication officers of Members' companies to align on the messaging to be used during the European Year of Rail. Furthermore, the meetings were used as an opportunity to involve Members in events organised by the JU.

In parallel to the key events organised and participated in by the JU during 2021, the JU continued to build its audience and revamped its stakeholder mailing list in order to ensure that news are reaching the correct audiences. For instance, the press mailing list was fully reviewed and updated. This, in turn, resulted in strengthened press relations in 2021, increasing media presence not just in specialised rail

press (particularly in the Railway Gazette, International Railway Journal, Global Railway Review, and Railway Pro – all press articles are listed in Annex E), but also in more mainstream press outlets, such as Euro News. In 2021, the JU signed media partnerships with Railway Gazette, BtoB Magazine and the European Files. The JU also had a collaboration agreement with Rail Live organisers.

Moreover, in 2021 the JU was also reaching out to new audiences. For instance, one example was the organisation of Hack2Rail, an online hackathon launched in collaboration with the JU Member Siemens Mobility. It was an opportunity to build contacts with students, start-ups, designers and entrepreneurs and explore possible collaboration opportunities with these groups. As a result of the hackathon, JU channels gained following of new audiences, with a strong emphasis on younger people.

The JU continued revamping its website by introducing new features and improving user friendliness, as well as increasing its presence on social media, largely thanks to the European Year of Rail campaign, in which the JU was a major player.

During 2021, the JU published: The Annual Activity Report 2020, and the updated S2R Factsheet. Both publications were promoted during various events in presence, most prominently, the Connecting Europe Express.

As a key actor of the European Year of Rail taskforce, under the European Commission's DG MOVE, work on implementing the European Year of Rail communication strategy created in 2020 was performed and delivered. In February 2021, the JU created and published on its YouTube channel the first video dedicated to the European Year of Rail. This video was created in collaboration with the taskforce and was later included on the European Year of Rail website, attracting nearly 40k views. Furthermore, the JU was also part of the Connecting Europe Express planning taskforce, directly contributing to the development of the initiative. The JU funded a dedicated CEE exhibition wagon, together with CINEA, showcasing some of S2R Programme most recent innovative solutions. The JU branding was further included in the design of the train, clearly indicating its involvement in the project.

It is also worth mentioning that, in collaboration with the ICT officer, a project was launched to improve internal communication in the JU. An intranet page was set-up to better inform colleagues about the JU news, as well as reduce email communication.

In 2021 the JU made additional efforts to ensure that relevant stakeholders are aware of its mission, activities and achievements, by taking the following measures:

- 1. Promotion of 2021 Call for Proposals:** the JU ensured the launch of the Call was effectively communicated to all relevant stakeholders, including stakeholders across the entire railway value chain, with a particular attention to SMEs, research and technology centres and universities. Subsequently, the Call's participation and final results were also widely promoted through all corporate channels and picked up by different press outlets.
- 2. The second edition of the S2R Innovation Days** ensured that the progress of the programme was shared with a wide range of stakeholders on 9-10 December 2021. More than 1000 registered participants had the opportunity to take stock of the European Year of Rail, see how far our innovations have come, and what to expect at InnoTrans 2022, providing an additional base for the Europe's Rail Joint Undertaking. The Innovation Days were an opportunity to hear from high-level representatives from the European Commission, including the European Commissioner for Transport, Adina Vălean, the Belgian Government, including the Deputy Prime Minister of Belgium, Mr. Georges Gilkinet and from S2R Members and partners about

the European rail transformation, space for innovation in rail, collaboration with international entities, disruptive technologies like hyperloop, among other topics. A hybrid format was chosen, comprising live studio sessions and Zoom webinars. Several sessions about S2R's Innovation Programmes dedicated to running projects were held. Furthermore, a virtual exhibition area was on display throughout the event allowing visitors to see the latest developments of the technological demonstrators.

- 3. The organisation and participation in specific activities, workshops and events** (mainly through virtual means) in order to promote the S2R Programme and inform about the achievements of the JU worldwide. The JU participated to nearly 60 different events across Europe and beyond, strongly showcasing the partnership's importance within the rail and transport communities globally. The S2R Programme and its results were showcased ensuring a strong dissemination of the programme's activities. One example is an event organised in collaboration with European Commission's Directorate-General for Research and Innovation. the JU organised a workshop on 24 June during the European Research and Innovation Days - the European Commission's flagship event shaping the future of R&I in Europe. The workshop featured an all-female panel from our Member companies Hitachi Rail, Indra Sistemas and ÖBB Austrian Railways. The speakers presented a selection of S2R Programme's key innovations that will have a significant impact on the future of rail, including ATO, DAC and the Travel Companion. A full list of events organised and participated in by the JU to ensure stakeholder engagement is available in section 2.1.1. and Annex E of the Annual Activity Report 2021.
- 4. The European DAC Delivery Programme**, launched at the end of 2020 and enabled by the JU, offers a unique European platform for cooperation and collaboration between railway undertakings, infrastructure managers and wagon keepers, as well as the rail supply industry, entities in charge of maintenance, concerned sector organisations, rail research centres and national and European political institutions. The programme is aimed at building upon R&I results and pilots to ensure the necessary actions for a fast, technically and economically feasible European-wide roll-out. A dedicated area of the website was created for the newly established [European DAC Delivery Programme](#), and the JU is working closely with the dedicated dissemination group to ensure effective communication of this initiative, open to all interested stakeholders, that has already received significant media attention. The JU Communications continued enhancing communication around the programme, by regularly publishing news items and press releases about the topic, in close collaboration with Work Package 6 of the programme. Communications also organised sessions around the topic, specifically during the Rail Broadcast Week, the European Research and Innovation Days and the S2R Innovation Days.
- 5. The [Decision to designate 2021 as the European Year of Rail](#)** was adopted on 23 December 2020 by the European Parliament and the Council of the European Union. The JU was a member of the European Year of Rail taskforce, under the European Commission's DG MOVE leadership, and has been working on implementing the European Year of Rail communication strategy created in 2020. For instance, in February 2021, the JU published on its YouTube channel a video dedicated to the European Year of Rail. The video was created in collaboration with the taskforce and was later included in the European Year of Rail website, attracting nearly 40k views. Furthermore, the JU was also a key part of the Connecting Europe Express planning taskforce, directly contributing to the development of the initiative. A dedicated exhibition R&I wagon, shared with CINEA, was part of the CEE, showcasing some of S2R most recent innovative solutions and the deployment projects funded by CINEA. The JU branding was further included in the design of the train, clearly indicating its involvement in the project.

- 6. Targeted communication through JU corporate channels** has allowed the JU to continue to build its audience and stakeholder mailing list. This included revamping the website, improved pages on events and increased user-friendliness of the website. Additionally, the JU strengthened its presence on social media significantly by providing news to the already converted but also reaching out to new audiences. The JU increased its online presence significantly and dedicated time and resources to improve the content and frequency of its posts across its social media accounts – Twitter, LinkedIn, Facebook, YouTube – to engage with the rail community, aiming to constantly inform all stakeholders. The average number of tweets per month was 44, while in 2020 the average number was 35, showing a significant increase in social media activity. Moreover, the JU has also increased its presence on its YouTube channel. Efforts have been made to publish videos showing our innovations as well as recordings of our online events to ensure that even those who were unable to join can access the content.

The JU continued to build its audience and revamped its stakeholder mailing list in order to ensure that news is reaching the correct audiences. For instance, the press mailing list was fully reviewed and updated. This in turn resulted in strengthened press relations in 2021, increasing media presence not just in specialised rail press (particularly in the Railway Gazette, International Railway Journal, Global Railway Review, and Railway Pro – all press articles are listed in Annex E), but also more mainstream press outlets, such as Euro News. The JU signed media partnerships with Railway Gazette, BtoB Magazine and the European Files and had a collaboration agreement with Rail Live organisers.

- 7. Increased communication partnerships with DG MOVE, DG RTD, ERA, CINEA and other EU-institutions** was further consolidated in 2021 under the European Year of Rail. This has included the sharing of editorial plans and outputs for mutual dissemination through corporate channels, helping to spread and reinforce the Union’s policy objectives in the mobility and transport area. Additionally, as already indicated, the JU and CINEA set-up a joint exhibition on the Connecting Europe Express train, showing a clear link between research and innovation activities done within the S2R Programme and the deployment activities carried out by CINEA. Furthermore, ERA’s logo was included in the exhibition to further strengthen the link between rail institutions in Europe.
- 8. An initial re-design of the webpages** was required to introduce and explain Europe’s Rail, compiling all relevant information and documentation about the new programme, its members and partners, as well as key publications, such as draft Master Plan and draft Multi-Annual Work Programme.
- 9. Stakeholder management and external relations** have been maintained through a close collaboration with the European Union Agency for Railways (ERA) in different areas, with the European Railway Research Advisory Council (ERRAC), as well as with the different International and European organizations and associations. A continuous and constructive exchange took place with other Union bodies and agencies, such as GSA, FCH JU, SESAR JU, CleanSky JU, EASA and others.
- 10. Cooperation in Member States as well as with international parties** was also increased in 2021:
- a. On 10 June 2021, the S2R JU signed a Memorandum of Understanding (MoU) with the European Committee for Standardization (CEN) and the European Committee for Electrotechnical Standardization (CENELEC). It aims at formalising the already existing close collaboration between CEN and CENELEC, two of the officially recognised European Standardization Organizations, and the Joint Undertaking. Through this

agreement, the participating organizations are committed to foster the uptake of innovation in the railway sector and contribute to maintaining the EU as a world leader.

- b. The signature of the Memorandum of Understanding between the Joint Undertaking and the International Union of Railways (UIC) took place at the UIC General Assembly, on Thursday 8 July at UIC's premises in Paris. The objective of this Memorandum of Understanding is to promote cooperation between UIC and the JU to support the structured implementation of innovative solutions, and to deliver a functional system approach that is suited to the operational needs of the sector and, in particular, the final users.

2.1.1. Events

The JU participated in a number of institutional events (i.e. led by the European institutions), external and internal meetings and conferences, as well as webinars. Due to the COVID-19 pandemic, major events have been postponed to 2022 or cancelled, including Innotrans and TRA.

Institutional events

Connecting Europe Express – 2 September – 7 October 2021, Europe

Under the backdrop of the European Year of Rail, the European Commission together with industry partners organised the Connecting Europe Express, a train connecting the three Presidencies of the Council of the European Union, Portuguese, Slovenian and French. The Connecting Europe Express criss-crossed 26 countries and traced many of the routes that bind us together, connecting countries, businesses and people. The initiative showcased the unifying force of rail. Its role was to make us better understand the challenges that European rail has to overcome in order to become the mode of choice for passengers and businesses alike.

As key part of the Connecting Europe Express train, a wagon was dedicated to the JU innovations shared with CINEA. The JU hosted various representatives from the transport sector in the exhibition coach showcasing some of our key solutions throughout the journey. Visitors included the European Commissioner for Transport Adina Vălean, Director-General Henrik Hololei, various MEPs as well as Prime Ministers and Minister of the different visited countries. On selected stops, the public was also able to enter the train and experience first-hand how our work is contributing to advanced mobility in the region.

Additionally, the JU presented its work in the field of rail freight during the Connecting Europe Express flagship conference in Luxembourg. The event took place on 5 October in Bettembourg and focused on multimodal transport and rail freight.

European Year of Rail launch event – 29 March 2021, Online

The official launch of the European Year of Rail, organised by the European Commission, took place online on 29 March under the Portuguese Presidency of the Council of the European Union.

The JU participated to the ceremony in a panel discussion dedicated to 'Rail Infrastructure, Connectivity and Territorial Cohesion'.

European Parliament's Committee on Transport and Tourism Workshop on Hydrogen – 16 March 2021, online

The JU was invited to participate to European Parliament's Committee on Transport and Tourism webinar covering topics related to hydrogen solutions in Europe. A keynote speech was delivered and focused on collaborative approach to automatic train operation development and presented results from two trials.

European Research and Innovation Days – 24 June 2021, online

Together with Directorate-General for Research and Innovation, the JU organised a workshop on 24 June during the European Research and Innovation Days - the European Commission's flagship event shaping the future of R&I in Europe.

The workshop featured an all-female panel from our Member companies Hitachi Rail, Indra Sistemas and ÖBB Austrian Railways.

The speakers presented a selection of the JU key innovations that will have a significant impact on the future of rail, including ATO, DAC and the Travel Companion.

JU events

S2R Innovation Days – 9-10 December, 2021, Brussels, Belgium and online

The second edition of the S2R Innovation Days took place on 9-10 December in a hybrid format and brought together over a thousand registered participants from across Europe and beyond, as well as more than 40 plenary and 100 webinar session speakers.

During the Opening Session, participants had the opportunity to witness the successful driverless train demonstration from the Czech Republic carried out by our Members AŽD, Thales and Kontron. The demo is a perfect example of the progress achieved in our R&I programme.

We were honoured to be joined by the Deputy Prime Minister of Belgium and Minister of Transport, Georges Gilkinet, who stated: "Without access to transport, one cannot gain access to employment, education, social activities, and much more. Rail transport has a key role to play in achieving these goals, in taking its place as the backbone of sustainable travel, in a multimodal mobility ecosystem."

Director-General for Mobility and Transport, Henrik Hololei, in his opening remarks, highlighted the expectations he has for the new Europe's Rail Joint Undertaking. He added that: "The Innovation Days provide the ideal platform to take stock of the European Year of Rail, share the memories from events, conferences and of course from the unforgettable Connecting Europe Express".

The closing and Awards ceremony in the presence of Walter Goetz, Head of Cabinet of the Commissioner for Transport Adina Valean provided a strong message on the expectations for the Europe's Rail Joint Undertaking partnership, especially in the context of the Sustainable and Smart Mobility Strategy. Mr Goetz said: "Europe's Rail partnership is essential to ensure we have an innovative and fully functioning rail in Europe".

Almost 800 participants got first-hand access to the latest results coming from across the S2R Innovation Programmes in sessions dedicated to our running projects.

A virtual exhibition area was further updated with new content allowing participants to see the JU latest technological demonstrators and the progress we are making in bringing innovative solutions to the market.

Hack2Rail – 29 October 2021, online

The JU together with Siemens Mobility organised an online hackathon “Hack2Rail” with the aim to develop innovative solutions for two important challenges: Passenger Rail and Rail Freight.

We invited interested participants and start-ups to create Europe’s future rail solutions who had a unique opportunity to collaborate and exchange with mentors from key European rail organisations, get access to exclusive webinars and participate to matchmaking sessions.

Finalists of the joint hackathon pitched their innovative ideas to a high-level jury, under the patronage of Ms Adina Vălean, European Commissioner for Transport, and co-chaired by Mr Kristian Schmidt, Director of Land Transport, DG MOVE, European Commission and Ms Rosalinde van der Vlies, Director of Clean Planet, DG RTD, European Commission for a chance to receive a cash prize of 10,000 EUR, be invited to high-level European Year of Rail events and, potentially, have the opportunity to work with Siemens Mobility or any other JU Member.

The first place was awarded to AI Powered Predictive Scheduling, the second place to Zero Carbon, and third place to EnterTrainMe.

In total over 200 participants from over 30 countries and 100 organisations submitted projects under two main topics – passenger rail and rail freight – with two challenges each. Participants could choose to work on one of the four challenges, namely seamless travel, and better stations for passengers, as well as sustainable options and efficient planners for freight. The ideas were evaluated by 14 mentors - rail experts from JU’s Member and stakeholder representatives. In total 20 projects were selected for the hackathon which took place on 23-24 October, while ten ideas were selected for the Final Demo Day on 29 October.

External events

In 2021, the JU participated to major rail, transport and research events, presenting concrete results achieved by JU Members together with other key stakeholders. A selection of the most high-profile and relevant events are listed below, while a full list of external events can be found in Annex E.

European Start Up Prize for Mobility Grand Ceremony - 13 January 2021, online

Executive Director was part of the jury for the European Startup Prize for Mobility 3rd Edition Final Ceremony. Along with special guests Maroš Šefčovič (European Commission Vice-President), Lilyana Pavlova (Vice-President of the European Investment Bank) and Karima Delli (Chair of the European Parliament’s Committee on Transport and Tourism).

The JU helped to select the most innovative start-ups working on the mobility solutions of tomorrow and encouraged more start-ups to start working on rail-related solutions.

Portugal Railway Summit – 2-3 February 2021, online

Executive Director spoke about the advantages of participating to JU and the future of rail in Europe.

UIC Railway Noise Days – 23-24 February 2021, online

JU Programme Manager covering Cross-Cutting Activities across our R&I programme, participated to the UIC Railway Noise Days on 24 February. She talked about S2R Programme solutions contributing to noise and vibration mitigation.

The workshop was an opportunity to provide an update on the most important issues and developments in the field of railway noise as well as discuss next steps with relevant stakeholders.

10th International Railway Summit – 23-26 February, online

The JU played an active role at the 10th International Railway Summit, moderating three interesting sessions.

The JU moderated two sessions devoted to the passenger experience. The first on “Designing a smoother and quieter passenger experience”, took place on 23 February and the second panel discussing “Passenger-friendly multimodal ticketing” took place on 25 February.

The Head of Research and Innovation moderated a third panel titled “The power of sustainability: attracting freight customers to rail” on 25 February.

The Executive Director spoke about our work in the field of ATO, with a particular focus on IP2.

EuroRail Hub – 25 March 2021, online

The Executive Director gave a keynote speech on ‘Shift2Rail's role in the European railway of tomorrow’ during the EuroRail Hub event.

For the first time, Railtex, Infrarail, SIFER and EXPO Ferroviaria launched a united digital event with the aim to support the recovery of the European rail market through interactive digital networking opportunities.

JU at UNECE workshop – 26 March 2021, online

On 26 March, our Executive Director, Mr Borghini, participated to a UNECE workshop on physical climate change risks in transport.

During the workshop experts on climate change and inland transport helped develop guidance aimed at the needs of transport professionals.

S2T ATO over ETCS webinar – 30 March, online

The webinar organised by our Innovation Programme 2 and Innovation Programme 5 projects X2RAIL1, X2RAIL3 & ARCC explored the collaborative approach to Automatic Train Operation (ATO) development and presented results from two trials undertaken on an operational railway in the UK and Switzerland in 2020.

The Executive Director participated in the event along with other ATO experts, including suppliers, infrastructure managers and operators on 30 March.

ERCI Webinar on ERRAC SRIA and future perspectives of rail research (part of the European Rail Systems Technology Week (#ERSTW) – 14 April 2021, online

The Executive Director participated in a workshop organised by the European Railway Clusters Initiative (ERCI). The workshop explored future research perspectives in the rail sector under the European Union’s research and innovation framework programme, Horizon Europe.

P&T Innovation Week – 27-30 April 2021, online

The JU participated in the Innovation Week organised by our Associated Member Plasser & Theurer. The conference featured a digital showroom and focused on a range of services offered for Machine Fleet Infrastructure.

The Executive Director, Head of Research & Innovation and Innovation Programme 3 Manager, presented S2R’s mission and innovations, including the innovative grinding machine developed by Plasser & Theurer within the S2R Programme.

Unife - Boosting railway digitalisation thanks to EU Research and Innovation – 27 April 2021, online

The Executive Director participated in an expert discussion on how rail can use emerging technologies to become the pioneer in sustainable mobility on 27 April.

Organised by UNIFE, as part of the European Year of Rail campaign, the event highlighted the importance of close cooperation with the European institutions for the success of research and innovation in the rail sector.

UNIFE Webinar - Innovative Rail for Sustainable Mobility – 28 May 2021, online

The Executive Director participated to the UNIFE webinar on “Innovative Rail for Sustainable Mobility” on 28 May. He discussed how rail innovation is crucial for the fulfilment of several of the Sustainable Development Goals (SDGs).

The webinar was held in the framework of the OECD International Transport Forum (ITF).

S2R at APTA-UITP Rail Conference – 8-9 June 2021, online

The Executive Director Carlo Borghini participated in the APTA-UITP virtual conference as a panellist in the closing plenary session “The state of rail today and where we are heading”.

This two-day virtual technical conference, organised by APTA and UITP on 8-9 June, featured sessions covering multiple aspects of the rail sector, and explored different rail modes such as high-speed and urban transport.

IPIC – 15 June 2021, online

JU participated in a panel on ‘The fifth transport mode: state of play 2021’ at the 8th International Physical Internet Conference (IPIC 2021) on 15 June. During the event The Executive Director discussed the development of tube transport, pipelines and hyperloop.

The conference provided an open forum for participants from all over the world to discuss global logistics efficiency and sustainability.

Scandinavian Rail Optimisation Online Conference – 24 June 2021, online

The Executive Director spoke about how JU delivers the capabilities to bring about sustainable, cost-efficient, high-performing, time-driven, digital and competitive customer-driven railways for Europe at the Scandinavian Rail Optimisation Online Conference on 24 June.

Western Balkan Rail Summit – 13 September 2021, Belgrade

The Executive Director moderated the Rail Infrastructure panel at the Western Balkan Rail Summit on 13 September.

The summit, organised by the Transport Community, celebrated the European Year of Rail and focused on the integration of the Western Balkans rail system with the EU rail system.

Digital Rail Revolution 2021 – 16 September 2021, online

The Executive Director moderated a panel discussion at the Digital Rail Revolution conference on 16 September.

The panel titled ‘Next steps in delivering digital automatic coupling (DAC)’ discussed how DAC can help to grow rail freight and shift more goods onto tracks.

Rail Broadcast Week 2021 – 13-16 September 2021, online

S2R sponsored a panel discussion as part of Railway Gazette’s Rail Broadcast Week 2021 on 13-16 September.

The Executive Director spoke about the future of Digital Automatic Coupling in Europe with representatives of the International Union of Wagon Keepers and ÖBB.

TRAKO – 22 September 2021, Gdansk

The Executive Director participated in a debate on ‘New technologies, new solutions for the railways’ at the International Railway Fair TRAKO 2021 on 22 September.

TRAKO is Poland’s largest railway fair dedicated to transport systems and railway infrastructure in Europe and around the globe.

World Passenger Festival – 5 October 2021, Amsterdam

S2R Head of Research and Innovation, Giorgio Travaini, participated in a session “Giving the power to our customers: how can digital transformation support a shift to shared and public mobility?” at the World Passenger Festival on 5 October.

The World Passenger Festival in Amsterdam brings together transport leaders to discuss sustainable travel, integrated mobility and customer experience to encourage the use of transport among the general public.

Alpine Rail Optimisation – 6 October 2021, Vienna

During the Conference, on 6 October, S2R Head of Research and Innovation gave a talk titled: “On the way to a new Rail Research and Innovation Programme” where he talked about building the European

future rail concept of operations, what to expect from rail research and innovation during the next years, and migration plans in a view of deployment.

GRITLAB – 7 October 2021, Graz

S2R Head of Research and Innovation, Giorgio Travaini, gave a keynote speech on railway game changer technologies and their impact at the Graz Railway Intelligence Tech Lab in Graz on 7 October.

The event offered masterclasses on pressing topics of the industry, such as digital twin turnouts, switches and crossings, digital twin bogies and digital twin deployment.

Connecting Europe Facility Support for Railways – 14 October 2021, online

The Executive Director spoke at the Connecting Europe Facility Support for Railways event as a panellist during a discussion titled “CEF contribution to the Single European Railway Area (SERA)”.

This event illustrated how CEF has played a key role in the mobilisation of the necessary resources to the successful completion of projects and how these projects have contributed to the provisions of better services to the final users.

European Year of Rail Event in Vienna – 18 October 2021, Vienna

On 18 October during the European Year of Rail Event in Vienna, The Executive Director presented the achievements of JU and the upcoming activities of our successor programme, Europe's Rail.

The aim of the event was to highlight innovative solutions for the environmentally friendly transport mode of rail for sustainable European passenger and freight mobility.

Transport and Logistics 2050 – 21 October 2021, online

The Executive Director delivered an online presentation on 21 October titled "Towards a climate-neutral society: the transformation of the railways".

This international event for transport and logistics presented the latest technological solutions and political issues that will become an essential condition for a competitive business of the future.

Rail Asset Management in Europe – 27 October 2021, online

S2R Innovation Programme 3 Manager, spoke at the Rail Asset Management in Europe conference, about the new Europe's Rail programme, building European intelligent asset management systems, and the outcomes from rail research and innovation in the next few years on October 27.

The conference featured a mix of panel discussions and presentations addressing, among other things, the needs of existing urban rail systems, systems undergoing upgrade or renewal as well as upcoming systems.

SIFER - 26-28 October 2021, Lille

JU took part in SIFER, France's largest rail industry event, in Lille on 26-28 October.

Visitors, including high level representatives from UNIFE and European Commission's Directorate for Internal Market, Industry, Entrepreneurship and SMEs, had the opportunity to meet JU colleagues and take a look at some of our most recent innovative solutions.

S2R Innovation Programme 2 Manager participated to a panel on Europe's Rail objectives and ideas for boosting the EU railway industry with research and development.

Hypermotion Dubai – 2-4 November 2021, online

The Executive Director virtually participated to Hypermotion Dubai. During his intervention, Mr Borghini talked about some of JU success stories, Europe's Rail programme, and how can we expect to see the European rail network evolve over the next decade.

Future of Mobility Forum in Dubai – 3 November 2021, online

The Executive Director participated in a panel discussion at the Shaping the Future of Mobility forum in Dubai discussing "Rail as backbone of multimodality and sustainability in transport" on 3 November.

The Forum highlighted the principles of Sustainable Development, to plan, design and build infrastructures of a more modern, competitive, and resilient country, in line with the principles of the UN 2030 Agenda, the European Green Deal and Italy's National Recovery and Resilience Plan.

Shaping the Future of Mobility – 10-12 November 2021, Lisbon

The Executive Director participated to a panel discussion titled "Innovation and technical challenges of the European transport system" at the Shaping the Future of Mobility seminar on 11 November.

Shaping the Future of Mobility is an international seminar included in the European Year of Rail programme, that took place in Lisbon on 10-12 November.

Belgian Rail Day – 17 November 2021, online

The Executive Director joined a discussion on rail research and innovation at the Belgian Rail Day on 17 November, along with high-level speakers such as the European Commissioner for Transport Adina Valean, Director-General for Mobility and Transport, Henrik Hololei, and the Belgian Minister of Mobility, Georges Gilkinet.

The Belgian Rail Day was co-organised by Europalia, Agoria and FEB. During the colloquium, the speakers discussed Europe's rail ambitions and Belgium's response to the challenges facing the sector.

InnoRail – 16-18 November 2021, Budapest

The Executive Director delivered a video message at InnoRail2021 on 16-18 November, discussing Europe's Rail, JU achievements, and the EU DAC Delivery Programme.

Additionally, Vice Chairperson of JU's States Representatives Group, gave a speech titled "Rail system as a backbone of mobility".

The InnoRail conference is committed to rail transport with the objective of thinking together about the present of rail transport and fostering its future development.

PTFE General Assembly – 17 November 2021, online

S2R Head of Research and Innovation, Giorgio Travaini, participated to the PTFE General Assembly on 17 November. Within the framework of the European Year of Rail, the PTFE focused its debate on national and international R&D&I strategies, the instruments to support the sector and disruptive innovation vectors.

IRSA – 22 November 2021, online

On 22 November, The Executive Director gave a keynote speech on JU's successor, Europe's Rail during the International Railway Symposium Aachen 2021.

During this hybrid event, an international framework for interdisciplinary exchange between industry, science and politics on current and future rail transport topics from research and practice, was provided.

EU for Smart Mobility – 24 November 2021, Warsaw

On 25 November, The Executive Director gave a keynote speech on environmentally friendly transport systems in Europe at the EU for Smart Mobility conference.

He also participated in a panel focused on environmentally friendly solutions such as electromobility, hydrogen mobility and current and future trends and patterns to achieve zero emission in transport.

The conference took place in Warsaw on 25-26 November 2021, and it was organized by the Centre for EU Transport Projects, a governmental entity responsible for implementing EU co-financed transport projects.

RailLive! – 30 November – 1 December 2021, Madrid

S2R had a stand at RailLive in Madrid on 30 November – 1 December where visitors could learn more about JU's Innovation Programmes and our future as Europe's Rail.

On 1 December, our Executive Director took part at the "Investing in, designing and building the rail networks which will provide a connected backbone for mobility of tomorrow" panel. He also delivered a presentation about "Meeting the conditions to double rail freight across Europe by 2030 with digitisation".

A presentation on "Designing, testing and implementing the critical control systems of the future" was given by S2R Head of Research and Innovation.

During the event, the Minister of Development, Infrastructures and Regional Planning of the Junta de Andalucía, Marifran Carazo, and the Mayor of Málaga, visited our stand and discussed with The Executive Director on a possible collaboration with the region.

Second Smart Rail Technology Conference – 30 November 2021, online

The Executive Director took part in a panel titled "HYDRAIL: Strategic economic and environmental drivers behind the hydrail phenomenon" on 30 November.

CUTRIC hosted its second Smart Rail Technology Conference virtually on November 30 – December 1 to discuss critical topics that will define the future of rail in Canada.

UIC Symposium – 30 November 2021, online

The Executive Director participated to a panel on “Digital game changers in the next 5 years?” and talked about the transition to clean mobility at the UIC Symposium 2021 on 30 November.

UIC held a symposium on The Future of the Railways: Making Modal Shift Desirable on 30 November - 1 December at its headquarters in Paris.

UNIFE webinar “Enabling digital and intelligent rail freight in Europe” – 7 December 2021, online

The Executive Director highlighted the need to focus on emerging technologies at the UNIFE webinar “Enabling digital and intelligent rail freight in Europe” on 7 December.

Organised by UNIFE as part of “The European Year of Rail” campaign, this event was an opportunity to assess the importance of rail freight for reaching the European Commission’s climate and digitalisation targets with high level representatives from the European Parliament, the European Union Agency for Railways (ERA), Siemens Mobility and Wabtec.

ICT for Railway workshop in – 7 December 2021, Toulouse

S2R Cross-Cutting Activities Manager participated to a panel discussion on Strengthening European Railway Competitiveness at the ICT for Railway workshop in Toulouse, France on 7 December.

The discussion focused on the role of standardisation in innovation. Standardisation and regulatory path need to be developed in one common strategy with research in order to ensure proper and quick market uptake of solution. The Europe’s Rail System Pillar will ensure this major step-change.

2.1.2. Communication

Website

In 2021, the JU website was enhanced with new content. A dedicated area of the website was created reporting on the latest results coming from our projects, as well as a page on statistical information showing the progress of the S2R programme. Additionally, with the launch of the JU successor programme, several new pages were created containing information about the new Europe’s Rail Joint Undertaking. The new pages are ‘About EU-Rail’, ‘Mission and objectives’, ‘Europe’s Rail organisation’, ‘Europe’s Rail Reference Documents’, Europe’s Rail Key Documents, Europe’s Rail Annual Work Plan and Budget, Europe’s Rail Annual Activity Report, Europe’s Rail Annual Accounts, Functioning of the Europe’s Rail JU, Europe’s Rail Governing Board, Europe’s Rail Scientific Committee, Europe’s Rail JU Members, Europe’s Rail Structure of Governance, Europe’s Rail Executive Director, and Europe’s Rail States Representatives Group.

These developments were mostly done in-house at short notice to meet needs in an efficient manner.

Additionally, in January 2021 a web development contract was launched with our communication framework contract to develop a new event landing page and individual event page. This development significantly improved the visibility of our events calendar by making it more prominent. Design features of these pages were also improved making the content visually appealing. Furthermore, the website’s responsiveness was improved taking into account the new content published over the past two years. The main menu was revamped ensuring that menu items display in a much more coherent manner. The update was done for desktop, mobile and tablet users. Also, the main landing page

banner's responsiveness was improved to ensure that content displays correctly for mobile phone and tablet users.

A full website revamp is foreseen in 2022.

R&I content

Significant efforts and improvements have been made on the R&I content that a user can get from the S2R website. In January 2021 a new webpage titled 'Latest results' was launched. The new webpage summarises information about key deliverables and results coming from JU projects during the respective month. It allows visitors to access key information about JU results without needing to read the full deliverables. In addition to that, in June 2021 a webpage titled 'Programme progress' was created. The webpage allows our visitors to learn about progress of our Innovation Programmes, and at what stage the development of our technical demonstrators is. The webpage is updated on a monthly basis.

Data protection

In cooperation with the ICT Officer, the Chief Legal Officer, who is the JU's Data Protection Officer, and two contractors managing the shift2rail.org and projects.shift2rail.org domains, Shift2Rail's communication team continued to work on making the website compliant with the data protection regulation based on the instructions provided by the European Data Protection Supervisor. In 2021 we created a database for "online consent" and GDPR with automatic process that allows to unfollow/delete data. We ensured that the website platform and applications are compliant with the GDPR and EUDPR Regulations. In particular, our contractor ensured that a privacy management platform is used. Furthermore, the website cookie management was improved. All passwords were encrypted and a more secure method with unique hashed key and frequent backup was developed. A backup content database that is not on the same server as the website was created.

As a result of this work, JU's website is considered compliant with the data protection regulation that also helped the domain to substantially improve its position in the EU Privacy Score Tool.

It is also worth mentioning that in 2021 a security audit was performed by CERT-EU and all security recommendations were applied.

User statistics

JU's website was visited by 129,197 unique visitors in 2021, which is a significant increase compared to 91 073 unique visits in 2020. Most visitors (81,962) were based in Europe, followed by North America (31,072 visitors) and Asia (13,672 visitors). The largest number of visitors by country were based in the United States, followed by Belgium, Germany, the United Kingdom, France, Spain and China. JU's website was mostly visited by people using a personal computer (115,009 visitors), second most popular device being smartphone (12,772 visitors). A low bounce rate (24%) on the JU website indicates that visitors find the website content interesting and informative. Average time spent on the JU website in 2020 was 2,5 minutes.

Newsletter

In 2021, JU's Communication Team continued fully managing the production of the monthly newsletter, without relying on an external contractor, which has significantly improved efficiency and

the team's flexibility in being able to respond to last minute news input from colleagues and external parties. The monthly newsletter offers readers an overview of the most important news and events, while giving visibility to our projects.

The 2021 editions continued to include more project news and results deriving from the Projects Communication Spreadsheet that is filled in by project coordinators and partners themselves. Additionally, a dedicated section in the newsletter on project results was created to further enhance their visibility. This activity is successfully intertwined with the new website page on project results, therefore, giving it increased visibility on a monthly basis. Additionally, 2021 saw an increase of articles per newsletter. The average number of articles per newsletter has increased to 26 in 2021, in comparison to 10 in 2020, a major increase of over 100%, clearly showcasing the increasing involvement of S2R in various activities in Europe and beyond.

The readership of the JU newsletter has steadily increased throughout the year from 1,576 in January 2021 to 1,767 at the end of 2021, reaching +13%. Various factors have fed into the growth of the audience including JU's participation to numerous events, improvements to the JU website offering more visibility to the newsletter, more promotion of the newsletter by staff through their meetings and networks, and increased promotion of the newsletter and its individual articles on JU's corporate social media channels, and of course the increased interest during the European Year of Rail.

Social media

In 2021 due to the European Year of Rail the JU increased its online presence significantly and dedicated time and resources to improve the content and frequency of its posts across its social media accounts – Twitter, LinkedIn, Facebook, YouTube – to engage with the rail community. In 2021, S2R Communication Unit introduced lighter content on its social media channels in order to attract broader audiences interested in European Year of Rail, while of course also continuing to promote R&I results coming from the programme. One such example is the coverage of the Connecting Europe Express, where S2R posted about involvement of young people in the rail industry, news from each stop, photos of exhibition visitors, therefore, bringing the content much closer to the European citizens. During 2021 S2R JU has been aiming to constantly inform the already converted, while also reaching out to new interested stakeholders, in order to ensure a growing audience for JU activities. In 2021, the average number of tweets per month was 44, while in 2020 the average number was 35, showing a significant increase in social media activity.

The audiences JU targets on social media depend on the channels. While on Twitter JU is followed by a wide audience with different backgrounds, LinkedIn attracts a more specialised community interested rather in technical details and longer in-depth articles. JU's Communication Team creates different content in order to tailor the message to these different audiences. On Twitter JU shares daily events, short articles and posts illustrated with images and videos. On LinkedIn, however, the audience expects longer, more thought-provoking material including technical details about our innovations. 2021 saw a major growth in terms of LinkedIn popularity, proving it to be the most viewed social media channel of S2R JU.

JU has also increased its presence on its YouTube channel. Efforts have been made to publish videos showing our innovations as well as recordings of our online events to ensure that even those who were unable to join, have access to the content. JU's YouTube account grew significantly due to the European Year of Rail video developed together with DG MOVE, which amounted to over 40k views, therefore, also attracting new audiences.

JU has increased the number of followers on all its social media channels during 2021. The largest increase in the number of followers was on LinkedIn where JU got an impressive 2,400 new followers.

The total number of followers on LinkedIn is now 6,556. LinkedIn therefore has the biggest audience out of all JU's social media channels. On the other hand, JU's Twitter account has 4,175 followers out of whom 695 started following the JU account in 2021.

Throughout 2021, the JU has put more effort into long term social media planning to make sure that all relevant news is promoted through our social media platforms in a timely and effective manner. JU also focused in 2020 on engaging more intensively with other relevant stakeholders on social media (DG MOVE, DG RTD, CINEA and other EU-institutions; Members and key associations) that help to support the dissemination of JU messages and vice-versa. We have had an especially successful collaboration with DG MOVE who have posted and re-shared JU content on their Twitter account, which has 50,000 followers. This collaboration has been very much intensified in 2021 to promote the European Year of Rail and its flagship campaign the Connecting Europe Express.

Just like in previous years, in 2021, JU also had at the heart of its strategy the promotion of JU project results through its social media channels (see also section 1.1. Dissemination and information about projects results). Thanks to the collection tool developed by JU, projects are able to directly propose content for organic or re-shared posts, through the Projects Communication Planning Sheet. This has proved a successful tool in providing fresh and up-to-date content to fuel S2R channels, allowing an increase in the number of posts and a larger visibility to our audience concerning what is happening on the ground to build the rail solutions of the future. The new webpage promoting project results has also added to the success of social media content as it provides more interesting content to our followers, summarising the latest results coming from the S2R R&I programme.

Additionally, in December, in the frame of the launch of the S2R successor programme Europe's Rail, all social media handles were changed to make reference to the new programme. Therefore, the new social media handles are as follows:

- Twitter: @EURail_JU with the following link: https://twitter.com/EURail_JU
- LinkedIn: @Europe's Rail Joint Undertaking with the following link: <https://www.linkedin.com/company/eu-rail-joint-undertaking>
- Facebook: @Europe's Rail Joint Undertaking with the following link: <https://www.facebook.com/europesrail>
- YouTube: Europe's Rail Joint Undertaking with the following link: <https://www.youtube.com/c/EuropesRailJointUndertaking>

Press

JU published eight press releases in 2021, covering the Shift2Rail 2021 Call for Proposals, the launch of Europe's Rail Joint Undertaking, JU's hackathon Hack2Rail, the signing of Memorandums of Understanding with CEN and CENELEC and UIC, the European DAC Delivery Programme and collaboration with EUSP (full details of all press releases are available in Annex E).

In 2021, the S2R JU was featured in articles in a range of magazines, industry press and online media. JU's Communication Team has continued to build relations with journalists and editors from different media outlets to find ways for cooperation and offer ideas for stories. JU's Communication Team has created a directory of over 100 journalists who often publish JU related content. Additionally, we have developed an especially fruitful collaboration with journalists from the Railway Gazette, International Railway Journal, RailTech, Global Railway Review and Railway Pro. Journalists from EuroNews have reached out S2R on several occasions to hear our input in terms of the European Year of Rail.

In addition to JU's news about the launch of Europe's Rail Joint Undertaking, some of the most widely covered stories about JU include the launch of the Call for Proposals 2021, the various MoUs signed in 2021 and JU's role in the European Year of Rail, especially the flagship initiative the Connecting Europe Express. Various articles about JU featured in the media in 2021 were popular and these have been monitored and archived as well as featured in the monthly JU newsletter.

In 2021, journalists have also been targeted by JU on social media which has proved effective as well. The fact that the Programme continues to become better known and the interest in its results progressively increases is reflected in a broader media coverage of JU compared to previous years.

2.2. Legal and financial framework

In 2021, the S2R JU legal framework refers predominantly to:

- Council Regulation (EU) N°642/2014 of 16 June 2014 establishing the Shift2Rail Joint Undertaking (OJ L 177, 17.6.2014, p. 9)³¹,
- The Delegation Agreement between S2R JU and the EC,
- The General Financial Regulation (EU, Euratom) 2018/1046³², subject to any specific provisions of the Financial Rules of the S2R JU and the establishment act,
- The Financial Rules of the S2R JU³³, adopted by the Governing Board Decision N° 11/2019 of 20 December 2019³⁴ and entering into force on 1 Jan 2020,
- The S2R JU GB Decisions adopted since its establishment, which frame the functioning of the S2R JU within the boundaries of the S2R Regulation and its Financial Rules, in particular the AWP to be approved by the GB (draft budget, Staff Establishment Plan, Scientific Priorities, calls, tenders, etc.). As indicated in the GB rules of procedure, once adopted the GB decisions are published on the S2R JU web site³⁵.

In addition:

- Regulation (EU) No 1291/2013 of the European Parliament and of the Council of 11 December 2013 establishing Horizon 2020 — the Framework Programme for R&I for the period 2014-2020 and repealing Decision No 1982/2006/EC (OJ L 347, 20.12.2013, p. 104), as well as Regulation (EU) No 1290/2013 of the European Parliament and of the Council of 11 December 2013 laying down the rules for participation and dissemination in Horizon 2020 (OJ L 347, 20.12.2013, p. 81) is applicable to the grants awarded by JU;
- The Staff Regulations of officials and the conditions of employment of other servants of the European Union are applicable to the staff of the JU.

Additional reference documents may be found on the JU's dedicated webpage: <http://shift2rail.org/about-shift2rail/reference-documents/>.

³¹ <https://eur-lex.europa.eu/legal-content/EN/TXT/?uri=CELEX:32014R0642>

³² Regulation (EU, Euratom) 2018/1046 of the European Parliament and of the Council of 18 July 2018 on the financial rules applicable to the general budget of the Union, amending Regulations (EU) No 1296/2013, (EU) No 1301/2013, (EU) No 1303/2013, (EU) No 1304/2013, (EU) No 1309/2013, (EU) No 1316/2013, (EU) No 223/2014, (EU) No 283/2014, and Decision No 541/2014/EU and repealing Regulation (EU, Euratom) No 966/2012. OJ L 193, 30.7.2018, p.1.

³³ By Delegated Regulation (EU) 2019/887, the Commission adopted the model financial regulation for public-private partnership bodies to ensure sound financial management of Union funds and to enable public-private partnership bodies like S2R JU to adopt their own financial rules. The model financial regulation should be consistent with the provisions of Regulation (EU, Euratom) 2018/1046. The S2R JU shall adopt its financial rules in accordance with this model financial regulation.

³⁴ <https://shift2rail.org/wp-content/uploads/2020/01/S2R-JU-Financial-Rules.pdf>

³⁵ <https://shift2rail.org/about-shift2rail/structure-of-shift2rail-initiative/governing-board-2/>

As indicated in the cover page of this AAR, in accordance with Council Regulation (EU) 2021/2085 (the “SBA”) the EU-Rail is the legal and universal successor of the S2R JU, which it replaced and succeeded as from 30 November 2021.

To ensure the business continuity of the operations, the first Governing Board of EU-Rail approved the list of decisions³⁶ adopted by the S2R JU that continues to apply for the EU-Rail in accordance with Article 174(12) of the SBA. This list includes decisions concerning aspects related to governance, human resources, finance, audit and internal controls and compliance, and in particular the Financial Rules of the JU. The Executive Director also approved the list of decisions adopted under S2R JU that will continue to apply to EU-Rail. Additional reference documents may be found on the EU-Rail JU’s dedicated webpage: <https://shift2rail.org/about-europes-rail/europes-rail-reference-documents/>.

As regards the Framework Programme for Research and Innovation, [Regulation \(EU\) 2021/695](#) of the European Parliament and of the Council (the ‘Horizon Europe Regulation’) establishes the new policy and legal framework for European partnerships.

2.3. Budgetary and financial management

At yearend 2021, the JU had implemented 100% of its commitment appropriations made available in its active budget (Titles 1 to 3). The payment appropriations were implemented up to 85% of the active funds. The implementation, when compared to the full JU budget (including Title 4), was 100% in commitment and 63% in payment appropriations.

By means of the GB Decision 08/2020 of 7 December, the JU Governing Board adopted the initial Annual Work Plan and Budget for 2021. The document was subject to two amendments adopted in 2021. Both amendments aimed at maximizing the performance and impact of the JU. For more information about the two budget amendments, please refer to the Section 1.7 of the present document.

Following this, the active JU budget available for 2021 amounted to kEUR 13.625 in commitment appropriations and kEUR 68.440 in terms of payment appropriations.

Title	Commitment appropriations (including reactivations)				Commitments made	EUR '000
	Initial budget adopted and additional appropriations	Amending budget	Transfers	Final adopted budget		%
	(1)	(2)	(3)	(4)=(1)+(2)+(3)		(6)=(5)/(4)
1	2 510	(108)	15	2 417	2 417	100%
2	1 557	103	(16)	1 644	1 644	100%
3	9 564	0	0	9 564	9 564	100%
Total	13 631	(5)	(0)	13 625	13 625	100%
4	0	0	0	0	0	0%

³⁶ EU-Rail GB Decision n° 02/2021. The list is available at: https://shift2rail.org/wp-content/uploads/2021/12/GB-Decision_02-2021_Omnibus_Annex_list.pdf

GRAND TOTAL	13 631	(5)	(0)	13 625	13 625	100%
--------------------	---------------	------------	------------	---------------	---------------	-------------

Title	Payment appropriations (including reactivations)				Payments made	EUR '000
	Initial budget adopted and additional appropriations	Amending budget	Transfers	Final adopted budget		%
	(1)	(2)	(3)	(4)=(1)+(2)+(3)		(6)=(5)/(4)
1	2 617	(152)	0	2 465	2 371	96%
2	1 083	83	0	1 166	1 088	95%
3	64 352	(17 669)	0	46 683	39 417	84%
Total	68 052	(17 738)	0	50 314	42 877	85%
4	567	17 559	0	18 126	0	0%
GRAND TOTAL	68 619	(179)	0	68 440	42 877	63%

Title 1 and Title 2 of the JU Budget were executed up to 100% in commitment appropriations, demonstrating a reliable budgetary planning.

Title 1 - Staff Expenditure was mainly used for the salaries of the JU staff. During the year, the JU made also use of external support, to fill the gaps during the recruitment process following from the staff turnover and to cope with the important workload on JU activities.

The implementation rate of the payment appropriations was 95% (96% in 2020), showing a steady implementation trend in relation to the previous budgetary year and demonstrating the JU's ability to react to changing circumstances in 2021.

Due to the Covid-19 crisis, a significant part of the budget for missions was reallocated to support digital meetings and events, enhancement of digital services to support staff and the implementation of a specific training programme to accompany the staff in such a critical period. The Executive Director has executed his rights in accordance with Article 10 of the EU-Rail Financial Rules and reallocated these funds to answer the specific needs of the JU for the year. In addition, the payments related to the Press & Information budget were not executed due to the rescheduling of events (e.g.: TRA and Innotrans, etc.). The events have been postponed to 2022.

Title 3 Operational Expenditure

Title 3 constitutes the JU's Operational Budget. The majority of the JU's budget falls under this category representing 70% of the active (Titles 1 to 3) and overall budget (including Title 4). The proportion has decreased in 2021 since only EUR 9,6 million was available to be allocated to operational commitment appropriations this year, being the final year of the launch of activities under the S2R Programme. The budget category covers the JUs last Call for proposals under H2020 MFF, operational procurement and expert fees incurred as part of the evaluation.

The implementation rate of the operational budget in both commitment and payment appropriations was 100% and 84% respectively (80% in 2020). This year, only a minor portion of payment appropriations were used for the pre-financing of the grants resulting from the 2021 Call for proposals.

The reported implementation also includes kEUR 48 relating to the Expert Evaluators which is managed by the REA Services.

Title 4 Unused appropriations not required in current Year

The amount included under Title 4 – Unused appropriations not required in current year - has been established to support a transparent implementation of JU Financial Rules, in particular their Article 6.5, the so-called n+3 rule. In accordance with the Financial Rules and the general practice of the JU, these appropriations will be reactivated in the future year budget(s) and used first in the that year.

More than kEUR 17.500 of unused operational payment appropriations has been transferred to Title 4.

After this transfer, the total unused appropriations available of kEUR 626 of unused administrative payment appropriations and kEUR 17.500 of unused operational payment appropriations, recorded under Title 4 in EU-Rail budget 2021, have immediately been re-allocated to the EU-Rail budget 2022 in accordance with the GB Decision 02/2021 of 21 December 2021 (Omnibus Decision), adopting the Annual Work Plan and budget for 2022.

2.4. Procurement and contracts

In order to reach its objectives and adequately support its operations and infrastructures, the JU continued in 2021 to allocate funds to procure the necessary services and supplies. In the interest of sound financial management and to the possible extent, the JU made use of Service Level Agreements (SLAs) with relevant Commission services and EU Agencies (ICT, training, payroll, mission, experts reimbursements, interim staff, etc.) and participated in inter-institutional framework contracts (e.g.: IT, audit, office furniture, insurance, human resources services) by signing Memoranda of Understanding. In addition, the JU led or participated in inter-JUs framework contracts (e.g.: IT and data protection services), also with the objective to enhance synergies.

In 2021, the JU implemented the following framework contracts (FWCs) awarded at the end of 2019: Provision of integrated information and communication campaigns, event organisation and public affairs services. This FWC was not renewed and therefore was terminated in December 2021. To ensure synergies between the JUs, a common open tender procedure (Multiple Framework Service Contract in cascade-4 lots) for communication services was launched between Clean Sky 2, S2R and SESAR Joint Undertakings. The award of the framework contracts is scheduled in the first quarter of 2022.

When SLAs or a FWCs were not available for specific services or supplies, the JU resorted to middle and low-value contracts.

In accordance with Article 15 (Principle of transparency) of the JU financial rules, requiring that the JU shall make available on its internet site no later than 30 June of the following financial year information on the recipients of funds deriving from its budget; the procurement contracts awarded in 2020 were published in the “Recipients of Shift2Rail Funds and Annual List of Specific Contracts” at the following web page: <https://shift2rail.org/participate/recipients-shift2rail-funds/>.

In the same page, in accordance with point 3.3 of the Annex I of the Financial Regulation 2018/1046, the JU, as a contracting authority, published the list of specific contracts under awarded based on framework contracts.

In order to establish the maximum values of procurement contracts, where necessary, the JU makes use of the collective experience of its staff involved in it, its Members and experts as necessary, driven by the principle of sound financial management. Although this was not formally documented in formal acts, audit trails are available also in the exchanges between the staff and the procurement sector to finalize the call for tenders before approval by the Executive Director.

In 2021, for open procedures, the JU continued using the e-tendering and the e-submission platform available from the TED e-Tendering website and accessible on the Funding and Tenders Opportunities portal³⁷. The target is to extend e-tendering and e-submission to other types of tender procedures (i.e.: restricted and middle-low value tender procedures) and other IT tools (i.e.: e-ordering and e-invoices).

During 2021 several guidance documents and templates for procurement procedures continued to be updated by the Chief Legal Officer (i.e.: calendar, tender specifications, opening and evaluation of tenders, award procedures for low value contracts, etc.) to adapt them to JU needs and to the DG BUDG recommendations, in particular to the e-submission procedure. In addition, the register of framework contracts, SLAs and Memoranda of Understanding has been regularly updated to ensure a proper follow-up of the SLAs and FWCs in force.

In 2021, a new register of procurement contracts was created and built from ABAC legal commitment (LCK). This new “e-contract register” records all JU legal commitments (i.e.: “procurement contracts and grant agreements”) and is also the basis for publication of the “Annual S2R JU Recipient of Funds, including all specific contracts implementing framework contracts” information in its website. The register also allows the monitoring of the JU’s consumption of FWCs.

2.5. IT and logistics

The JU focus was on the core activities: since its creation, the JU has been one of the most active promoters of a single approach for all the JUs to the ICT environment, reducing costs, outsourcing, and increasing performance.

In this respect:

a. Use of European Commission applications and framework contracts

The JU has implemented common ICT tools designed and made available by the EC for the financial management and Horizon 2020 call management. These tools are updated and maintained on regular basis by the EC; they require continuous input from the side of the JU, on the one hand, to correct the multiple and repetitive mistakes and, on the other hand, in terms of future developments to meet the expectations of the partnership. The follow-up of these processes absorbs multiple resources of the JU.

In order to ensure the correct usage and implementation of these applications, JU makes use of the training services offered by the EC on these applications.

³⁷ <https://ec.europa.eu/info/funding-tenders/opportunities/portal/screen/home>

For the execution of the call for proposals in the AWP 2020, the Horizon 2020 IT systems were used throughout the entire process: for the publication of the call, for the submission and evaluation of the proposals as well as for grant preparation. The EC IT systems “e-submission”/ “e-tendering” have also been used for the first time in 2020 for one of the JU operational tender procedures.

In addition to the extended use of the Commission financial applications, the JU adopted the EC's ICT systems for HR (Sysper) and daily document management (ARES) to leverage the EC's proven working technology solutions already in place, but also to streamline and further harmonize the processes, workflows, procedures of record management, document archiving and electronic document cataloguing, secure storage and document access.

The JU continued to make use of the Commission's ICT framework contracts to procure all ICT services required to run its activities.

b. Use of European Agencies' framework contracts, including with or on behalf of other JUs

In addition, EU-Rail participates to the joint strategic ICT plan of the JUs located in the White Atrium building. Since 2018, the EU-Rail shares its virtual IT infrastructure that is hosted by a private cloud computing provider and also shares the ICT managed services performed by a private company, in synergy with these other JUs. In 2020, the connectivity to the EC tools has also been migrated to this private cloud, which provides a full mobility and independence from the EU-Rail premises and confirmed as efficient during the Covid-19 pandemic. In 2020 and 2021, EU-Rail has also further integrated other agencies to benefit from these services, such as ERA, ELA, BEREC, etc., building upon a unique know-how of synergies' service model.

In 2020, on behalf of all the JUs, the JU commissioned a Data Protection Impact Assessment (DPIA) and security risk assessment on the migration to Microsoft Office 365 public cloud environment, as required by the adopted EU regulation on the protection of personal data by EU institutions and bodies (Regulation (EU) 2018/1725). The DPIA identified the inherent risks that can be mitigated through a series of identified measures with the conclusion that the residual risks are qualified as “under control”. Along with the progressive implementation of these mitigating measures, the EU-Rail started in 2021 to migrate to Office 365 in synergy with the other JUs, first to Teams, then to SharePoint and OneDrive. The next Office 365 asset to be migrated in 2022 is Exchange online as well as the document libraries in SharePoint. The mitigating measures and migration for the other assets will be implemented in 2022.

2.6. Human Resources

In 2021, the JU dealt with recruitment of staff members to replace the departing ones, in particular the following: the Internal Control Coordinator, one Programme Manager (in both cases, the former staff members left for inter-agency mobility), the Administrative Assistant to the R&I Unit, the Communication Officer, and one Seconded National Expert who terminated her secondment.

The JU also made use of a contract agent(s) to replace one TA on long-term absence in order to ensure the continuity of operations, after also having distributed some parts of her agenda to other staff, while complying with the need of segregation of duties.

At the end of 2021, the JU team as per its Staff Establishment Plan was comprised of 23 posts (see ANNEX B)³⁸; the new staff establishment plan associated to Europe's Rail was subject to approval by the Governing Board of the AWP, which required the opinion of the SRG not yet constituted by the end of 2021. Hence, it will enter into force as soon as adopted.

Moreover, for the fifth year, the JU welcomed Bluebook Trainees in accordance with the SLA signed with DG EAC.

In addition to recruitment activities, the JU HR Officer ensured the conduct of day-to-day personnel-related administration not covered by the Commission central services. Particular attention was also given to the swift implementation of HR-related decisions adopted by the JU GB (Implementing Rules).

In 2021, the JU continued to implement the action plan drawn up to address the key aspects resulting from the 2020 staff survey. This action plan resulted in three main responses:

- a. the "wellbeing training programme" to accompany the staff at personal and professional level during the pandemic situation;
- b. a dedicated training programme to redefine the "bond" between the staff at all levels, focusing on three main concepts "Perform (deliver) – Inspire (people) – Engage (stakeholders)" that has been running till summer 2021 and impact of which will be re-assessed during the second staff survey;
- c. a dedicated assessment of the processes and procedures put in place to run the Programme in view of the launch of S2R's successor, engaging also with the S2R industry members.

Furthermore, the fifth reclassification exercise of the JU was successfully carried out during 2021.

Due to the Covid-19 outbreak, the JU was unable to organize team-building activities as usual. However, in order to provide the staff with an adequate support to best address the new challenges following from the pandemic, the JU continued to propose a wellbeing programme to the staff. The program was developed by the winning contractor of lot 2 "HR activities" of the Framework Contract N°HR/R1/PO/2019/024. This program started at the end of 2020 and was deployed also in 2021, including different activities such as webinars on psychological and physical wellbeing, meditation exercises, mindfulness, individual coaching sessions etc.

2.7. Data protection

The JU continued to implement the EU data protection policies and legal framework. As regards the processing of personal data, the JU applied the current EU Data Protection rules (Regulation (EU) 2018/1725³⁹) that entered into force on 11 December 2018. In particular, the JU Data Protection Officer (DPO) followed the recommendations and guidance provided by the European Data Protection Supervisor (EDPS), attended the different data protection meetings and networks, coordinated his work with the other DPOs and provided guidance to JU staff on data protection issues.

To ensure compliance with the data protection principles and synergies with the other Joint undertakings (JU), the JU took the following actions:

- as a "leading contracting authority":

³⁸ Due to ongoing/pending recruitments, on 31/12/2021 there were 19 staff members including 1 SNE available.

³⁹ Regulation (EU) 2018/1725 of the European Parliament and of the Council of 23 October 2018 on the protection of natural persons with regard to the processing of personal data by the Union institutions, bodies, offices and agencies and on the free movement of such data, and repealing Regulation (EC) No 45/2001 and Decision No 1247/2002/EC.

- continued the monitoring of a common inter-JU central on-line register of records of activities processing personal data (article 31(5) Regulation (EU) 2018/1725) tailor made to the needs of the JUs.
- coordinated an inter-JU data protection impact assessment (DPIA) and action plan for the migration to Office 365 and implemented the JU individual mitigating measures proposed in the DPIA;
- coordinated a common template for implementing rules concerning the DPO function.
- continued representing the other JUs in a working group on “Joint Controllership” within the Research & Innovation Family for personal data processing operations in the "Funding and Tenders Portal".
- closely followed up on the introduction of a “joint controllership” clause and a joint controllership arrangement (Article 28(1) of Regulation 2018/1725) in the replacement of the standing SLAs with the European Commission.
- continued to update privacy policies and the central data protection register (<https://shift2rail.org/dpreister/>) in order to provide transparent information, communication and modalities for the exercise of the rights of the data subjects (Articles 14 to 16 of Regulation (EU) 2018/1725).

In 2021, the DPO started the drafting of the JU Data Protection Action Plan with the assistance of an external contractor. The finalisation of the Action Plan is foreseen in second quarter of 2022. As in the previous year, the role of the DPO was exercised in 2021 by the JU’s Chief Legal Officer. At the end of 2021 the DPO organised, with the assistance of an external contractor, a general data protection awareness session to JU staff.

3. GOVERNANCE

3.1. Governing Board (GB)

In accordance with the S2R Regulation, the JU GB continued its work steering the JU through the adoption of decisions to be implemented and executed by the ED. Three meetings of the JU Governing Board were convened in 2021. The 27th meeting was convened as an informal meeting due to lack of availability of the Chair and Co-Chair of the Board. These GB meetings dealt with both operational and administrative aspects. Important decisions were taken, such as the approval of the list of actions proposed by the ED selected for funding under the 2021 Call for Proposals, the adoption of the Financial Annual Accounts 2020, the adoption of the AAR 2020 and the AWP 2022, the amendment to the AWP 2021, and the decision on the non-award of the Inducement Prize.

The Governing Board decided to take a decision on the non-award of the inducement prize launched based on the AWP 2020 under the Horizon2020 rules of participation. The decision endorsed the result of the evaluation of the jury that had decided not to select any of the finalist applications. The JU Governing Board decided to reallocate the price budget of 500 000 EUR to the framework contract on ERTMS.

The Executive Director regularly reported to the JU Governing Board about the programme and communication activities under the Shift2Rail Joint Undertaking, overseeing the projects, informing about the JU-supported events (e.g. European Year of Rail 2021, Connecting Europe Express, Hack2Rail Hackathon, S2R Research and Innovation Days 2021), and updating the Board on the DAC delivery programme and activities of the ED Programme Board. The Executive Director regularly provided updates on the preparatory work to establish Europe’s Rail Joint Undertaking and on the status of the Single Basic Act negotiations.

The JU Governing Board was informed that the Shift2Rail Joint Undertaking signed Memoranda of Understanding with CUTRIC (as reported in the AAR 2020), CEN/CENELEC and UIC. The Governing Board was also informed about the Cooperation Agreement signed with the Permanent Secretariat of the Western Balkan Transport Community (as reported in the AAR 2020).

The Executive Director informed the JU Governing Board about the note received from DG BUDGET on the termination of DG BUDGET's accounting services performed for the Joint Undertakings. The JU Governing Board provided Executive Director with a mandate to explore different solutions and alternatives to the DG BUDGET's services.

In terms of KPIs, the participants to the Governing Board were informed about the recommendations on the KPI exercise to Europe's Rail Joint Undertaking as requested by the ED Programme Board in March 2021. The Governing Board was also informed about the annual KPI status with specification of KPI targets in LCC, capacity and punctuality.

Given the adoption of the Horizon Europe Regulation, the opportunities for the railway community emerging from the Horizon Europe framework were presented to the JU Governing Board (e.g. European Research Council, Maria Skłodowska-Curie Actions, and European Innovation Council).

The changes of the legal status of the JU members were reported to the GB, in particular regarding:

- the takeover of Bombardier by Alstom,
- the takeover of SIRT I by MER MEC.

With the gradual progress in activities leading to adoption of the SBA (it came into force on 30 November 2021) more and more focus was given also on the establishment of the new JU bodies. With regard to the Governing Board of EU-Rail, due attention was given to collecting the declarations of interests as well as the CVs of the new GB members and their publication on the JU website, as required in the JU Financial Rules. While experiencing some issues with fulfilling this requirement with regard to the S2R Governing Board, a significant improvement in this respect was achieved with the new GB⁴⁰.

The first Governing Board meeting after the Europe's Rail Joint Undertaking became operational was convened in December 2021. Two decisions were taken, the first one being the adoption of the Rules of Procedure of the JU Governing Board, and the second one being approval of the list of GB decisions adopted by the JU that shall continue to apply for EU-Rail (the "Omnibus decision").

In this first GB meeting, the Executive Director informed the Governing Board about the proposal of the organizational chart for the Europe's Rail Joint Undertaking. The formal decision adopting the organizational chart has been taken by the Governing Board in its meeting of 1 March 2022.

The Governing Board was also informed about the Article 87(2) of the Single Basic Act that provided a ground for selection of associated members from a list drawn up after an open call for expression of interest launched by the Commission. The Executive Director informed the Board about the entities possibly concerned by the matter. The Executive Director underlined that the Governing Board may decide to take a decision on triggering Article 87(2) by the end of May 2022 in accordance with the Single Basic Act provisions.

⁴⁰ At the time of drafting of this AAR, all the declaration of interests from the GB members other than the Union have been received and published in the JU website, while only one CV was missing from one GB member other than the Union.

3.2. Executive Director (ED)

According to the S2R Statutes, as well as according to the SBA applicable as of 30 November 2021, the ED is the Chief Executive Officer responsible for the day-to-day management of the JU in accordance with the decisions of its GB and being accountable to the GB. The ED is the legal representative of the Joint Undertaking. He is supported by the JU staff organized in the Programme Office.

The JU ED was appointed on 16 February 2016. He took up his duties on 16 May 2016.

During the 26th GB meeting of 19 November 2020, the Chair informed the Board that it has launched its internal procedure in view of the extension of the term of office of the Executive Director. The JU Governing Board endorsed this extension, renewing his mandate until 15 May 2026. The Executive Director informed the Governing Board that the process for recruiting his successor should be launched 2 years in advance.

Under Shift2Rail Joint Undertaking, the ED has been supported by the Head of R&I and the Head of Finance and Administration. The Programme Office under his responsibility followed, in 2021, the Governance and Process Handbook which describes in detail the processes and procedures to monitor the performance of the projects that will be implementing the Programme through an integrated Programme Management approach. For EU-Rail, changes are to be introduced to the JU organizational structure. However, the design of reporting lines applied for the JU will continue to apply also for EU-Rail.

Furthermore, 2021 saw the consolidation of the ED Programme Board, striving to ensure that barriers experienced in the integration of new concepts in the S2R R&I activities are duly addressed, as well as to ensure that a more encompassing future system architecture would not find obstacles in their integration in the specific R&I projects.

3.3. States Representatives Group (SRG)

By the end of the S2R Programme, 33 countries had nominated representatives to the Shift2Rail Joint Undertaking SRG. During 2021, the JU SRG held four meetings and one informal meeting.

The fourteenth meeting of the SRG took place in March 2021. The SRG approved in written procedure the extension of mandates of the incumbent Chair and Vice Chair of the Group until the launch of the Europe's Rail Joint Undertaking. The SRG was updated on the European DAC delivery Programme. The Executive Director invited the SRG to appoint Member States' representatives to the SRG-DAC subgroup. The SRG also discussed the opportunities of using the EU schemes to invest in railway technologies.

The SRG discussed in detail and provided Member States' feedback on the Master Plan of Europe's Rail Joint Undertaking during its informal meeting in March 2021.

During its fifteenth meeting in May 2021, the SRG was informed about the extension of the Executive Director's mandate until May 2026. The Executive Director informed the SRG about the call for proposals that had been launched on 15 March 2021 comprising two pillars - Digital Automated Coupler innovation for the European DAC Delivery Programme and R&I impact and benefits to make rail attractive for stakeholders. The Executive Director updated SRG on call for expression of interest for experts for ad hoc assignments to support the Shift2Rail Joint Undertaking. The SRG was also informed about a series of events foreseen in 2021.

The SRG was presented with a draft AAR 2020, with focus on visible achievements and pivotal milestones. The SRG representatives were invited to deliver their comments to the AAR 2020 in writing.

The sixteenth meeting of SRG took place in July 2021. The SRG was informed about the conclusion of the JU call for proposals 2021 and the awarded projects. The Executive Director informed the SRG about the opportunities for rail sector in the Horizon Europe programme. The members of the SRG discussed in detail the preparatory work for launching the Europe's Rail Joint Undertaking.

During the seventeenth meeting in October 2021, the SRG continued discussion on the preparatory work for launching Europe's Rail Joint Undertaking. The Executive Director overviewed a draft version of the Master Plan of the Europe's Rail Joint Undertaking, a key strategic document for the future programme of the JU. The SRG was invited to deliver comments on the Master Plan by 26 October 2021.

In all meetings, participants were informed in detail about the ongoing and planned activities of the JU, including progress in delivering the programme. They were updated on the European DAC delivery programme, the conclusion of memoranda of understanding with external parties, and the communication activities. The Executive Director provided a regular update on the preparatory work for the launch of the Europe's Rail Joint Undertaking and the negotiation over the Single Basic Act. The SRG was also regularly informed about the railway R&I activities in other Member States.

With entry into force of the Single Basic Act, the Commission launched in December 2021 a request to the Member States and associated countries to nominate their representatives to the EU-Rail States' Representative Group. To date, 27 countries have nominated their representatives to the SRG. No EU-Rail SRG meeting was held in 2021.

3.4. Scientific Committee (SC)

The SC is an advisory body to the JU focusing on the long-term research and on identifying scientific and technological achievements and development priorities.

In 2021 the Scientific Committee convened four meetings and one extraordinary meeting on ERTMS.

The fifteenth meeting of the Scientific Committee in February 2021 was dedicated to the discussion on the JU's successor. The Members of the Scientific Committee were informed about the status of the Single Basic Act negotiations, and the setup of the future Europe's Rail Joint Undertaking. The Members of the Scientific Committee were invited to express their opinion on the scientific advice under the Europe's Rail Joint Undertaking. The Scientific Committee also agreed to set up a task force on ERTMS and to organize a specific meeting to discuss the item. A special meeting was organized in July 2021 to discuss the report of the ERTMS task force.

During the sixteenth meeting in April 2021, the members of the Scientific Committee further discussed the setup of the Europe's Rail Joint Undertaking and the ongoing JU activities. The Experts were asked to provide their comments to the AAR 2020. The Shift2Rail Joint Undertaking also informed the Scientific Committee about the recommendations for programme level KPI assessment. The Members of the Scientific Committee were asked to provide their contribution to the paper "Action for the CCA work-area on KPI: paper on lessons learned and recommendations for the future", produced by the KPI team.

The seventeenth meeting of the Scientific Committee took place in October 2021. The Members of the Scientific Committee discussed their ideas to enhance the scientific advice under the Europe's Rail Joint Undertaking programme. The Experts were presented with the Master Plan of the Europe's Rail Joint Undertaking and asked for their opinions and comments.

The eighteenth meeting in November 2021 was the last meeting of the Scientific Committee under the JU programme. The Experts were informed about the transition process from Shift2Rail to the Europe's Rail Joint Undertaking, including the process of adoption of key documents and proposal of continuation of the current Scientific Committee under EU-Rail as an interim solution.

In October 2021 the Scientific Committee was consulted on the draft version of the Europe's Rail Joint Undertaking Master Plan in a written procedure.

The JU GB decisions on the selection of the Scientific Committee members (GB - 03/2015, GB -15/2016, GB-10/2017, and GB-06/2019) have been readopted by the EU-Rail Governing Board by means of the "Omnibus decision".

3.5. Innovation Programme's Steering Committees (SteCos)

The JU Programme Office convened regular IPs and CCA SteCos meetings (four per each IP/CCA in 2021, in total 24 meetings) accordingly to the IPs/CCA Rules of Procedure. The aim of these meetings was to ensure the necessary coordination of activities within each IP/CCA and to provide input in assisting the JU in the monitoring of the Programme activities, notably ensuring the Demonstrations activities planning and coordinated dissemination and communication activities. The coordinators of the CFM and OC projects were invited to participate to the SteCo meetings in order to present the progress of their works in a way to ensure coordination of actions and to maximise synergies among projects.

3.6. European Union Agency for Railways (ERA)

Both the S2R Statutes, and as of 30 November 2021 the SBA for EU-Rail, provide for a collaboration between the JU and ERA. In this respect, the rules of procedures of all relevant groups/bodies established under the JU foresee the participation of representatives from ERA (either as observers or their direct members). This ensures that the Agency is duly prepared to take into account the results of the Programme in its activities.

As a result, staff members of ERA have been participating in meetings of the JU's GB, SRG, Scientific Committee, and the IP/CCA SteCos. Due to participation in the work of these bodies, the representatives of ERA had access and contributed to the draft documents in preparatory work for establishment of the Europe's Rail Joint Undertaking.

The JU's Governance and Process Handbook⁴¹ clarifies the way ERA can access the R&I activities performed within the S2R Programme in the areas of their competence, interoperability and safety.

It is worth mentioning that the JU provided to ERA in 2018 the ATO over ETCS GoA2 specification and in 2019 the Moving Block (MB) system specification, MB operational and engineering rules as well as the MB preliminary safety analysis, all as input of the possible game changers integration in the next

⁴¹ https://shift2rail.org/wp-content/uploads/2021/03/S2RJU-Governance-and-Process-Handbook_20200303_v2.0.pdf

release of the CCS TSI. The work on the preparation of the update of the ERTMS/ETCS specifications for the TSI 2022 update was still ongoing, in full swing, in 2021.

The tender launched and awarded by the Joint Undertaking in 2017, following an ERA request to close a TSI open point, on “Pantograph – Overhead Contact Line Interaction – Dynamic Behaviour and Quality of the Current Collection” concluded its technical activities and ERA could accede to all results, formally provided to the Agency at the administrative closure at the beginning of 2021.

Through the S2R Framework Contract to support the ERTMS Deployment action, the JU had issued service contracts formulated with ERA and the European Commission for the maintenance of the ERTMS specifications as well addressing the technical updates for integration of the game changers into the regulation by the ERTMS system authority.

In addition, regular coordination meetings have been organised between the two EDs, operational staff and communication staff. The overall objective is to ensure that the R&I innovative solutions that will be delivered by the S2R Programme will be considered in the pipeline of ERA activities in order to avoid any step back in the future market uptake.

The role of ERA in the context of 4th Railway Package, is another asset to facilitate the deployment of the S2R Innovative Solutions.

In addition, with the objective to avoid overlapping activities, EU-Rail assesses the requests for R&I coming from ERA and ensure their implementation to maximize the use of public funding. Building upon parallel structures would constitute a waste of resources.

EU-Rail also supported the EC in its ERTMS Deployment Action Plan, participating to the ERTMS Policy Board meetings and advertising the ERTMS Deployment Action Plan Consultation on its website.

The JU participates together with ERA to the Rail Standardisation Coordination Platform for Europe (RASCOP) chaired by the European Commission (DG Move). In 2021, via the ad hoc working group on the Commission Standardisation request, EU-Rail provided its input in consultation with ERA and with the relevant European standardisation organisations. The JU identified the specific areas and activities which can provide input to harmonised standards to be reviewed in the next 5 years.

In 2021, the JU and ERA agreed on the Guidelines for R&D activities leading to technical standards, pending ERA confirmation on their finalisation. The Guidelines describe the measures supporting that research outcome and innovative solutions can quickly be used.

On the coordination on standardisation and regulation issues, the JU has been also participating in the EU Rail Security Platform providing expertise (also to ERA) based on the R&I outcomes on cybersecurity applied to ERTMS.

EU-Rail has also ensured along the year the contribution of its projects to ERA Topical Working Groups in view of the revision of the TSIs 2022 Package; such important work is paramount to accelerate the market uptake of the innovative solutions.

4. INTERNAL CONTROL FRAMEWORK

4.1. Financial Procedures

The current JU Financial Rules were adopted on 20 December 2019 by its Governing Board (Decision N°11/2019) and entered into force on 1 January 2020. By means of these amended Financial Rules, the framework for the JU's financial procedures reflected the applicable version of the General EU Financial Regulation 2018/1046 which entered into force on 18 July 2018. As per this legal framework, the JU's financial procedures are designed in a manner allowing compliance with the principle of sound financial management.

As it was under the JU, with EU-Rail becoming operational as of 30 November 2021, the JU continued to comply with the provisions of the applicable Model Financial Regulation. Any future departure from this Model Financial Regulation, as potentially required for the purpose of the Joint Undertaking's specific needs, shall be subject to the Commission's prior consent.

With regard to ICT tools applied to support its financial procedures, since 2016, the JU has utilized ABAC Workflow (accounting system of the European Commission). During the past years, the processes have been further reinforced with the introduction of the JU Cooperation Tool (including for in-kind contribution declarations and certifications) and the implementation of ICT tool ABAC Assets.

At the time of deployment of ABAC Workflow as mentioned above, the JU adopted its Manual of Financial Procedures including the applicable Financial Circuits. This Manual of Financial Procedures was further revised in a new version in 2017 and amended again later in 2019. It has been designed to guarantee a segregation of duties and to apply the four eyes principle in JU's financial transactions. In this respect, the initiation of a financial transaction and its verification are performed by different actors (ABAC users). Furthermore, the document describes in detail the financial circuits the JU implements per type of transactions and the roles and responsibilities of each actor involved in the implementation of its budget. To a lesser extent, it also describes the basic principles of main procedures (grants & procurements).

In the view of adapting to the new framework and the new Programme to be managed by the Europe's Rail Joint Undertaking, the JU has initiated the revision of the main documents relating to its activities. This process will continue in 2022.

As for the JU budget it comprises in principle two main types of expenditure:

- Administrative Expenditure covering both Titles 1 and 2 of the Budget, and
- Operational Expenditure covering Title 3 of the Budget.

The Title 4 is dedicated to account for unused appropriations.

Due to their nature and the difference in ICT tools implemented at the JU to manage them, the financial circuits for these two expenditure types are different.

It should be noted that in addition to the JU-specific methodological framework for financial procedures, overall rules established for the Horizon 2020 research family (*Vademecum*) are applied as well.

In 2021, for accounting purposes, the JU continued to utilize the services of the Accounting Officer of the Commission based on the respective decision of S2R Governing Board adopted in 2016. However, in October 2021 DG BUDG announced the intention to terminate their role of the Accounting Officer

of the JU, later confirmed to be effective as of 1 December 2022, except for the treasury function. This decision was linked to the foreseen establishment of the back-office arrangements between the JUs in accordance with the SBA. This situation represents a risk of jeopardising of the JU's reporting cycle and its legal obligations, as replacing the EC Accounting Officer by the back-office arrangements may not be without difficulties, especially with regard to the fact that the necessary skills and competence are scarce and limited within the EU-Rail, as well as overall in all JUs. EU-Rail will seek in 2022 with the other JUs how to deal with this challenging situation.

4.2. Ex-ante Controls on operational Expenditure

In 2021, the JU continued to follow the procedures for ex-ante controls defined internally (JU Financial Rules) as well as the common Horizon 2020 ex-ante control framework.

EU-Rail has followed the Article 21(1) of its Financial Rules providing that "each operation shall be subject at least to an ex-ante control relating to the operational and financial aspects of the operation, on the basis of a multiannual control strategy which takes risk into account". The ex-ante controls are considered essential to prevent errors and to avoid the need for ex-post corrective actions. They take the form of checking contracts and grant agreements, initiating, checking and verifying invoices and cost claims and carrying out desk reviews (such as mid-term reviews carried out by external experts on JU's projects and other).

The JU applied standard financial circuits in ABAC Workflow for the commitments and payments. The circuit has a three-step authorisation performed by the following financial actors:

- Initiating Agent (OIA and FIA)
- Verifying Agent (OVA and FVA) and
- Authorising Officer (AO).

Staff members designated by the AO to verify financial operations are chosen on the grounds of their knowledge, skills, and appropriate professional experience.

The JU financial circuits comply with the requirements of the four eyes principle, segregation of duties and the independence of the verifier. At the same time, they allow also for the necessary flexibility to ensure the continuity of operations, with regard to limitations in the number of staff.

For the operational expenditure, the JU recognises two different types of transactions: the ones solely performed in the ABAC Workflow and the ones with the initiation and verification functions outside of the ABAC environment - in the SyGMa tool. This tool is also linked to ABAC which allows real time controls over the budget and its implementation.

The particular system where the initiation and verification are to be performed is derived from the nature of the transaction, as follows:

- ABAC for all procurement related transactions, and
- SyGMa for any transactions related to grant management.

However, in all transactions, irrespective of whether initiated in SyGMa or ABAC, the AO will always give his/her authorisation in ABAC only.

A key element of the ex-ante controls is the “*Guidance Horizon 2020 ex-ante controls on interim & final payments*” adopted by the CSC Steering Board on 15 Dec 2016 and applicable as such to the JU. As a consequence of the approach introduced in this guidance, simplified ex-ante controls are applied. In particular, the level of details asked from the beneficiaries to be provided in each periodic report is limited, allowing the JU to check a limited number of conditions regarding the eligibility of costs. Ex-ante controls in Horizon 2020 are therefore trust-based, focusing on whether:

- the work has been done (as described in the periodic reports),
- the reported effort and use of resources are reasonable and in accordance with the plan,
- sufficient explanation and justification are provided for any substantial deviations.

In practice, the assessment involves comparing the Description of the Action (DoA) and the budget earmarked with the work actually carried out, as per explanation provided in the periodic report, and with the costs being claimed by the beneficiaries in connection with it.

Certain elements (such as risk factors or deviations) are scrutinized to a lower extent when checking interim periodic reports when compared to assessing final reports. Moreover, since CFS are required only as part of the final reports, ex-ante controls in final periods are more in-depth. In addition, officers may take a more flexible approach to ex-ante controls in interim periods by asking beneficiaries for additional clarification in the ensuing reporting period. However, by the time the final payment is made, all outstanding issues should have been dealt with.

4.3. Ex-post Control of Operational Expenditure and Error Rates Identified

Ex-post controls are defined as the controls executed to verify the financial and operational aspects of finalised budgetary transactions in accordance with Article 22 of the JU Financial Rules. The main objectives of the ex-post controls are to ensure that the principles of legality, regularity, and sound financial management (economy, efficiency and effectiveness) have been respected and to provide the basis for corrective and recovery activities, if necessary.

The controls are the last stage of the JU’s control strategy in the project life cycle. This stage includes the ex-post audits as well as the recovery/correction of any amounts found to have been paid in excess of the sum eligible.

Ex-post Control of Operational Expenditure at EU-Rail is covered by the Horizon 2020 Audit Strategy. The implementation of the Horizon 2020 Audit Strategy falls under the responsibility of the Common Audit Service (CAS) of the Commission. The role of the CAS is defined in the Commission Decision “C(2014) 2656 final” on the operating rules for the Common Support Centre for Horizon 2020, the Framework Programme for Research and Innovation (2014-2020)⁴². As follows from this Decision “*The Common audit service shall contribute to assessing the legality and regularity of Horizon 2020 project payments by means of ex-post financial controls carried out, either by its own auditors or by independent audit firms in accordance with the decisions of the Steering Board. It shall provide the relevant Authorising Officers by Delegation (AODs) with necessary elements of assurance on the research budget for which they are responsible.*”

The main actions identified to realise the objectives following from the Horizon 2020 Audit Strategy include:

⁴² [https://ec.europa.eu/transparency/documents-register/detail?ref=C\(2014\)2656&lang=en](https://ec.europa.eu/transparency/documents-register/detail?ref=C(2014)2656&lang=en)

- the gradual achievement, in a cost-effective way, of quantitative multi-annual targets in terms of audited participations⁴³;
- the closure and communication of audit findings and extension of audit findings to those responsible for their implementation providing the basis for corrective and recovery activities, if necessary.

For Horizon 2020, the CAS carries out all audits, including those concerning grants concluded by the Executive Agencies and the Joint Undertakings. This is a major step towards ensuring a harmonised approach, legal certainty, equality of treatment and minimising the audit burden on beneficiaries.

The main indicators on legality and regularity of EU Framework Programmes for Research and Innovation are:

- **Representative detected error rate**, based on errors detected by ex-post audits on a Common Representative Sample of cost claims across the R&I Family.
- **Cumulative residual error rate**, which is the extrapolated level of error after corrective measures have been implemented by the Commission services following the audits, accumulated on a multi-annual basis.

The target set for Horizon 2020 is to ensure that the cumulative residual error rate remains within a range of 2-5 % aiming to be as close as possible to 2%.

Progress against Horizon 2020 targets is assessed annually based on the results of the implementation of the ex-post audit strategy and taking into account the frequency and importance of the detected errors along with cost-benefit considerations regarding the effort and resources needed to detect and correct the errors.

It should be noted, however, that due to its multi-annual nature, the effectiveness of the control strategy of the R&I Family can only be measured and assessed fully in the final stages of the EU Framework Programme, once the ex-post control strategy has been fully implemented, and errors, including those of a systematic nature, have been detected and corrected.

The target set for Horizon Europe will be to ensure that the cumulative residual error rate does not exceed 2%⁴⁴.

Ex-post controls of the Horizon 2020 programme globally in 2021

In 2020, the Commission refined its methodology for calculating the Horizon 2020 error rates in line with the European Court of Auditors' observations in its 2018 and 2019 Annual Reports⁴⁵. As of January 2020, DG R&I applied the revised methodology on a sample of 1 304 audit conclusions. This resulted in the following error rates for Horizon 2020⁴⁶ as of 31 December 2021:

⁴³ A participation is the combination of a beneficiary and an action. An audit can cover more than one participation.

⁴⁴ No representative error rate for Horizon Europe will be available in 2022 and 2023 as the ex-post audit campaign for the Programme is planned to be launched by the end of 2023, at the earliest.

⁴⁵ When calculating the multi-annual error rate, the Commission took into account the results of the audit re-performed by the ECA as part of Module 2 of the DAS 2018-2019.

⁴⁶ The Horizon 2020 audit campaign started in 2016. At this stage, four Common Representative Samples with a total of 629 expected results have been selected. By the end of 2021, cost claims amounting to EUR 31.8 billion have been submitted by the beneficiaries to the services. In addition to the Common Representative Samples, Common Risk Samples and

- Representative detected error rate: 2,29%⁴⁷,
- Cumulative residual error rate for the Research and Innovation Family DGs: 1,60% (1,67 % for DG Research and Innovation⁴⁸).

These error rates are calculated on the basis of the audit results available when drafting the Annual Activity Report. They should be treated with caution as they may change subject to the availability of additional data from audit results.

Since Horizon 2020 is a multi-annual programme, the error rates, and the residual error rate in particular, should be considered within a time perspective. Specifically, the cleaning effect of audits will tend to increase the difference between the representative detected error rate and the cumulative residual error rate, with the latter finishing at a lower value.

The decrease of the error rates in year 2021 could be due, among other reasons, to the beneficiaries' increased knowledge of the eligibility rules and its inherent learning curve, as well as to the results of the communication campaigns, targeted webinars and trainings, addressed in particular to newcomers and SMEs.

Given the results of the audit campaign up until 2021, and the observations made by the European Court of Auditors in its Annual Reports, the Common Implementation Centre, in close cooperation with central Commission services, is defining actions aimed at significantly simplifying the rules, and paving the way for a significant reduction of the error rate in Horizon Europe. Actions were undertaken including further simplification, increased use of simplified forms of funding (including lump sums and unit costs), focused communication campaigns to more "error-prone" types of beneficiaries with higher-than-average error rates, such as SMEs and newcomers, and enhanced training to external audit firms performing audits on behalf of the Commission (the last three measures also target H2020 grants and beneficiaries). Focusing on the most common errors, these events will be straightforward, reaching more participants and achieving higher impact.

In the context of further reducing the error rates, the Common Implementation Centre will revisit the existing tools for ex-ante controls. It will consult the stakeholders in order to collect their views on possible improvements in the grant management risk module.

2021 was the first year of implementation of the Horizon Europe framework programme. The adoption of its Regulation later than initially planned, delayed the starting of its implementation⁴⁹. By the end of 2021, only a very limited number of payments was executed (only pre-financings in DG R&I). Consequently, taking into account the absence of relevant expenditure, the low-risk nature of the implemented transactions and the absence of ex-post audit results for grants, no detected error rate can be reported for Horizon Europe in 2021.

Additional Samples have also been selected. The audits of 3 424 participations were finalised by 31/12/2021 (of which 514 in 2021).

⁴⁷ Based on the 418 representative results out of the 629 expected in the four Common Representative Samples.

⁴⁸ It should be noted that in 2021 most H2020 grants managed by DG R&I were transferred to Executive Agencies. Hence, this figure is based only on the actions that remained with DG R&I at the end of 2021.

⁴⁹ At the end of 2021, for the R&I family, 64 calls for proposal had been fully evaluated and only 19 grant agreements had been signed (3 for DG R&I)

Ex-post control 2021: EU-Rail Specific sample

Given the relatively small share of the EU-Rail’s budget (less than 1%) compared to the overall H2020 budget, the number of projects selected for ex-post audit by the CAS via the common representative sample is limited. Therefore, EU-Rail in line with Annex 1 to the H2020 audit strategy planned for additional audit sampling (i.e. JU’s specific sample) in order to ensure sufficient ex-post audit coverage and allow a representative error rate on EU-Rail expenditure to be calculated over time. This is necessary to provide reasonable assurance to the JU’s Executive Director in view of his declaration of assurance and the separate discharge procedure for the JU. There were no EU-Rail cost claims selected by the CAS as part of the Common Representative Samples for the H2020 research family in years 2016 and 2017. In the third Common Representative Sample, two JU participations were selected. In addition, four risk- based audits on EU-Rail participations have been launched up to year end 2021 as part of the H2020 Audit Strategy implementation.

In 2017, in addition to the risk-based audits mentioned above, the JU launched representative audits covering 15 additional participations. After launching the representative audits, the total coverage raised into KEUR 1 324 representing 40% of all cost claims validated in that year. With the additional audits launched during 2019, the direct coverage of the EU-Rail launched audits into KEUR 7 404 (10%) and in-direct coverage into KEUR 39 96216 757 (52%).

By 31 December 2020, the JU validated cost claims for a cumulative total of EUR 115.126.105,19 covering 59 projects. In 2020, the JU selected 25 additional representative audits on its population as well as two risk-based audits following its own risk assessment. This brought the direct coverage of the EU-Rail audits into EUR 6.830.350 (6%) and in-direct coverage into EUR 68.466.576,68 (59%).

In July 2021 the CAS confirmed the selection of the EU-Rail participations/periods counting towards its 2022 local representative audit target. The selection includes 9 participations/10 periods.

As of 31 December 2021, total cumulative cost claims related to projects managed by EU-Rail, hence representing its auditable population, reached the amount of EUR 184.338.580,08 for 72 projects. As for the amount of cost claims actually audited by the end of 2021, it was EUR 12.327.178,29 representing the direct EU-Rail audit coverage of 6,7%. The in-direct coverage, i.e. the total directly non-audited cost claims of all audited EU-Rail beneficiaries amounted to EUR 121.831.436,24 (66%).

The overall status for H2020 ex-post audits related to the JU projects as of yearend 2021 is shown below⁵⁰.

Number of participations for which audits were launched during individual years (risk-based audits not included):

GROUP	Total Launch 2016	Total Launch 2017	Total Launch 2018	Total Launch 2019	Total Launch 2020	Total Launch 2021	Launch Total	Sched Total	Open Total	Sched + Open + Closed Total
EU-RAIL	0	16	17	12	39	13	97	0	19	97

Number of participations for which the audits ended (risk-based audits not included):

⁵⁰ As per the data files provided by the CAS.

H2020 - CAS - PARTICIPATIONS CLOSED PER CLIENT - OVERALL VIEW - TOP-UPS and ECA JOINT AUDITS INCLUDED

Framework	Domain	Client	Closed 2016	Closed 2017	Closed 2018	Closed 2019	Closed 2020	Closed 2021	Closed Total
H2020	CAS	EU-RAIL	0	0	4	22	22	30	78

Number of participations subject to top-ups/risk-based audits:

Entity	CRS3				CORP RISK				Counts Towards LOCAL RISK TARGET	LOCAL RISK 2021 SCHED	LOCAL RISK 2021 OPEN	LOCAL RISK 2021 CLOSED
	SCHED	OPEN	CLOSED		RISK 2020-03 SCHED	RISK 2020-03 OPEN	RISK 2020-03 CLOSED					
EU-RAIL	3	0	1	2	0	0	1	1	0	1	0	

Overview of cost claim figures related to the JU projects as of 31/12/2021:

Total number of validated cost claims	1988
Total cost accepted by JU (cumulative) (A)	184.338.580,08
Total cost audited by the end of 2021 (B)	12.327.178,29
Total not directly audited cost claimed by audited S2R beneficiaries (C)	121.831.436,24
Direct audit coverage ratio (B / A)	6,7%
In-direct audit coverage ratio (C / A)	66%

As of 31 December 2021, 66 final audit reports from ended ex-post audits covering the JU's projects were available.

Overall detected error rate based on 80 participations: by applying simple average is 2,69% and by applying weighted average is 2,21%.

Representative Error Rate based on 76 participations: by applying simple average is 2,74% and by applying weighted average 2,27%.

EU-Rail Residual Error Rate: by applying simple average is 1,35% and by applying weighted average is 1,33%.

As at the cut-off date 31.12.2021, **the JU's cumulative residual error rate is below the targeted threshold of 2%** under both methodologies - the simple and the weighted average.

4.4. Control efficiency and cost-effectiveness

This section provides information about the JU's costs of control and the cost-effectiveness of controls applied by EU-Rail⁵¹.

JU's resources dedicated to ex-ante controls in connection to grants:

Stage of the control	Description	Year			
		2020		2021	
		EUR	FTE	EUR	FTE

⁵¹ The information presented in this AAR Section corresponds with data reported to DG BUDG with respect to cost of control.

Stage 1 – Programming, evaluation and selection	Cost of programming + evaluating + selecting / value contracted	84.000	1	84.600	1
Stage 2 – Contracting including financial (commitments, guarantees,...) and legal checks	Cost of controls related to the contracting / amount paid	37.100	0,5	38.700	0,5
Stage 3 – Monitoring the execution and ex-ante financial management	Cost of controls related to the monitoring of the execution / amount paid	271.000	3,6	269.500	3,6
Total ex-ante		392.000	5,1	392.800	5,1

JU's resources dedicated to ex-post controls in connection to grants:

Stage of the control	Description	Year			
		2020		2021	
		EUR	FTE	EUR	FTE
Stage 4 – Ex-post controls and recoveries	Total cost related to ex-post audits / grants audited	30.900	0,4	33.200	0,4
Total ex-post		30.900	0,4	33.200	0,4

The cost of ex-ante controls related to grants are then representing 1% of the EU-Rail operational expenditure in 2021 and 0,9% of the total JU's expenditure.

JU expenditure in 2021 in EUR millions		Estimated costs of ex-ante controls in 2021 in EUR	Costs of ex-ante controls in relation to expenditures in %
Operational	39,5	392.800	1.0%
Total	42,9		0.9%

In terms of own human resources allocated in 2021 to controls related to grants, both ex-ante and ex-post, approximately 5,5 FTEs were involved. This represents about 24% of the total FTEs employed by the JU as at year end 2021.

The total estimated costs of control (ex-ante + ex-post) for grant management⁵² in 2021 represents the amount of EUR 426.000 which is similar to 2020, and thus indicating a stabilized situation with regard to deployment of JU's resources to these control activities. However, this might change in the years to come with the implementation of the Horizon Europe Programme, for example due to application of lump sum grants. As a result, not only the total amount of JU's costs of control could change, but also the ratio between costs related to ex-ante and ex-post controls applied by the Joint Undertaking.

The following table presents indicators for cost-effectiveness based on total costs of Grants control in 2021:

Cost of controls / Total expenditure 2021 (administrative + operational)	1,0%
Cost of controls / Operational expenditure 2021	1,1%

The ratios provided above can be used as one of the sources of information to assess the overall cost-

⁵² Costs related to own human resources dedicated in 2021 to control activities connected to grants.

effectiveness of the control strategy applied by EU-Rail for the grants it manages. However, they have to be combined with considerations of other elements which are not quantifiable. In addition, especially in terms of comparing to other granting authorities, specificities of EU-Rail have to be taken into account. For example, the size of the JU in terms of number of staff represents an objective limitation for the JU's ability to achieve economies of scale when performing control activities.

In conclusion, from the JU's perspective, controls applied in grant management are considered cost-effective, respecting the efforts to simplify and minimise the administrative burden for beneficiaries on one hand, and providing reasonable assurance as regards the sound financial management of the grant implementation on the other hand.

4.5. Audit of the European Court of Auditors

The European Court of Auditors (ECA) with its mission of March 2021 completed its work which resulted in the JU's Annual Audit Report for the year 2020, in accordance with the ECA mandate as defined in the TFEU.

During 2021, for the 2020 Financial Year, the European Court of Auditors released the following opinions:

Opinion on the reliability of the accounts

"In our opinion, the accounts of the JU for the year ended 31 December 2020 present fairly, in all material respects, the financial position of the JU at 31 December 2020, the results of its operations, its cash flows, and the changes in net assets for the year then ended, in accordance with its Financial Regulation and with accounting rules adopted by the Commission's accounting officer. These are based on internationally accepted accounting standards for the public sector."

Opinion on the legality and regularity of revenue underlying the accounts

"In our opinion, revenue underlying the accounts for the year ended 31 December 2020 is legal and regular in all material respects."

Opinion on the legality and regularity of payments underlying the accounts

"In our opinion, payments underlying the accounts for the year ended 31 December 2020 are legal and regular in all material respects."

For the year 2020, the ECA reported no major or critical findings for the JU in its Annual report on EU Joint Undertakings for the financial year 2020. However, two observations were raised:

- That only a few of the GB members duly submitted their up-to-date CVs and conflict of interest declarations (none of the conflict of interest declarations and only half of the CVs could be published by the end of 2020).
- As part of the operational payment controls, the ECA audited randomly sampled Horizon 2020 payments made in 2020 at the level of the final beneficiaries to corroborate the ex-post audit error rates. These detailed audits revealed in one case, a systemic error because of the use of a wrong method for the calculation of declared personnel costs. In another case, a systemic non-quantifiable control weakness was detected related to the absence of the beneficiary's validation procedure for the hours declared as spent working on the project.

On the first observation, the necessary actions have already been taken with the establishment of the new GB for EU-Rail. The CVs as well as annual declarations of interests of the GB members are publicly available in the JU official website.

On the second observation, the finding in respect of the absence of the beneficiary's validation procedure for hours declared was covered in an ex-post audit performed by the CAS end of 2020 reporting no required financial adjustments. This report concluded that in general, the time recording system of the beneficiary is reliable. In addition, the beneficiary has confirmed that improvement in the time recording validation system will be implemented, and that follow-up information will be sent to the JU.

Furthermore, it is confirmed that the corrective actions taken by the JU in response to the Court's observations from previous years were mostly completed, while in one case the action is ongoing. In particular, it concerns one observation from 2017: In response to the recommendations raised by the evaluators, the Joint Undertaking prepared an Action Plan adopted by the Governing Board on 28 June 2018. While not all recommendations raised in the Interim Evaluation had been addressed under the former Financial Framework Programme, some actions included in the Action Plan have already been initiated, while others, in accordance with their nature and the new legal framework, are expected to be implemented in the period 2018 to 2020. The final ECA report on FY 2020 was published at Q4 2021 and includes a consolidated view of the audit and finding for all the Joint Undertakings. Chapter 3 of the report regroups the individual Statements of Assurance for each JU; section 3.8 being the one specific to EU-Rail.

In addition, following the draft preliminary ECA observations on fiscal year 2021, three findings were raised and still under discussion, regarding:

- the Pension scheme of the JU, for which ECA's interpretation is that the S2R Members other than the Union shall contribute to 50% with EC. DG BUDG has formally confirmed that even though it could be interpreted that the Members other than the Union should contribute to the pension scheme, it is not within the proportion 50/50, but rather in proportion to their general contribution to the JU's administrative costs vs. the entire S2R Programme contribution. Which would then make such contribution immaterial (3%). Finally, DG BUDG also considers that it should be applicable only from the new programming period HE.
- Late interest not requested for delayed recoveries on administrative contribution from the Members other than the Union. The EU-Rail's interpretation to this is that the issue could also be considered as not relevant due to low materiality.
- Lack of definition of "administrative costs", to which the JUs disagree, as this is clearly established in the Financial Statements accompanying the setting up of the JUs and the SBA.

Considering that EU-Rail has sent its formal replies before yearend 2021, the discussion on the topics should be considered still ongoing and the results subject to further confirmation.

4.6. Internal Audit

In accordance with Article 28 of the JU Financial Rules, the internal audit function shall be performed by the Commission's Internal Audit Service (IAS). IAS reports on its findings and recommendations to the Joint Undertaking's GB and ED.

The internal auditor shall advise the JU on dealing with risks, by issuing independent opinions on the quality of management and control systems, and by issuing recommendations for improving the implementation of operations and promoting sound financial management.

In line with the International Standards for the Professional Practice of Internal Auditing IAS confirmed in January 2022 to the Chairperson of the EU-Rail GB and to the ED its organisational independence of their internal audit activity conducted in 2021, as well the fact that their work in 2021 was free from interference in determining the scope of internal auditing, performing work and communicating results. IAS also confirmed that in 2021, there was no impairment to individual objectivity, in particular through conflict of interest, scope limitations, restrictions on access to records, personnel, and properties, or resource limitations.

Following its risk assessment performed at the JU during 2020, the Internal Auditor drew up the Strategic Internal Audit Plan for 2021-2023. In Q4 2021 the JU provided IAS with an update on the internal and external developments having influence on its business, as well as with its updated version of the risk register. IAS will take this input into account for the preparation of its planning of the audit work for 2022 and for the establishment of the next in-depth risk-assessment and strategic internal audit plan of EU-Rail.

In 2021, IAS launched an “Audit on H2020 grant implementation and closing”. The objective of this audit is to assess the adequacy of the design and the efficiency and effectiveness of the internal controls in place in the JU for the implementation and closing of grant agreements under H2020.

At the time of drafting of this AAR, the findings and recommendations from this audit were not yet available, the audit is expected to be finalized in the first half of 2022. EU-Rail will take into account the audit results in the design of its control framework and control practices by means of an adequate action plan.

As for the follow up on the findings from the previous IAS audit on grant process from the identification of the call topics to the signature of the grant agreement, all four recommendations were implemented⁵³.

4.7. Risk management and conflict of interest

The Joint Undertaking has an established Risk Management that has been implemented within the JU for the last 5 years. It follows the principles of the recognised international standards and aligns to the requirements of the Commission as indicated in its Communication SEC(2005)1327 *“Towards an effective and coherent risk management in the Commission services”*⁵⁴. It is a continuous process involving clear communication to governance bodies, staff, and stakeholders on how EU-Rail positions itself in the management of risks and opportunities that can affect the achievement of its objectives, taking into consideration the assessment of the level of uncertainty that the JU is willing to accept (risk appetite). The Executive Director approves the policy and sets the tone, staff at the different levels implement the policy in the day-to-day operations. The Governing Board endorses the JU’s risk register brought to its attention by means of the Annual Activity Report.

Risk is defined as *“any event that could occur and adversely impact the achievement of the Joint Undertaking’s strategic and operational objectives. Lost opportunities are also considered a risk”*.

⁵³ The last outstanding recommendation related to the call development procedure was closed in January 2021.

⁵⁴ https://ec.europa.eu/info/sites/default/files/about_the_european_commission/eu_budget/sec-2005-1327_2005_en.pdf

The Risk Management system aims at enabling informed decision making with the objective of optimising the ratio between the level of risk acceptable to the JU on one hand, and, on the other hand, the use of the relevant resources related to identifying, analysing, treating, and monitoring of risks and opportunities.

In the months of September and October 2021, in accordance with the JU's Policy for Risk Management as defined in its Governance and Process Handbook, the JU performed a risk assessment exercise with the aim of updating the elements related to risks and opportunities already included in its risk register, as well as identifying potential new ones. Within this exercise, the specificities of the transition period from S2R JU to EU-Rail were also duly taken into account, similarly to other topical internal and external factors and developments having influence on JU's business. Due attention was given also to the fraud risks. The relevant risks following from this assessment exercise which require, due to their criticality, continuous attention and treatment of the Executive Director and, where relevant, of the Governing Board, are presented in the JU Work Programme 2022-2024 and the follow-up outcomes on these risks will be presented in the 2022 AAR.

It is foreseen to launch an in-depth risk assessment in the Q4 2022, to identify both operational and non-operational (corporate) risks that may affect the achievement of the JU's objectives.

As for the treatment of potential conflicts of interests, and to implement the requirements following from its constituent act with regard to this matter, the JU has adopted the respective rules by means of its internal legal framework in relation to its Members, staff, as well as the members of its Governing Board. The annual declarations of interests of the latter are publicly available in the JU official website.

Thus, as it was the case in the past, EU-Rail will continue also in the future to apply various measures, such as:

- requiring annual declarations of interests from the staff members;
- utilization of independent experts in selection procedures who will be obliged to declare any potentially conflicting interests;
- requiring annual declaration of interests from the Governing Board members, as well as declaration of confidentiality and conflict of interest from all attendees to each EU-Rail's Governing Board meeting.

Furthermore, the JU Executive Director will continue in the practice of stressing to the staff and to the GB members the importance of compliance to the highest standards in ethical matters, including the situations potentially involving conflicts of interests.

4.8. Anti-Fraud Implementation and Indicators

During 2021, the JU continued to implement its Anti-Fraud Strategy that was established in 2017⁵⁵. It is based on three main objectives, in particular:

- to maintain a culture of integrity among staff and to build capacities through training and guidance;
- to ensure a high level of reactivity in case a fraud case is suspected, with the involvement of OLAF;

⁵⁵ <https://shift2rail.org/wp-content/uploads/2022/01/Anti-Fraud-Strategy-extended-until-30.06.2022.pdf>

- to prevent leakage of sensitive/confidential information, and thus, to prevent misuse of such unauthorised access to that information.

Integral part of this Anti-Fraud Strategy is the related action plan covering, to a reasonably applicable extent, all stages of the anti-fraud cycle: prevention, detection, investigation and corrective measures. The action plan, subject to regular bi-annual reviews, is also a means for ongoing inclusion of new anti-fraud actions and measures, and for amending the existing ones, as deemed necessary to accommodate changes in the JU's fraud risk situation, as well as amendments in the higher-level anti-fraud policies. These policies include the current European Commission Common Anti-Fraud Strategy, the Common Anti-Fraud Strategy in the Research Family, and the Anti-Fraud Strategy with the related Action Plan of DG MOVE, being the parent DG for EU-Rail. When implementing the actions, the JU takes advantage from sharing knowledge and experience by participating in the Fraud and Irregularities in Research (FAIR) Committee and its substructures. In addition, EU-Rail also makes as much as possible use of cooperation with other Joint Undertakings.

Given the specificities related to the transition from the S2R JU to EU-Rail, the current Anti-Fraud Strategy was extended until 30 June 2022. In 2022, a new EU-Rail Anti-Fraud Strategy is foreseen to be drafted and adopted, taking also on board the newest available elements and requirements provided in the relevant anti-fraud-related documents of the Commission, Research Family and DG MOVE, and also following up on the developments related to the common back office arrangements among the JUs, as foreseen by Article 13 of the SBA.

In accordance with the JU Anti-Fraud Strategy, and in line with agreement on usage of common indicators within the Research Family, the below indicators with regard to the results of fraud prevention and detection activities are reported as at year end 2021:

	Indicator	Result
1	Number and value of contracts subject to close monitoring or additional controls due to an assessment of a high risk of fraud.	0
2	New cases sent to OLAF and opened in the year, and cases handled by OLAF relevant to EU-Rail in 2021.	0
3	Number of OLAF financial/administrative recommendations received in 2021.	0
4	Time elapsed between receipt by staff or management of first information on alleged internal fraud and transmission to OLAF.	NA
5	Time elapsed between OLAF requests for information and date when information is provided to OLAF.	NA
6	Time elapsed between receipt of an OLAF report and the decision on recovery or disciplinary sanctions by EU-Rail.	NA
7	Awareness-raising actions performed.	<ul style="list-style-type: none"> • In the staff meeting of 12 November 2021, the JU Internal Control Coordinator held a presentation on ethics and anti-fraud. • A reference sheet was created and made available to all staff containing

	Indicator	Result
		information and links to various documents and data sources covering areas such as general information on fraud, fraud indicators (red flags), ethics and integrity, whistleblowing, and potential penalties/measures in case of misconduct, irregularities, and fraud.
8	Cooperation with relevant stakeholders in anti-fraud activities.	EU-Rail representative participated in the FAIR Committee. In 2021, three FAIR Committee meetings were held.

4.9. Compliance and effectiveness of Internal Control

In 2019, the JU started the process of implementing its new Internal Control Framework (ICF) based on the EC Internal Control Standards, also with the objective of introducing a more pro-active approach in the design and implementation of internal controls, rather than focusing mostly on the compliance aspects. This process resulted in 2020 in the adoption of a revised ICF by means of the Executive Director's Decision ED-20-08.

The JU's ICF is designed to provide reasonable assurance regarding the achievement of the following objectives:

- Effectiveness, efficiency and economy of operations;
- Reliability of reporting;
- Safeguarding of assets and information;
- Prevention, detection, correction and follow-up of fraud and irregularities;
- Adequate management of the risks relating to the legality and regularity of the underlying transactions, taking into account the multiannual character of programmes as well as the nature of the payments concerned.

Ever since the revised ICF was adopted, it has been implemented by the Executive Director in the organisation's day-to-day activities, with the support of the Internal Control Coordinator, involving all staff across all JU functions as well. This process included also further fine-tuning of the internal controls and maintaining awareness among the staff of the ICF and its importance for achieving the JU's objectives.

A first annual self-assessment of the JU's revised ICF was performed in Q1 2021 in order to evaluate the compliance and effectiveness of internal controls, looking back to 2020, as well as reflecting the current situation in internal control activities existing at that time. The results following from this assessment were presented in 2020 AAR.

Similarly, a new annual ICF assessment evaluating the situation in 2021 was conducted in Q1 2022 both at the level of its individual 17 Principles, 5 Components, and from the perspective of the framework as a whole. This assessment was carried out on the basis of 53 indicators and taking into account all relevant information available at that time, including the results from previous internal/external audits and the records in the JU's register of exceptions and non-compliance events.

After due assessment, no relevant deficiencies in internal controls were identified. All individual ICF Principles as well as Components were found to be present and functioning well. Thus, on this basis, it can also be concluded that the overall JU's control system is working properly and efficiently.

5. MANAGEMENT ASSURANCE

5.1. Assessment of the Annual Activity Report by the Governing Board

The ED submits the draft AAR to the Joint Undertaking's Governing Board for assessment and approval. Once approved by the GB, the AAR is made publicly available. No later than 1 July of each year the AAR together with its assessment shall be sent by the Executive Director to the European Court of Auditors, to the Commission, to the European Parliament and to the Council.

The EU-Rail GB takes note of the results achieved and recommends the JU to continue improving its effectiveness and efficiency with the Members' stronger support.

5.2. Elements supporting assurance

In addition to the specific supervisory activities of the ED, the main elements supporting the assurance are:

- the Certificate of the Accounting officer,
- the information received from the Head of R&I, the Head of Administration and Finance, the Data Protection Officer,
- the assessment of the Internal Control Framework carried out by the JU's Internal Control Coordinator,
- the results of the audit of the ECA,
- audits performed by the Internal Audit Service,
- the overall risk management performed in 2021 as supervised by the ED,
- the key performance indicators in place,
- the dedicated ex-ante controls of the JU's operational and administrative expenditure,
- the results from ex-post audits carried out by the Commission services,
- the S2R Other Members' reporting of in-kind contributions,
- the follow-up and monitoring of Call process,
- information reported in the JU's register of exceptions and non-compliance events and the related remedial measures put in place.

5.3. Reservations

The ED is not aware of any element that would bring him to introduce a reservation in the AAR 2021.

5.4. Overall conclusion

Not applicable.

6. DECLARATION OF ASSURANCE

I, the undersigned, Carlo M Borghini, Executive Director of the Europe's Rail Joint Undertaking

In my capacity as authorising officer by delegation

Declare that the information contained in this report gives a true and fair view⁵⁶.

State that I have reasonable assurance that the resources assigned to the activities described in this report have been used for their intended purpose and in accordance with the principles of sound financial management, and that the control procedures put in place give the necessary guarantees concerning the legality and regularity of the underlying transactions.

This reasonable assurance is based on my own judgement and on the information at my disposal, such as the results of the self-assessment, ex-post controls, the work of the Internal Control Coordinator, the observations of the Internal Audit Service and the lessons learnt from the reports of the Court of Auditors for years prior to the year of this declaration.

Confirm that I am not aware of anything not reported here which could harm the interests of the Joint Undertaking.

Brussels, 24 June 2022

Carlo M Borghini,
Executive Director

⁵⁶ True and fair in this context means a reliable, complete, and correct view on the state of affairs in the Joint Undertaking.

7. ANNEXES⁵⁷

⁵⁷ It should be noted that the Annexes related to publications from Projects, patents from Projects, materiality criteria are not included considering that the Projects' activities started only 1 September 2016.

ANNEX A Organisational structure of EU-Rail

Organisational structure applicable in 2021

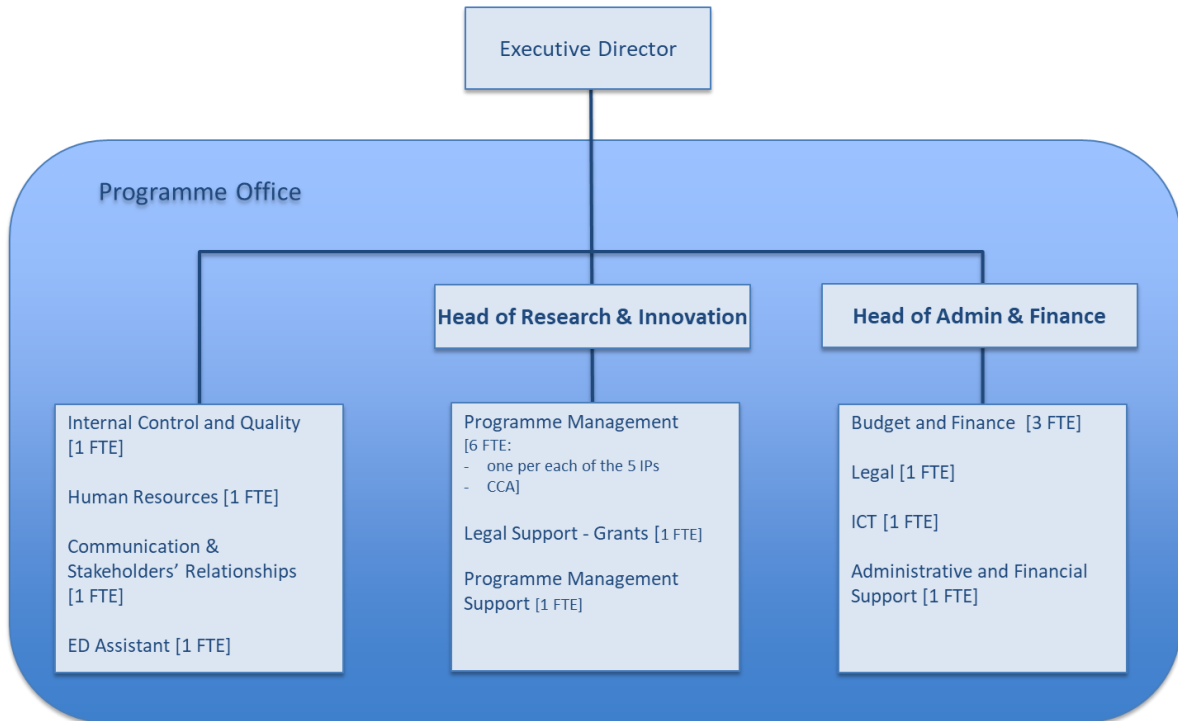

New organisational structure adopted on 01/03/2022

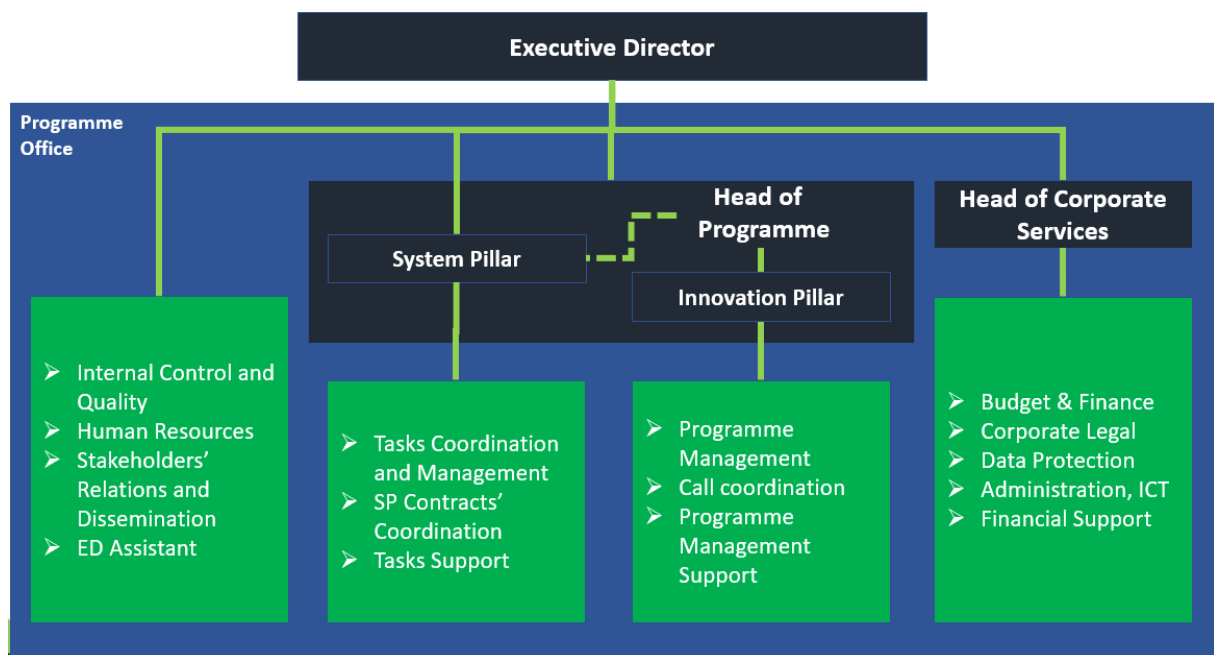

ANNEX B Establishment plan

The Authorized Budget indicated in the tables below refers to the staffing of the Europe's Rail Joint Undertaking which started its activities on 30 November 2021; consequently, the difference in the actually filled positions is attributable to the fact that it was not possible to recruit the staff and fill in the positions by the end of 2021. Recruitments have been launched and all positions are expected to be filled by Q3 2022.

Function group and grade	2019		2020		2021	
	Authorised under the EU Budget	Filled as of 31/12/2019	Authorised under the EU Budget	Filled as of 31/12/2020	Authorised under the EU Budget	Filled as of 31/12/2021
	Temporary posts	Temporary posts	Temporary posts	Temporary posts	Temporary posts	Temporary posts
AD 16						
AD 15					1	
AD 14	1	1	1	1		1
AD 13						
AD 12						
AD 11						
AD 10					2	2
AD 9	2	2	2	2	1	
AD 8	1	1	1	1	1	1
AD 7	1	1	1	1		1
AD 6					4	
AD 5					1	
AD TOTAL	5	5	5	5	10	5
AST 1-11						
AST TOTAL						
AST/SC 1-6						
AST/SC TOTAL						
TOTAL	5	5	5	5	10	5
GRAND TOTAL	5	5	5	5	10	5

Contract agents	Authorised 2019	Filled as of 31/12/2019	Authorised 2020	Filled as of 31/12/2020	Authorised 2021	Filled as of 31/12/2021
Function Group IV	12	13 ⁵⁸	12	13 ⁵⁹	13	13
Function Group III	3	3	3	2	3	3
Function Group II	1	1	1	1	1	1
Function Group I						
TOTAL	16	17	16	17	17	17

⁵⁸ 1 additional FG IV is included for initial period of one year, with possible extension for one additional year. Such recruitment is within the budget availability of S2R to replace the activities covered by a TA, absent due to a serious long term sickness leave, with a new contract running from December 2019 to December 2020. It is important to mention that the associated tasks could in no circumstances be wholly or partially allocated to any internal staff (segregation of duties and conflict of interest) nor be covered by an external interim agent or consultant in compliance with the EU Financial Rules.

⁵⁹ 1 additional FG IV renewed for an additional 1 year-period.

	Authorised 2019	Filled as of 31/12/2019	Authorised 2020	Filled as of 31/12/2020	Authorised 2021	Filled as of 31/12/2021
SNEs	2	2	2	3	2	1

ANNEX C Indicators and Scoreboard of KPIs

TABLE I - Horizon 2020 Key Performance Indicators⁶⁰ common to all JUs

	Correspondence to general Annex 1	Key Performance Indicator	Definition/Responding to question	Type of data required	Data to be provided by	Baseline at the start of H2020 (latest available)	Target at the end of H2020	Automated	Result 2021
INDUSTRIAL LEADERSHIP	12*	SME - Share of participating SMEs introducing innovations new to the company or the market (covering the period of the project plus three years);	Based on Community Innovation Survey (?). Number and % of participating SMEs that have introduced innovations to the company or to the market	Number of SMEs that have introduced innovations;	H2020 beneficiaries through project reporting	N/A [new approach under H2020]	50%	Yes	136 (53%)
	13	SME - Growth and job creation in participating SMEs	Turnover of company, number of employees	Turnover of company, number of employees;	H2020 beneficiaries through project reporting	N/A [new approach under H2020]	To be developed based on FP7 ex-post evaluation and /or first H2020 project results	Yes	N/A
SOCIETAL CHALLENGES	14*	Publications in peer-reviewed high impact journals in the area of the JU	The percentage of papers published in the top 10% impact ranked journals by subject category	Publications from relevant funded projects (DOI: Digital Object Identifiers); Journal impact benchmark (ranking) data to be collected by commercially	H2020 beneficiaries through project reporting; Responsible Directorate/Service (via access to appropriate	N/A [new approach under H2020]	[On average, 20 publications per €10 million funding (for all societal challenges)]	Yes	449

⁶⁰ Based on Annex II to Council Decision 2013/743/EU

	Correspondence to general Annex 1	Key Performance Indicator	Definition/Responding to question	Type of data required	Data to be provided by	Baseline at the start of H2020 (latest available)	Target at the end of H2020	Automated	Result 2021
				available bibliometric databases.	bibliometric databases)				
	15*	Patent applications and patents awarded in the area of the JU	Number of patent applications by theme; Number of awarded patents by theme	Patent application number	H2020 beneficiaries through project reporting; Responsible Directorate/Service (via worldwide search engines such as ESPACENET, WOPI)	N/A [new approach under H2020]	On average, 2 per €10 million funding (2014 - 2020) RTD A6	Yes	4
	16*	Number of prototypes testing activities and clinical trials	Number of prototypes, testing (feasibility/demo) activities, clinical trials	Reports on prototypes, and testing activities, clinical trials	H2020 beneficiaries through project reporting	N/A [new approach under H2020]	[To be developed on the basis of first Horizon 2020 results]	Yes	438
	17*	Number of joint public-private publications in projects	Number and share of joint public-private publications out of all relevant publications	Properly flagged publications data (DOI) from relevant funded projects	H2020 beneficiaries through project reporting; Responsible Directorate/Service (via DOI and manual data input-flags)	N/A [new approach under H2020]	[To be developed on the basis of first Horizon 2020 results]	Yes	39

	Correspondence to general Annex 1	Key Performance Indicator	Definition/Responding to question	Type of data required	Data to be provided by	Baseline at the start of H2020 (latest available)	Target at the end of H2020	Automated	Result 2021
	18*	New products, processes, and methods launched into the market	Number of projects with new innovative products, processes, instruments, methods, technologies	Project count and drop-down list allowing to choose the type processes, products, instruments, methods, technologies	H2020 beneficiaries through project reporting	N/A [new approach under H2020]	[To be developed on the basis of first Horizon 2020 results]	Yes	50
EVALUATION	N/A	Time to inform (average time in days) <u>all applicants</u> of the outcome of the evaluation of their application from the final date for submission of completed proposals	To provide applicants with high quality and timely evaluation results and feedback after each evaluation step by implementing and monitoring a high scientific level peer-reviewed process	Number of days (average)	Joint Undertaking	H2020		Yes	all calls (TTI): average 94 / Maximum 176 2021 call (TTI): 42
	N/A	Time to inform (average time in days) <u>successful applicants</u> of the outcome of the evaluation of their application from the final date for submission of completed proposals		Number of days (average)	Joint Undertaking	H2020		Yes	all calls (TTI): average 94 / Maximum 176 2021 call (TTI): 42
	N/A	Redress after evaluations	To provide applicants with high quality and timely evaluation results and feedback after each evaluation step by implementing and monitoring a high scientific level peer-reviewed process	Number of redresses requested	Joint Undertaking	H2020			none

	Correspondence to general Annex 1	Key Performance Indicator	Definition/Responding to question	Type of data required	Data to be provided by	Baseline at the start of H2020 (latest available)	Target at the end of H2020	Automated	Result 2021
GRANTS	N/A	Time to grant (average) measured from call deadline to signature of grants	To minimise the duration of the granting process aiming at ensuring a prompt implementation of the Grant Agreements through a simple and transparent grant preparation process	Average in days under H2020 TTG < 270 days (as % of GAs signed)	Joint Undertaking	H2020		Yes	all calls (TTG): average 191 2021 call (TTG): 140
	N/A	Time for signing grant agreements from the date of informing successful applicants (average values)		Average in days under H2020	Joint Undertaking	H2020		Yes	all calls (TTS): average 94 2021 call (TTS): 99
AUDITS	N/A	Error rate		Representative error in %; residual error in %	CAS	H2020	The residual error rate should be within the threshold of 2%	No	representative error of 2,27% for the JU (weighted average); residual error of 1,33% for the JU (weighted average)
	N/A	Implementation of ex-post audit results		Number of cases implemented; in total €million; Number of cases implemented/total cases	CAS	H2020		No	59 implemented cases, EUR 0,24 million 87% of total cases

	Correspondence to general Annex 1	Key Performance Indicator	Definition/Responding to question	Type of data required	Data to be provided by	Baseline at the start of H2020 (latest available)	Target at the end of H2020	Automated	Result 2021
PAYMENTS	N/A	Time to pay (% made on time) -pre-financing - interim payment -final payment	To optimize the payments circuits, both operational and administrative, including payments to experts	Average number of days for Grants pre-financing, interim payments and final payments; Average number of days for administrative payments; Number of experts appointed	Joint Undertaking	H2020	-pre-financing (30 days) - interim payment (90 days) -final payment (90days)	Yes	Operational: Pre-financing: 3 (100%) Average number of days: 17 Interim/final: 39 (90%) Average number of days: 79 Administrative: Interim/final: 456 (98,67%) Average number of days: 15 4
HR	N/A	Vacancy rate (%)		post filled in %, composition of the JU staff ⁶¹	Joint Undertaking	H2020			85%

⁶¹ Additional indicators can be proposed/discussed with R.1 and/or DG HR

	Correspondence to general Annex 1	Key Performance Indicator	Definition/Responding to question	Type of data required	Data to be provided by	Baseline at the start of H2020 (latest available)	Target at the end of H2020	Automated	Result 2021
JU EFFICIENCY	N/A	Budget implementation/execution : 1. % CA to total budget 2. % PA to total budget	Realistic yearly budget proposal, possibility to monitor and report on its execution, both in commitment (CA) and payments (PA), in line with sound financial management principle	% of CA and PA	Joint Undertaking	H2020	100% in CA and 90% in PA	Yes	CA: 100% PA: 85,2%
	N/A	Administrative Budget: Number and % of total of late payments	Realistic yearly budget proposal, possibility to monitor and report on its execution in line with sound financial management principle	Number of delayed payments % of delayed payments (of the total)	Joint Undertaking		H2020	Yes	10 late payments 2%

NOTES:

12,14,15,16,17,18*: The upcoming Control Gates (April) and project Reviews could generate improved data for this KPI which is cumulative on the S2R running projects in 2022.

18*: This indicator is not a legally compulsory one, but it covers several additional specific indicators requested for more societal challenges by the services in charge.

TABLE II - Indicators for monitoring H2020 Cross-Cutting Issues⁶² common to all JTI JUs

Correspondence to the general Annex 2	Cross-cutting issue	Definition/Responding to question	Type of data required	Data to be provided by	Data to be provided in/to	Direct contribution to ERA	Automated	Result 2021
2	Widening the participation	2.1 Total number of participations by EU-28 Member State	Nationality of H2020 applicants & beneficiaries (number of countries)	H2020 applicants & beneficiaries at the submission and grant agreement signature stage	JU AAR RTD Monitoring Report	Yes	Yes	20 applicants from 9 Member States 12 beneficiaries from 5 Member States in proposal retained for funding
		2.2 Total amount of EU financial contribution by EU-28 Member State (EUR millions)	Nationality of H2020 beneficiaries and corresponding EU financial contribution	H2020 beneficiaries at grant agreement signature stage	JU AAR RTD Monitoring Report	Yes	Yes	EUR 1,77 million from 5 Member States
N/A		Total number of participations by Associated Countries	Nationality of H2020 applicants & beneficiaries (number of countries)	H2020 applicants & beneficiaries at the submission and grant agreement signature stage	JU AAR RTD Monitoring Report	Yes	Yes	At the submission: 1 applicant from 1 country In the signed grant agreements: no Beneficiaries from Associated Countries
N/A		Total amount of EU financial contribution by Associated Country (EUR millions)	Nationality of H2020 beneficiaries and corresponding EU financial contribution	H2020 beneficiaries at grant agreement signature stage	JU AAR RTD Monitoring Report	Yes	Yes	N/A

⁶² Based on Annex III to Council Decision 2013/743/EU

Correspondence to the general Annex 2	Cross-cutting issue	Definition/Responding to question	Type of data required	Data to be provided by	Data to be provided in/to	Direct contribution to ERA	Automated	Result 2021
3	SMEs participation	3.1 Share of EU financial contribution going to SMEs (Enabling & industrial tech and Part III of Horizon 2020)	Number of H2020 beneficiaries flagged as SME; % of EU contribution going to beneficiaries flagged as SME	H2020 beneficiaries at grant agreement signature stage	JU AAR RTD Monitoring Report		Yes	1 SME Beneficiary benefiting from 6% of the total contribution
6	Gender	6.1 Percentage of women participants in H2020 projects	Gender composition of participants in H2020 projects	H2020 Beneficiaries throughout project reporting		Yes	Yes	13,6% of applicants 16,6% among beneficiaries
		6.2 Percentage of women project coordinators in H2020	Gender of MSC fellows, ERC principle investigators and scientific coordinators in other H2020 activities	H2020 beneficiaries at the grant agreement signature stage		Yes	Yes	20%
		6.3 Percentage of women in EC advisory groups, expert groups, evaluation panels, individual experts, etc.	Gender composition of memberships in advisory groups, panels, etc.	Compiled by Responsible Directorate/ Service /Joint Undertaking based on existing administrative data made available by the CSC		Yes	No	JU Governing Board: 10% of representatives are female among the GB members, 13% among all members including alternates EU-Rail Governing Board: 11% of representatives are female among the GB members, 6% among all members including alternates - JU States Representatives Group: 33% of representatives are female

Correspondence to the general Annex 2	Cross-cutting issue	Definition/Responding to question	Type of data required	Data to be provided by	Data to be provided in/to	Direct contribution to ERA	Automated	Result 2021
								- JU Scientific Committee: 33% of members are female
7	International cooperation	7.1 Share of third-country participants in Horizon 2020	Nationality of H2020 beneficiaries	H2020 beneficiaries at the grant agreement signature stage	JU AAR RTD Monitoring Report	No	Yes	0%
		7.2 Percentage of EU financial contribution attributed to third country participants	Nationality of H2020 beneficiaries and corresponding EU financial contribution	H2020 beneficiaries at the grant agreement signature stage	JU AAR RTD Monitoring Report	No	Yes	0%
9	Bridging from discovery to market ⁶³	9.1 Share of projects and EU financial contribution allocated to Innovation Actions (IAs)	Number of IA projects	Project Office – at GA signature stage he/she will be required to flag in SyGMA. Responsible Directorate/Service (WP coordinator)/Joint Undertaking - via tool CCM2	JU AAR RTD Monitoring Report		Yes	50% (Share of Projects) 10% (share of financial contribution)

⁶³ The indicator 9.2 initially intended to monitor the Digital Agenda (its applicability could be limited)

Correspondence to the general Annex 2	Cross-cutting issue	Definition/Responding to question	Type of data required	Data to be provided by	Data to be provided in/to	Direct contribution to ERA	Automated	Result 2021
		9.2 Within the innovation actions, share of EU financial contribution focused on demonstration and first-of-a-kind activities	Topics properly flagged in the WP; follow-up at grant level	Responsible Directorate/Service (WP coordinator)/Joint Undertaking - via tool CCM2	JU AAR RTD Monitoring Report		Yes	100%
N/A		10 Scale of impact of projects (High Technology Readiness Level)	Number of projects addressing TRL ⁶⁴ between 4-6 and 5-7	Joint Undertaking	JU AAR RTD Monitoring Report		No	TRL 4-6 (incl. projects up to TRL 4): 2 TRL 5-7: 0 Total: 2
11	Private sector participation	11.1 Percentage of H2020 beneficiaries from the private for profit sector	Number of and % of the total H2020 beneficiaries classified by type of activity and legal status	H2020 beneficiaries at grant agreement signature stage	JU AAR RTD Monitoring Report		Yes	7 beneficiaries 50% of the total beneficiaries
		11.2 Share of EU financial contribution going to private for profit entities (Enabling & industrial tech and Part III of Horizon 2020)	H2020 beneficiaries classified by type of activity; corresponding EU contribution	H2020 beneficiaries at grant agreement signature stage	JU AAR RTD Monitoring Report		Yes	74% of the total contribution

⁶⁴ TRL: Technology Readiness Level

Correspondence to the general Annex 2	Cross-cutting issue	Definition/Responding to question	Type of data required	Data to be provided by	Data to be provided in/to	Direct contribution to ERA	Automated	Result 2021
12	Funding for PPPs	12.1 EU financial contribution for PPP (Art 187)	EU contribution to PPP (Art 187)	Responsible Directorate/Service	JU AAR RTD Monitoring Report		Yes	EUR 41,4M
		12.2 PPPs leverage: total amount of funds leveraged through Art. 187 initiatives, including additional activities, divided by the EU contribution	Total funding made by private actors involved in PPPs - in-kind contribution already committed by private members in project selected for funding - additional activities (i.e. research expenditures/investment of industry in the sector, compared to previous year)	Joint Undertaking Services	JU AAR RTD Monitoring Report			129% 174%
13	Communication and dissemination	13.3 Dissemination and outreach activities other than peer-reviewed publications - [Conferences, workshops, press releases, publications, flyers, exhibitions, trainings, social media, websites, communication	A drop-down list allows to choose the type of dissemination activity. Number of events, funding amount and number of persons reached thanks to the dissemination activities	H2020 Beneficiaries throughout project reporting	JU AAR RTD Monitoring Report	Yes	Yes	3.304 Dissemination and outreach activities other than peer-reviewed publications People reached: 1.019.420

Correspondence to the general Annex 2	Cross-cutting issue	Definition/Responding to question	Type of data required	Data to be provided by	Data to be provided in/to	Direct contribution to ERA	Automated	Result 2021
		campaigns (e.g radio, TV)]						
14	Participation patterns of independent experts	14.2 Proposal evaluators by country	Nationality of proposal evaluators	Responsible Directorate /Service/Joint Undertaking in charge with the management of proposal evaluation			Yes	4 experts (3 from 3 EC Member States + 1 from Associated Countries)
		14.3 Proposal evaluators by organisations' type of activity	Type of activity of evaluators' organisations	Responsible Directorate /Service/Joint Undertaking in charge with the management of proposal evaluation			Yes	Extract from S2R Experts Pool statistics 

Correspondence to the general Annex 2	Cross-cutting issue	Definition/Responding to question	Type of data required	Data to be provided by	Data to be provided in/to	Direct contribution to ERA	Automated	Result 2021
N/A	Participation of RTOs and Universities	Participation of RTOs ⁶⁵ and Universities in PPPs (Art 187 initiatives)	Number of participations of RTOs to funded projects and % of the total Number of participations of Universities to funded projects and % of the total % of budget allocated to RTOs and to Universities	H2020 beneficiaries at the grant agreement signature stage	JU AAR RTD Monitoring Report	Yes	Yes	4 participations of RTOs 28% of total 2 participations of Universities 14 % of total 23% of total budget allocated to RTOs and Universities
N/A	Ethics	The objective is ensuring that research projects funded are compliant with provisions on ethics	% of proposals not granted because non-compliance with ethical rules/proposals invited do grant (target 0%); time to ethics clearance (target 45 days) ⁶⁶	Responsible Directorate /Service/Joint Undertaking	JU AAR RTD Monitoring Report			0%

Notes:

*H2020 applicants - all those who submitted H2020 proposals

*H2020 beneficiaries - all those who have signed a H2020 Grant Agreement

⁶⁵ RTO: Research and Technology Organisation

⁶⁶ Data relates to pre-granting ethics review. This time span runs in parallel to granting process.

TABLE III - Key Performance Indicators specific for EU-Rail

#	Key Performance Indicator	Objective	Data to be provided by	Baseline at the start of H2020	Target at the end of H2020	Automated	Result 2021
EU-Rail							
1	% reduction in the costs of developing, maintaining, operating and renewing infrastructure and rolling stock and increase in energy efficiency compared to "State-of-the-art"	Reduce the life-cycle cost of the railway transport system	JU	"State-of-the-art" 2014	> 50 %	No	See table IV
2	% increase the capacity of railway segments to meet increased demand for passenger and freight railway services compared to "State-of-the-art" 2014	Enhance the capacity of the railway transport system	JU	"State-of-the-art" 2014	100%	No	See table IV
3	% decrease in unreliability and late arrivals compared to "State-of-the-art" 2014	Increase in the quality of rail services	JU	"State-of-the-art" 2014	> 50%	No	See table IV
4	Reduce noise emissions and vibrations linked to rolling stock and respectively infrastructure compared to "State-of-the-art" 2014	Reduce the negative externalities linked to railway transport	JU	"State-of-the-art" 2014	> 3 - 10 dBA	No	TD1.4 Running gear works which, that with active suspension and new materials, estimate a reduction of the rolling noise of - 2dB.

#	Key Performance Indicator	Objective	Data to be provided by	Baseline at the start of H2020	Target at the end of H2020	Automated	Result 2021
							<p>TD3.4 – 4- 5 dB from the rail noise and -2 to 3 dB on overall noise thanks to absorptive panels (IN2TRACK-2)</p> <p>TD3.5 - 5dB in significant frequencies on bridge noise when damping was added on the steel structure of the bridge (Assets4rail)</p>
5	Addressing open points in TSIs, compared to "State-of-the-art" 2014	Enhance interoperability of the railway system	JU	"State-of-the-art" 2014		No	One open point of the TSI Infra (tender with input IN2TRACK-2/3)
6	Number of Integrated Technology Demonstrators (ITDs) and System Platform Demonstrations (SPD)	Improve market uptake of innovative railway solutions through large-scale demonstration activities	JU	Multi-Annual Action Plan	4 SPD	No	<p>ITD 3.6, 3.7 and 3.8 - in nine Use Cases of IN2SMART-2</p> <p>ITD 4.7 - COHESIVE Beta Release and Shift2MaaS pilots in Lisbon, Málaga</p>

#	Key Performance Indicator	Objective	Data to be provided by	Baseline at the start of H2020	Target at the end of H2020	Automated	Result 2021
							and Central-East corridor.
7	Share of the fund allocated to the different Innovation Programmes and to cross-cutting themes	Ensure that funding covers the railway system as a whole	JU	N/A	> 80%	No	100% of the operational funding
8	Percentage of topics resulting in signature of GA	Ensure a sufficiently high call topics success rate	JU	N/A	> 90%	Yes	signed 2 of 2 100%
9	% of resources consumption versus plan (members only)	WP execution by members - resources	JU	N/A	> 80%	Yes	*
10	% of deliverables available versus plan (members only)	WP execution by members - deliverables	JU	N/A	> 80%	No	91,8% - 2015-2020 71,3% - 2020 72,7% - 2021

TABLE IV – Initial Estimation – Release 4 - of the Key Performance Indicators of the Shift2Rail Programme

SPD	LCC	Capacity	Punctuality
Target	-50%	+100%	+50%
High Speed	-21% <small>-20%</small> <small>-15%</small> <small>-18%</small>	58% <small>62%</small> <small>69%</small> <small>74%</small>	35% <small>35%</small> <small>29%</small> <small>19%</small>
Regional	-32% <small>-37%</small> <small>-21%</small> <small>-24%</small>	90% <small>74%</small> <small>57%</small> <small>49%</small>	53% <small>53%</small> <small>51%</small> <small>15%</small>
Metro	-18% <small>-18%</small> <small>-16%</small> <small>-18%</small>	21% <small>25%</small> <small>23%</small> <small>28%</small>	n/a
Freight	-40% <small>-39%</small> <small>-39%</small> <small>-40%</small>	87% <small>94%</small> <small>42-114%</small> <small>91%</small>	57% <small>57%</small> <small>78%</small> <small>71%</small>

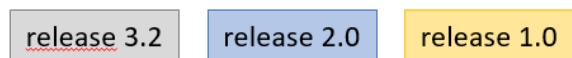

One of the objectives of the Shift2Rail Joint Undertaking defined in its regulation is to seek developing, integrating, demonstrating and validating innovative technologies and solutions that uphold the strictest safety standards and the value of which can be measured against, inter alia, 3 quantitative Key Performance Indicators (KPIs). The targets defined are the following: reduction of LCC by 50%, improving the reliability & punctuality by 50% and doubling the capacity.

As the railway system is a very interlinked and complex system, it is required to have specific tools and methods to evaluate the effect of technological developments. This question is highly relevant for Shift2Rail as the technologies, which are developed, are to be evaluated with respect to four scenarios

called System Platform Demonstrators (SPDs). Hence an approach of estimating the above mentioned KPIs applied on the four generic SPDs based on the market segments high-speed rail, regional rail, metro and freight rail⁶⁷ has been applied which were defined in the S2R Master Plan⁶⁸.

As some of the Shift2Rail technologies (e.g. Innovation Programme on IT Solutions for Attractive Railway Services) are targeting to increase modal share of rail within the transport sectors by satisfying the customer's travel experience, those innovations cannot be taken directly into account in the three quantitative KPIs, only via an increased load factor. Therefore, a dedicated model on the improvement of the attractiveness of the rail system is developed independent from the model discussed here (see also explanations to "demand effect").

In 2021, the Release 4 of the KPI model was published. In 2021, an in-depth review was carried out by each Innovation Programme which included closing of the open points from the model development. After Release 4, the model is frozen and in the following year, the collection of updated improvement values is planned.

The Accuracy of the improvement data was developed for Release 3 to increase the robustness of the model. In Release 4, the reported numbers of data set linked to the accuracy level and the values of the accuracy level increased.

The improvement values of the LCC KPI have not changed significantly. The slight changes in the LCC model are due to updated LCC improvement values for Journey Energy Usage and due to increased maturity of the developments within the TDs. Therefore, more accurate improvement values can be provided. The improvement values of the Capacity KPI were linked to the updated benefits coming from virtual coupling. By introducing this technology, the coupling time will be reduced and hence the capacity of the larger stations in peak hour will be increased and the required time and frequency for maintenance is improved. The result for the Punctuality KPI remained the same as during the last release.

⁶⁷ IMPACT-1 – D4.1 "Reference Scenario" – 2018, Issue 1

⁶⁸ Shift2Rail - Shift2Rail Master Plan (MP) – 2015

Key Performance Indicators - KPI

The KPI Life-Cycle-Cost (LCC) is defined as the cost for the railway undertaking over the lifespan of the systems. Hence, they are the investment cost, operative cost like maintenance, labour or energy cost and, where applicable, the dismantling cost.

The KPI Capacity is defined as the maximum possible capacity, which is the maximum number of transportable passengers in one peak hour for the passenger transport scenarios and the maximum of tonne-kilometres in 24 hours for freight.

The KPI Reliability and Punctuality is measured as a 50% decrease of late arrivals mainly caused by unreliability of technologies.

System Platform Demonstrators - SPDs

The reference scenarios (state of the art technologies in 2013) described in the deliverable D4.1 “Reference Scenarios” of IMPACT-1 and were further developed in IMPACT-2. The data for these scenarios were collected from various sources whereas usually there could only one source for each certain parameter be found. The coherence check is scheduled for the next iteration of the model.

Further there are aspects for the four different market segments of the SPDs, which need to be kept in mind, when reviewing the result table. Those aspects are due to the inherent structure and specificities of the different market segments:

For the High-Speed passenger transport (SPD1), relatively new or constantly upgraded vehicles and lines are taken into account, which are more or less best of class in Europe. Therefore, it is on the one hand a much-elaborated basis to start from and on the other hand it can be assumed that effects at less developed railways will show much higher results.

The main relevant KPIs for typically Regional Rail (SPD2) lines are LCC and punctuality. Hence the challenge is here to provide a punctual service at lower cost.

Concerning Metro Rail (SPD3), there are few activities dedicated directly on Metro in direct relation to the specific S2R JU objectives in the short term. Therefore, the results for Metro are mainly based on positive effects of the innovations developed for High Speed or Regional trains as e.g. reduction of energy consumption or improved maintenance. They are not optimised for this special form of rail transport but can help to reduce LCC and improve capacity.

Because SPD4, Freight rail, is not focussing on passenger transport, but freight transport, it differs in some definitions and focus points from the other three SPDs. Further the modelling has not only to consider technological improvements, but also operational optimisation for rail freight transport. Moreover, as generally the introduction of innovations in freight rail operation takes more time than in passenger transport, the technology level in execution is quite

moderate. Taking both into account, the more legacy basis to start from and the technological and operational effects, the achievable benefits are much higher than for the other three SPDs.

Furthermore, some innovations cannot show their full potential, because there is only one scenario per market segment. Those scenarios are optimised to show the majority of positive effects but cannot be set to show every effect of every Shift2Rail innovation.

Demand effect

As already explained in the background, large parts of positive effects especially for the passenger transport (SPD1-3) are not adequately measurable through LCC, capacity and punctuality, e.g. new IT solutions (IP4), effects of other innovations such as noise mitigation, customer oriented services and better quality, increased comfort for the customers, better governance etc. Those will be included in the attractiveness model. Therefore, the increase of demand is not considered in the results for the passenger SPDs, yet, meaning that for the first results there is no change in the load factor and therefore in the demand included. For the freight SPD, a demand increase could already be considered and therefore also its positive effect on the contribution margin.

ANNEX D Annual accounts

In line with the reporting requirement detail in FR 2018 Article 130.4, the Financial Framework Partnerships >4 years are reported under Section 1.3.3 of this document.

BALANCE SHEET

		EUR '000	
	Note	31.12.2021	31.12.2020
NON-CURRENT ASSETS			
<i>Intangible assets</i>		1	2
<i>Property, plant and equipment</i>	2.1	152	183
<i>Pre-financing</i>	2.2	9 167	50 271
		9 320	50 456
CURRENT ASSETS			
<i>Pre-financing</i>	2.2	67 410	46 049
<i>Exchange receivables and non-exchange recoverables</i>	2.3	40 277	40 598
		107 687	86 646
TOTAL ASSETS		117 006	137 102
CURRENT LIABILITIES			
<i>Payables and other liabilities</i>	2.4	(97 906)	(97 465)
<i>Accrued charges and deferred income</i>	2.5	(57 488)	(44 413)
		(155 394)	(141 878)
TOTAL LIABILITIES		(155 394)	(141 878)
NET ASSETS		(38 388)	(4 777)
<i>Contribution from Members</i>	2.6	528 779	428 922
<i>Accumulated deficit</i>		(433 698)	(311 031)
<i>Economic result of the year</i>		(133 469)	(122 667)
NET ASSETS		(38 388)	(4 776)

STATEMENT OF FINANCIAL PERFORMANCE

	Note	2021	2020
<i>EUR '000</i>			
REVENUE			
Revenue from non-exchange transactions			
<i>Recovery of expenses</i>	3.1	119	136
		119	136
Revenue from exchange transactions			
<i>Other</i>	3.2	16	33
		16	33
Total revenue		135	169
EXPENSES			
<i>Operational costs</i>	3.3	(130 157)	(119 355)
<i>Staff costs</i>	3.4	(1 840)	(1 914)
<i>Other expenses</i>	3.5	(1 606)	(1 568)
Total expenses		(133 604)	(122 836)
ECONOMIC RESULT OF THE YEAR		(133 469)	(122 667)

CASHFLOW STATEMENT⁶⁹

	2021	2020
<i>EUR '000</i>		
<i>Economic result of the year</i>	(133 469)	(122 667)
Operating activities		
<i>Depreciation and amortization</i>	55	52
<i>(Increase)/decrease in pre-financing</i>	19 743	(17 584)
<i>(Increase)/decrease in exchange receivables and non-exchange recoverables</i>	321	(14 282)
<i>Increase/(decrease) in payables</i>	441	16 719
<i>Increase/(decrease) in accrued charges & deferred income</i>	13 074	7 450
<i>Increase/(decrease) in cash contributions</i>	42 686	77 054
<i>Increase/(decrease) in in-kind contributions</i>	57 171	53 298
Investing activities		
<i>(Increase)/decrease in intangible assets and property, plant and equipment</i>	(23)	(40)
NET CASHFLOW	-	-
<i>Net increase/(decrease) in cash and cash equivalents</i>	-	-
<i>Cash and cash equivalents at the beginning of the year</i>	-	-
<i>Cash and cash equivalents at year-end</i>	-	-

⁶⁹ Following the appointment of the Accounting Officer of the Commission as the Accounting Officer of EU-Rail, the treasury of EU-Rail was integrated into the Commission's treasury system. Therefore, EU-Rail does not have any bank accounts of its own. All payments and receipts are processed via the Commission's treasury system and registered on intercompany accounts which are presented under the heading exchange receivables.

STATEMENT OF CHANGES IN NET ASSETS

	EUR '000			
	Contribution from Members	Accumulated Surplus/ (Deficit)	Economic result of the year	Net Assets
BALANCE AS AT 31.12.2019	298 570	(190 081)	(120 950)	(12 461)
<i>Allocation 2018 economic result</i>	-	(120 950)	120 950	-
<i>Cash contribution</i>	77 054	-	-	77 054
<i>Contribution in-kind</i>	53 298	-	-	53 298
<i>Economic result of the year</i>	-	-	(122 667)	(122 667)
BALANCE AS AT 31.12.2020	428 922	(311 031)	(122 667)	(4 776)
<i>Allocation 2019 economic result</i>	-	(122 667)	122 667	-
<i>Cash contribution</i>	42 686	-	-	42 686
<i>Contribution in-kind</i>	57 171	-	-	57 171
<i>Economic result of the year</i>	-	-	(133 469)	(133 469)
BALANCE AS AT 31.12.2021	528 779	(433 698)	(133 469)	(38 388)

ANNEX E Overview of publications and events

JU 2021 PUBLICATIONS

Title	Publication Date	Link to the Publication
Annual Activity Report 2020: Executive View	26 October 2021	https://shift2rail.org/wp-content/uploads/2021/10/AAR_S2R_2021-Digital.pdf
Shift2Rail Factsheet	10 October 2021	https://shift2rail.org/wp-content/uploads/2021/09/S2R_Factsheet_September-2021.pdf

JU 2021 PRESS RELEASES

Title	Publication Date	Link to the Publication
Shift2Rail Call for Proposals 2021: Participation Results	31 May 2021	https://shift2rail.org/press-releases/shift2rail-call-for-proposals-2021-participation-results/
Memorandum of Understanding signed between Shift2Rail Joint Undertaking, CEN and CENELEC	10 June 2021	https://shift2rail.org/press-releases/memorandum-of-understanding-signed-between-shift2rail-joint-undertaking-cen-and-cenelec/
Memorandum of Understanding signed between Shift2Rail Joint Undertaking and International Union of Railways	8 July 2021	https://shift2rail.org/press-releases/memorandum-of-understanding-signed-between-shift2rail-joint-undertaking-and-international-union-of-railways/
Shift2Rail awards two grants under its Call for Proposals 2021	16 July 2021	https://shift2rail.org/press-releases/shift2rail-awards-two-grants-under-its-call-for-proposals-2021/
European Digital Automatic Coupler: first step towards one type selection	21 September 2021	https://shift2rail.org/press-releases/european-digital-automatic-coupler-first-step-towards-one-type-selection/
Shift2Rail partners with the 4th edition of the European Startup Prize for Mobility	30 September 2021	https://shift2rail.org/press-releases/shift2rail-partners-with-the-4th-edition-of-the-european-startup-prize-for-mobility/
Winners of the joint Shift2Rail and Siemens Mobility hackathon Hack2Rail announced	29 October 2021	https://shift2rail.org/press-releases/winners-of-the-joint-shift2rail-and-siemens-mobility-hackathon-hack2rail-announced/

Regulation establishing Shift2Rail successor programme Europe's Rail enters into force	30 November 2021	https://shift2rail.org/press-releases/regulation-establishing-shift2rail-successor-programme-europes-rail-enters-into-force/
--	------------------	---

JU 2021 NEWSLETTER

Title	Publication Date	Link to the Publication
Interview with newly appointed Programme Managers of EDDP	29 January 2021	https://mailchi.mp/s2r.europa.eu/january2021newsletter
Shift2Rail's Successor – Europe's Rail – Officially Proposed for Adoption	26 February 2021	https://mailchi.mp/s2r.europa.eu/february2021newsletter
Connecting Europe Express coming near you soon!	31 March 2021	https://mailchi.mp/s2r.europa.eu/march2021newsletter
Game-changing Silicon Carbide Technology for Traction Systems	30 April 2021	https://mailchi.mp/s2r.europa.eu/april2021newsletter
Europe's Rail leadership, #ConnectingEurope Express and more	31 May 2021	https://mailchi.mp/s2r.europa.eu/may2021newsletter
Accelerating the deployment of ERTMS	30 June 2021	https://mailchi.mp/s2r.europa.eu/june2021newsletter
Join our Shift2Rail hackathon "Hack2Rail"	29 September 2021	https://mailchi.mp/s2r.europa.eu/september2021newsletter
Hack2Rail Demo Day - Join us live on 29 October	28 October 2021	https://mailchi.mp/s2r.europa.eu/october2021newsletter
Shift2Rail Innovation Days 2021 – Join us live on 9-10 December	25 November 2021	https://mailchi.mp/s2r.europa.eu/november2021newsletter
Shifting to Europe's Rail	17 December 2021	https://mailchi.mp/rail-research.europa.eu/december2021newsletter

PRESS ARTICLES ABOUT JU PUBLISHED IN 2021

Press outlet	Title	Link to the Publication	
International Railway Journal	Skills for the next-generation rail industry	https://www.railjournal.com/in_depth/skills-next-generation-rail-industry	
	Rail set to return upward trajectory	https://www.railjournal.com/in_depth/rail-set-to-return-upward-trajectory	
	No silver bullet to increase rail's market share to 30%	https://www.railjournal.com/in_depth/no-silver-bullet-to-increase-rails-market-share-to-30	
	European Commission approves Shift2Rail successor, Europe's Rail	https://www.railjournal.com/policy/european-commission-approves-shift2rail-successor-europes-rail/	
	Making the connection with digital couplings	https://www.railjournal.com/in_depth/making-the-connection-with-digital-couplings	
	Automatic Track Machine Oscillator track maintenance unit unveiled	https://www.railjournal.com/infrastructure/automatic-track-machine-oscillator-track-maintenance-unit-unveiled/	
	Shift2Rail cybersecurity project achieves mid-term objectives	https://www.railjournal.com/technology/shift2rail-cybersecurity-project-achieves-mid-term-objectives/	
	Shift2Rail project develops digital tests for GNSS-based ETCS	https://www.railjournal.com/news/shift2rail-project-develops-digital-tests-for-gnss-based-etcs/	
	60 years of railway progress and counting	https://www.railjournal.com/opinion/60-years-of-railway-progress-and-counting	
	Unlocking network capacity	https://www.railjournal.com/in_depth/unlocking-network-capacity	
	All aboard for Europe's Rail	https://www.railjournal.com/in_depth/all-aboard-for-europes-rail/	
	Shift2Rail issues call for proposals for two projects	https://www.railjournal.com/fleet/shift2rail-issues-call-for-proposals-for-two-projects/	
	A new era beckons for railway research	https://www.railjournal.com/opinion/a-new-era-beckons-for-railway-research	
	Atmo brings rail grinding to tight urban tracks	https://www.railjournal.com/in_depth/atmo-brings-rail-grinding-to-tight-urban-tracks	
	Building tomorrow's innovative rolling stock	https://www.railjournal.com/opinion/building-tomorrows-innovative-rolling-stock	
	Global Railway Review	Scharfenberg digital coupler chosen for DAC programme	https://www.railjournal.com/freight/scharfenberg-digital-coupler-chosen-for-dac-programme/
		Connecting Europe Express completes 20,000km journey to Paris	https://www.railjournal.com/regions/europe/connecting-europe-express-completes-20000km-journey-to-paris/
Global Railway Review	Europe's Rail approved by Council of the European Union	https://www.railjournal.com/policy/europes-rail-approved-by-council-of-the-european-union/	
	The digitalisation of railways drives safer trains	https://www.globalrailwayreview.com/article/116558/huawei-digitalisation-railways-safer-trains/	
Global Railway Review	Shift2Rail's 4SECURail initiative achieves mid-term cybersecurity and signalling objectives	https://www.globalrailwayreview.com/news/117915/shift2rail-4securail-cyber-security-signalling-objectives/	

	Digital Automatic Couplers: Dellner's solution to coupling automation	https://www.globalrailwayreview.com/article/120804/dellner-digital-automatic-couplers/
	Shift2Rail signs MoU to accelerate European rail standardisation work	https://www.globalrailwayreview.com/news/124929/shift2rail-european-rail-standardisation/
Railway Gazette	Tests suggest 30% cost saving using distributed power with LTE	https://www.railwaygazette.com/freight/tests-suggest-30-cost-saving-using-distributed-power-with-lte/58726.article
	Automation test track takes shape	https://www.railwaygazette.com/technology/automation-test-track-takes-shape/58917.article
	Training & Skills: Supporting recovery and the EU Green Deal	https://www.railwaygazette.com/in-depth/training-and-skills-supporting-recovery-and-the-eu-green-deal/58898.article
	Shift2Rail, CEN and CENELEC sign standardisation co-operation agreement	https://www.railwaygazette.com/technology/shift2rail-cen-and-cenelec-sign-standardisation-co-operation-agreement/59304.article
	DAC programme selects Scharfenberg digital coupler	https://www.railwaygazette.com/technology/dac-programme-selects-scharfenberg-digital-coupler/59941.article
	Connecting Europe Express sets off on 26-country tour	https://www.railwaygazette.com/policy/connecting-europe-express-sets-off-on-26-country-tour/59821.article
	Diesel locomotives to be converted to hydrogen power	https://www.railwaygazette.com/traction-and-rolling-stock/diesel-locomotives-to-be-converted-to-hydrogen-power/60063.article
	New capabilities in safety and comfort – For railcars, the environment and your budget	https://www.railwaygazette.com/sponsored-content/new-capabilities-in-safety-and-comfort-for-railcars-the-environment-and-your-budget/60080.article
RailTech.com	DAC is a real game changer for the European Green Deal	https://www.railtech.com/innovation/2021/02/01/dac-is-a-real-game-changer-for-the-european-green-deal/
	Shift2Rail's successor Europe's Rail officially proposed by Commission	https://www.railtech.com/policy/2021/02/26/shift2rails-successor-europes-rail-officially-proposed-by-commission/
	What can we expect from Shift2Rail's innovation successor?	https://www.railtech.com/innovation/2021/10/06/what-can-we-expect-from-europes-rail-innovation-programme/
Business Wire	Akka: New Research & Innovation Project for the Reliability and Efficiency of Rail Traction Systems	https://www.businesswire.com/news/home/20210225005896/en/AKKA-NEW-RESEARCH-INNOVATION-PROJECT-FOR-THE-RELIABILITY-AND-EFFICIENCY-OF-RAIL-TRACTION-SYSTEMS
	Train Durability and Performance: AKKA Provides Its Cross-sectorial Expertise to the Gearbodies Project	https://www.businesswire.com/news/home/20210408005673/en/Train-Durability-and-Performance-AKKA-Provides-Its-Cross-sectorial-Expertise-to-the-Gearbodies-Project
Intelligent Transport	Laying the foundations for seamless multimodal travel across Europe	https://www.intelligenttransport.com/transport-articles/118443/shift2rail-interview/
Mass Transit Magazine	Plasser & Theurer release newly developed rail grinding machine for light rail and trams	https://www.masstransitmag.com/rail/maintenance/general-maintenance-products/press-release/21210436/plasser-theurer-plasser-

		<u>theurer-release-newly-developed-rail-grinding-machine-for-light-rail-and-trams</u>
Rail Freight	'Hyperloop should not cannibalise traditional railways'	<u>https://www.railfreight.com/railfreight/2021/05/07/hyperloop-should-not-cannibalise-traditional-railways/</u>
	835-metre long train from Germany to Sweden	<u>https://www.railfreight.com/railfreight/2021/05/03/835-metre-long-train-from-germany-to-sweden-for-the-first-time/</u>
Euronews	Train sets off on 20,000km trip across Europe to promote rail travel	<u>https://www.euronews.com/travel/2021/09/02/train-sets-off-on-20-000-km-trip-across-europe-to-promote-rail-travel</u>
	Paris-Berlin in 1 hour: is this the future of train travel in Europe? (in German)	<u>https://de.euronews.com/next/2021/09/15/paris-berlin-in-1-stunde-ist-das-die-zukunft-des-zugverkehrs-in-europa</u>
	Is it possible to go from Berlin to Paris in 1 hour by train? Maglev, magrail and hyperloop projects in the EU (in Turkish)	<u>https://tr.euronews.com/2021/09/16/berlin-den-paris-e-trenle-1-saatte-gidilebilir-mi-ab-deki-maglev-magrail-ve-hyperloop-proj</u>
	From Paris to Berlin in an hour: the future of high-speed rail in Europe (in Russian)	<u>https://ru.euronews.com/next/2021/09/15/ru-from-paris-to-berlin-by-train</u>
	Connecting Europe Express has arrived in Budapest (in Hungarian)	<u>https://hu.euronews.com/2021/09/19/budapestre-ert-a-connecting-europe-express</u>
	The floating train of the future can run at speeds of up to 1000 km/h (in Hungarian)	<u>https://hu.euronews.com/2021/09/16/akar-1000-kilometer-oras-sebesseggel-is-szaguldhat-a-jo-vo-lebego-vonata</u>
Rail Freight Forward	The S2R funded TRANSLATE4RAIL project breaking the language barrier	<u>https://www.railfreightforward.eu/node/71</u>
Railway Age	Europe's Rail, With Shift2Rail Executive Director Carlo Borghini: RAIL GROUP ON AIR	<u>https://www.railwayage.com/podcasts/europes-rail-with-shift2rail-executive-director-carlo-borghini-rail-group-on-air/</u>
The Brake Report	Spotlight on Rail During EuroBrake 2021	<u>https://thebrakereport.com/spotlight-on-rail-during-eurobrake-2021/</u>
Rynek Kolejowy	Nevomo part of the Dutch Hyperloop Development Program (in Polish)	<u>https://www.rynek-kolejowy.pl/mobile/nevomo-czescia-holenderskiego-hyperloop-development-program--100213.html</u>
	Rail Safety: It's okay, but it needs to be even better (in Polish)	<u>https://www.rynek-kolejowy.pl/mobile/bezpieczenstwo-kolei-jest-dobrze-ale-musi-byc-jeszcze-lepiej-101566.html</u>
	What should a modern driver's cab look like? (in Polish)	<u>https://www.rynek-kolejowy.pl/wiadomosci/jak-powinna-wygladac-nowoczesna-kabina-maszynisty-102075.html</u>
	A revolution in European rail freight traffic - CargoFlex for the digital age (in Polish)	<u>https://www.rynek-kolejowy.pl/mobile/rewolucja-w-europejskim-kolejowym-ruchu-towarowym--cargoflex-namiare-ery-cyfrowej-104658.html</u>
	What changes await us in the Technical Specifications for Interoperability? (in Polish)	<u>https://www.rynek-kolejowy.pl/mobile/utk-jakie-zmiany-w-tsi-w-przyszlym-roku-104468.html</u>
	Digitization as the future of railways. PKP SA announces a	<u>https://www.rynek-kolejowy.pl/mobile/cyfryzacja-przyszloscia-kolei-</u>

	comprehensive passenger application (in Polish)	pkp-sa-zapowiadaja-kompleksowa-aplikacje-pasazera-104599.html
The Construction Index	Polish hyperloop company sets out plans for 2021	https://www.theconstructionindex.co.uk/news/view/polish-hyperloop-company-sets-out-plans-for-2021
Railway Technology	Is cybersecurity in rail more important now than ever?	https://www.railway-technology.com/features/is-cybersecurity-rail-important-now-ever/
Inside GNSS	Increased Rail Role Urged for Galileo and EGNOS; GNSS Important for Europe's Green New Deal and Mobility Makeover	https://insidegnss.com/increased-rail-role-urged-for-galileo-and-egnos-important-for-europes-green-new-deal-and-mobility-makeover/
Baltic Transport Journal	Longer trains tested in Sweden	https://baltictransportjournal.com/index.php?id=1663
GIM International	EGNOS and Galileo Integral Part of EU Digital Rail Agenda	https://www.gim-international.com/content/news/egnos-and-galileo-integral-part-of-eu-digital-rail-agenda
eurisy	Space to drive the smart and green mobility transition	https://www.eurisy.eu/space-to-drive-the-smart-and-green-mobility-transition/
Journal General de l'Europe	Today, as in the past, SNCF continues to innovate to develop tomorrow's mobility	https://www.journalgeneraldeurope.org/en/2021/02/10/aujourd'hui-comme-hier-la-sncf-innovent-pour-inventer-la-mobilite-de-demain/
CISION	Indra Is About To Take The Plunge In Paris And Revolutionise Transport Payments In The French Capital	https://www.prnewswire.com/news-releases/indra-is-about-to-take-the-plunge-in-paris-and-revolutionise-transport-payments-in-the-french-capital-301305558.html
Deutsche Welle	A single European railway with Connecting Europe Express	https://www.dw.com/en/asingle-european-railway-with-connecting-europe-express/a-59062258
	Traveling the European Union on One Train? Connecting Europe Express is the answer (in Indonesian)	https://www.dw.com/id/keliling-uni-eropa-dengan-connecting-europe-express/a-59077675
Euractiv	A Future-Oriented Rail System for Europe: CEN, Cenelec and Shift2rail signed a Partnership Agreement	http://pr.euractiv.com/pr/future-oriented-rail-system-europe-cen-cenelec-and-shift2rail-signed-partnership-agreement-218307
EurekaAlert	STREAM Project: Towards Smart Tools for railway inspection and maintenance operations	https://www.eurekaalert.org/pub_releases/2021-02/iidt-spt020421.php
	The future on rails. The railway system - Styria as an international centre of research and innovation	https://www.eurekaalert.org/pub_releases/2021-06/guot-tfo062321.php
Urban Transport Magazine	Grinding rails for less noise: The new ATMO from Plasser & Theurer ensures smoother running	https://www.urban-transport-magazine.com/en/schienen-schleifen-leiser-fahren-die-neue-atmo-von-plasser-theurer-sorgt-fuer-mehr-laufruhe/
The European	Travel through Europe in the palm of your hand	https://the-european.eu/story-24213/travel-through-europe-in-the-palm-of-your-hand.html
TheMayor.eu	Constanze Bannholzer: Efficient freight rail transport is the key	https://www.themayor.eu/en/a/view/constanze-bannholzer-efficient-freight-rail-transport-is-the-

	for an economically competitive Europe	<u>key-for-an-economically-competitive-europe-8229</u>
The European Sting	European Year of Rail: Connecting Europe Express now leaving the station	<u>https://europeansting.com/2021/09/01/european-year-of-rail-connecting-europe-express-now-leaving-the-station/</u>
UITP	The Shift2MaaS project overcame barriers & borders to advance multimodal travel in Europe	<u>https://www.uitp.org/news/the-shift2maas-project-overcame-barriers-borders-to-advance-multimodal-travel-in-europe/</u>
Freight Waves	Home Depot offers freight rail a shipper wish list	<u>https://www.freightwaves.com/news/home-depot-offers-shipper-wish-list-for-rail-infrastructure</u>
CompositesWorld	Shift2Rail issues call for molding tools to produce composite door, interiors demonstrators	<u>https://www.compositesworld.com/news/shift2rail-issues-call-for-molding-tools-to-produce-composite-door-interiors-demonstrators</u>
Homeland Security Today	Cybersecurity Vital to Europe's Major Rail Transformation	<u>https://www.hstoday.us/subject-matter-areas/transportation/cybersecurity-vital-to-europes-major-rail-transformation/</u>
ftnNEWS	Connecting Europe Express Reached its Final Destination	<u>https://ftnnews.com/rail/42606-connecting-europe-express-reached-its-final-destination</u>
Schengenisainfo	Connecting Europe Express Train Starts Its Journey to Pass Through 100+ European Towns	<u>https://www.schengenisainfo.com/news/connecting-europe-express-train-starts-its-journey-to-pass-through-100-european-towns/</u>
	Connecting Europe Express Train Reaches Paris After Travelling for 36 Days Across EU	<u>https://www.schengenisainfo.com/news/connecting-europe-express-train-reaches-paris-after-travelling-for-36-days-across-eu/</u>
adnkronos	Indra is about to make the leap in quality in Paris, revolutionizing payments in the transport sector of the French capital (in Italian)	<u>https://www.adnkronos.com/indra-sta-per-fare-il-salto-di-qualita-a-parigi-rivoluzionando-i-pagamenti-nel-settore-dei-trasporti-della-capitale-francese_zC1fQXC8ZDj4YnZxgjmnr</u>
APA-OTS	Indra is about to take the plunge to Paris and revolutionize transport payments in the French capital (in German)	<u>https://www.ots.at/presseaussendung/OTS_20210604_OTS0134/indra-ist-dabei-den-sprung-nach-paris-zu-wagen-und-transportzahlungen-in-der-franzoesischen-hauptstadt-zu-revolutionieren</u>
Spoor Pro	Video: ATO over ETCS interoperability successfully tested in England (in Dutch)	<u>https://www.spoorpro.nl/innovatie/2021/04/23/video-interoperabiliteit-van-ato-over-etcs-met-succes-getest-in-engeland/</u>
	Shift2Rail is looking for innovations for digital automatic linking (in Dutch)	<u>https://www.spoorpro.nl/materieel/2021/04/22/shift2rail-roept-bedrijven-op-innovaties-in-tenzenden-voor-digitaal-automatisch-koppelen/</u>
	DB Cargo tested ATO on Switzerland's public rail network (in Dutch)	<u>https://www.spoorpro.nl/innovatie/2021/04/02/db-cargo-testte-ato-op-openbare-spoornet-zwitzerland/</u>
	First 835-meter freight train makes a test run from Germany to Sweden (in Dutch)	<u>https://www.spoorpro.nl/goederenvervoer/2021/05/03/eerste-835-meter-lange-goederentrein-maakt-testrit-van-duitsland-naar-zweden/?gdpr=accept</u>
Security Magazine	Projects To Strengthen Cybersecurity And Railway Signaling Move Forward (in Portuguese)	<u>https://www.securitymagazine.pt/2021/02/15/projectos-para-reforcar-ciberseguranca-e-sinalizacao-de-ferrovia-avancam/</u>

Via Libre	Progress of the project to reinforce cybersecurity and improve signaling 4SECURail (In Spanish)	https://www.vialibre-ffe.com/noticias.asp?not=30960
	Sixteenth Assembly of the Spanish Railway Technology Platform, PTFE (in Spanish)	https://www.vialibre-ffe.com/noticias.asp?not=33591
El Confidencial	Indra's role in R + D + i in Spain, National Innovation Award (in Spanish)	https://www.elconfidencial.com/empresas/2021-06-08/indra-premio-nacional-de-innovacion-2020-bra_3113907/
FerPress	Memorandum of Understanding signed between the Shift2Rail Joint Undertaking, CEN and CENELEC (in Italian)	https://www.ferpress.it/memorandum-dintesa-firmato-tra-limpresa-comune-shift2rail-e-cenelec/
	European Year of Railways: the Connecting Europe Express is ready to go (in Italian)	https://www.ferpress.it/anno-europeo-delle-ferrovie-il-connecting-europe-express-e-pronto-a-partire/
Agencia de Noticias Órbita	The kings of Spain present Indra with the national innovation award (in Spanish)	https://agenciaorbita.org/2021/06/15/los-reyes-de-espana-entregan-a-indra-el-premio-nacional-de-innovacion/
DVZ	Another billions for research in transport (in German)	https://www.dvz.de/rubriken/management-recht/nachhaltige-logistik/detail/news/eu-foerdert-weitere-forschungspartnerschaften-fuer-verkehr.html
	Budget for CEF is not convincing (in German)	https://www.dvz.de/rubriken/politik/detail/news/budget-fuer-cef-ueberzeugt-nicht.html
El Independiente	Indra receives the National Innovation Award in the large company category (in Spanish)	https://www.elindependiente.com/economia/2021/06/10/indra-recibe-el-premio-nacional-de-innovacion-en-la-categoria-de-gran-empresa/
Informationsdienst Wissenschaft e.V.	The future on rails: Complete rail system - Styria as an international research and innovation center (in German)	https://nachrichten.idw-online.de/2021/06/23/die-zukunft-auf-schiene-gesamtsystem-bahn-die-steiermark-als-internationales-forschungs-und-innovationszentrum/?groupcolor=5
The Busplanner	Public transport: new seating concept in the Grammer portfolio (in German)	https://www.busplaner.de/de/news/linienverkehr-oeffentlicher-personennahverkehr-oepnv-unternehmens-wirtschaft-und-branchen-nachrichten-sonst_oepnv-neues-sitzkonzept-im-grammer-portfolio-73528.html
Leadersnet	An ambassador for cross-border rail traffic stops in Vienna (in German)	https://www.leadersnet.at/news/52721,einbotschafter-fuer-grenzueberschreitenden-bahnverkehr-macht.html
La Tribune	SIFER: these innovations that could well upset the rail industry (in French)	https://www.latribune.fr/entreprises-finance/industrie/sifer-ces-innovations-qui-pourraient-bien-bouleverser-la-filiere-ferroviaire-895463.html
EconomyUp	European Startup Prize for Mobility: how the EU acceleration program for sustainable mobility works (in Italian)	https://www.economyup.it/mobilita/european-startup-prize-for-mobility-come-funziona-il-programma-di-accelerazione-ue/

Pitane Blue	Connecting Europe Express departs from Lisbon station (in Dutch)	https://pitane.blue/2021/09/02/connecting-europe-express-vertrekt-uit-station-van-lissabon/
Istoe Dinheiro	Putting Europe's future on track (in Portuguese)	https://www.istoedinheiro.com.br/colocando-nos-trilhos-o-futuro-da-europa/
IA RZD-Partner.ru	European Express will visit Riga on September 21 (in Russian)	https://www.rzd-partner.ru/zhd-transport/news/21-sentyabrya-rigu-posetit-evropeyskiy-ekspres/
Atalayar	Express train for Europe (in Spanish)	https://atalayar.com/content/tren-expreso-para-europa
HOY	Indra will implement its technology in the Plasencia-Badajoz section for 15 million euros (in Spanish)	https://www.hoy.es/extremadura/indra-implantara-tecnologia-20210829121847-nt.html
Domtotal	Europe seeks to make rail travel more attractive for passengers and companies (in Portuguese)	https://domtotal.com/noticia/1537166/2021/09/europa-busca-tornar-viagens-ferroviarias-mais-atraentes-para-passageiros-e-companhias/
Profit	The Connecting Europe Express train leaves for its inaugural journey tomorrow. Stops in Romania as well (in Romanian)	https://www.profit.ro/povesti-cu-profit/autotransporturi/trenul-connecting-europe-express-pleaca-maine-in-calatoria-inaugurala-opriri-si-in-romania-20380177
Svet Komunikacie	EU: Connecting Europe fast (in Slovak)	https://www.svet-komunikacie.sk/2021/09/eurychlik-spajajuci-europu.html
Delo	Update on tracks and in headers (in Slovenian)	https://www.delo.si/novice/slovenija/posodobite-v-na-tirih-in-v-glavah/
Skaties	Next week, the Baltic train dedicated to the European Railway Year will run from Tallinn to Vilnius (in Latvian)	https://skaties.lv/zinas/latvija/sabiedriba/nakam-nedel-no-tallinas-lidz-vilnai-kurses-eiropas-dzelzcela-gadam-veltitais-baltijas-vilciens/
Allt om Resor	The train of the future: Oslo – Stockholm in 30 minutes (in Swedish)	https://www.expressen.se/allt-om-resor/nyheter/framtidens-tag-oslo-stockholm-pa-30-minuter/
La Repubblica	The European Startup Prize for Mobility is underway (in Italian)	https://www.repubblica.it/green-and-blue/dossier/viaggio-al-centro-del-futuro-ok/2021/11/17/news/al-via-l-european-startup-prize-for-mobility-326498609/
Linkiesta	Railway Renaissance Will a hydrogen train save the environment? (in Italian)	https://www.linkiesta.it/2021/09/treni-idrogeno-ambiente/
DC News	The Paris - Berlin railway route could be completed in an hour. What the European mobility of the future looks like in SF movies (in Romanian)	https://www.dcnews.ro/ruta-feroviara-paris-berlin-ar-putea-fi-facuta-intr-o-ora-cum-arata-mobilitatea-europeana-a-urmatoarelor-decenii_837594.html
Jutarnji	The Trans-European Express starts on September 2, it will stop in more than 100 places and cities, this is when it is in Croatia (in Croatian)	https://novac.jutarnji.hr/novac/next/transeuropski-ekspres-krece-2-rujna-stat-ce-u-vise-od-100-mjesta-i-gradova-evo-kada-je-u-hrvatskoj-15099100
Europa FM	European Year of Railways, celebrated with a journey of 20,000 km (in Romanian)	https://www.europafm.ro/anul-european-al-cailor-ferate-celebrat-printr-o-calatorie-de-20-000-km/

Quality travel	European Year of Railways: the Connecting Europe Express starts (in Italian)	https://www.qualitytravel.it/anno-europeo-delle-ferrovie-parte-il-connecting-europe-express/99481
Kathimerini	A train station for the connection of European states (in Greek)	https://www.kathimerini.gr/society/561485977/ena-treno-stathmos-gia-ti-syndesi-eyropaikon-kraton/
kurzy.cz	European Year of Railways: The "Connecting Europe Express" train leaves the station (in Czech)	https://www.kurzy.cz/zpravy/607999-evropsky-rok-zeleznice-vlak-connecting-europe-express-vyjizdi-ze-stanice/
Salzburger Nachrichten	Special train "Connecting Europe Express" makes a stop in Vienna (in German)	https://www.sn.at/wirtschaft/oesterreich/sonderzug-connecting-europe-express-macht-station-in-wien-109285216
Yahoo noticias	Paris - Berlin in an hour: welcome to the future of high-speed rail in Europe (in Spanish)	https://es.noticias.yahoo.com/par%C3%ADs-berl%C3%ADn-hora-bienvenido-futuro-104939489.html?guccounter=1&guce_referrer=aHR0cHM6Ly93d3cuZ29vZ2xlLmNvbS8&guce_referrer_sig=AQAAAGUP41gcbtJSfH0V3A8M_gtIJJKGPRCrPx0X9nyfDkhYTvFgdBFebDmwdgsXbyiQMAoasYBy5y9zq5KGHAdOWzoi4EBf10K4EMcDGTK9py_sHuj-s8YVvVWNvNc5Gm6DYo0g0XYxP4Uv4q0YAVDRrv_hhh3xmAzVVIISJcjcw0xoi
Inter Empresas	The '4SECURail' project successfully completes its initial work to strengthen cybersecurity and improve signaling systems on European railways (in Spanish)	https://www.interempresas.net/Ferrocarril/Articulos/325761-proyecto-4SECURail-termina-satisfactoriamente-trabajo-inicial-reforzar-ciberseguridad.html
trojmiasto	From Lisbon through Gdańsk to Paris. A unique train at the main station (in Polish)	https://www.trojmiasto.pl/wiadomosci/Z-Lizbony-przez-Gdansk-do-Paryza-Wyjatkowy-pociag-na-dworcu-glownym-n159756.html
Le Lézard	Indra is about to take the plunge in Paris and revolutionize the payment of transport in the French capital (in French)	https://www.lelezard.com/communiquer-19840448.html
Monitor	In 5 weeks, the "Connection with Europe" express travels around 100 cities (in Bulgarian)	https://www.monitor.bg/bg/a/view/za-5-sedmici-ekspres-vryzka-s-evropa-obikalja-100-grad-a-280431
El Nacional	Indra receives the National Innovation Award in the category of large company (in Catalan)	https://www.elnacional.cat/ca/economia/economia-indra-rep-premi-nacional-innovacio_618686_102.html
Planète Business	Indra, the technology that opens the door to 21st century transport (in French)	https://www.planete-business.com/2021/06/07/indra-technologie-transports/
TU Graz	Railway System: Styria as International Centre of Research & Innovation	https://www.tugraz.at/en/tu-graz/services/news-stories/media-service/singleview/article/die-zukunft-auf-schienen-gesamtsystem-bahn-die-steiermark-als-internationales-forschungs-und-innovat/

TU.no	Heavy railway investment in the EU - Norway is underway (in Norwegian)	https://www.tu.no/artikler/tung-jernbanesatsing-i-eu-norge-sitter-pa-gangen-br/506253
Teknisk Ukeblad	Believe in the 30-minute hyperloop between Oslo and Stockholm - can happen before the decade is over (in Norwegian)	https://www.tu.no/artikler/tror-pa-30-minutters-hyperloop-mellom-oslo-og-stockholm-kan-skje-innen-tiaret-er-omme/513473
Ethnos	European Railway Year: Train launches to connect 26 European countries (in Greek)	https://www.ethnos.gr/ellada/172390_eyropaiko-etos-sidirodromon-xekinise-treno-poy-tha-enosei-26-eyropaikes-hores
Economic.bg	Europe is on track to achieve its railway ambitions (in Bulgarian)	https://www.economic.bg/bg/a/view/jelezopynite-ambicii-na-evropa
Parlamentní Listy	Ministry of Transport: The European Train presents the importance and possibilities of railway development (in Czech)	https://www.parlamentnilisty.cz/zpravy/tiskovezpravy/Ministerstvo-dopravy-Evropsky-vlak-prezentuje-vyznam-a-moznosti-rozvoje-zeleznice-677861
MetaforessPress	The European project MyTrac, innovation and the contribution of HIT / CERTH (in Greek)	https://www.metaforesspress.gr/mesa-mazikis-metaforas/%CF%84%CE%BF-%CE%B5%CF%85%CF%81%CF%89%CF%80%CE%B1%CF%8A%CE%BA%CF%8C-%CE%AD%CF%81%CE%B3%CE%BF-mytrac-%CE%B7-%CE%BA%CE%B1%CE%B9%CE%BD%CE%BF%CF%84%CE%BF%CE%BC%CE%AF%CE%B1-%CE%BA%CE%B1%CE%B9-%CE%B7/
Carris	CARRIS participates in Shift2MaaS (in Portuguese)	https://www.carris.pt/descubra/noticias/carris-participa-no-shift2maas-projeto-piloto-de-mobilidade/
News to the Minute	European Year will have railroad as a fundamental instrument of the Ecological Pact (in Portuguese)	https://www.noticiasominuto.com/mundo/1719576/ano-europeu-tera-ferrovia-como-instrumento-fundamental-do-pacto-ecologico
Samferdsel	Hyperloop – lightning-fast travel for people and goods (in Norwegian)	https://samferdsel.toi.no/meninger/hyperloop-lynrask-reise-for-mennesker-og-varer-article34856-677.html
ITespresso Spain	Indra brings together more than 700 young people to participate in a project on the future of transport and defense (in Spanish)	https://www.itespresso.es/indra-reune-a-mas-de-700-jovenes-para-participar-en-un-proyecto-sobre-el-futuro-del-transporte-y-la-defensa-232583.html
Gudok	OPZHT and UNIFE held a videoconference on unmanned railway technologies (in Russian)	https://gudok.ru/news/?ID=1554722
Pais Positivo	Trains: The backbone of mobility (In Portuguese)	https://sol.sapo.pt/especiais/e_paispositivo/paispositivo.pdf?fbclid=IwAR2VlrC013iZwPBE00_rN2UbmmUWH1-1Ago-DYLwvRGIS6vQYbE0God5hXU
Trasporto Europa	Railways lagging behind on cybersecurity, but with projects underway (in Italian)	https://www.trasporto.europa.it/notizie/ferrovia/ferrovie-in-ritardo-su-cybersicurezza-ma-con-progetti-in-corso/
Europa Today	Train instead of plane? In Europe, the alternative already	https://europa.today.it/ambiente/treno-aereo-europa-alternativa.html

	exists for 81 million passengers (in Italian)	
Hällekiskuriren	Record-breaking freight trains are tested between Germany and Sweden (in Swedish)	https://www.hallekis.com/xx210417a.htm
El Español	In search of the European unity to guarantee the security in the digitalization of the train (in Spanish)	https://www.elespanol.com/invertia/disruptores-innovadores/innovadores/20210409/busca-unidad-europea-garantizar-seguridad-digitalizacion-tren/571943122_0.html
Construction Cayola	Ermewa fait sa part pour changer le monde (in French)	https://www.constructioncayola.com/rail/article/2021/05/20/134447/ermewa-fait-part-pour-changer-monde
Mreza	EGNOS and Galileo on the ambitious Digital Rail program (in Croatian)	https://mreza.bug.hr/egnos-i-galileo-na-ambicioznom-programu-digital-rail/
Järnvägsnyheter .se	The Swedish Transport Administration is shifting its commitment to Europe's Railways (in Swedish)	https://www.jarvagssnyheter.se/20210511/11904/trafikverket-vaxlar-upp-engagemanget-europas-jarnvag
El canal	J. del Moral, general manager of Renfe Goods: "We need a decisive change in the dominant logistics model" (in Spanish)	https://www.diarioelcanal.com/j-del-moral-director-general-de-renfe-mercancias-necesitamos-un-cambio-decisivo-en-el-modelo-logistico-dominante/

EXTERNAL EVENTS PARTICIPATED TO BY THE JU IN 2021

In 2021, the JU participated to major events across Europe and beyond, presenting concrete results achieved by JU Members together with other key stakeholders.

European Start Up Prize for Mobility Grand Ceremony - 13 January 2021, online

The Executive Director was part of the jury for the European Startup Prize for Mobility 3rd Edition Final Ceremony. Along with special guests Maroš Šefčovič (European Commission Vice-President), Lilyana Pavlova (Vice-President of the European Investment Bank) and Karima Delli (Chair of the European Parliament's Committee on Transport and Tourism).

S2R helped select the most innovative start-ups working on the mobility solutions of tomorrow and encouraged more start-ups to start working on rail-related solutions.

Vilnius Greentech Forum - 26 January 2021, online

The Executive Director discussed how transforming Europe's rail can help us achieve a climate-neutral society.

Portugal Railway Summit – 2-3 February 2021, online

The Executive Director spoke about the advantages of participating to S2R and the future of rail in Europe.

European Shippers' Council- Rail Transport Council Meeting – 8 February 2021, online

S2R Head of R&I spoke about how to increase capacity of rail freight and improve its efficiency.

UIC Railway Noise Days – 23-24 February 2021, online

S2R Programme Manager covering Cross-Cutting Activities across our R&I programme, participated to the UIC Railway Noise Days on 24 February. She talked about JU solutions contributing to noise and vibration mitigation.

The workshop was an opportunity to provide an update on the most important issues and developments in the field of railway noise as well as discuss next steps with relevant stakeholders.

10th International Railway Summit – 23-26 February, online

JU played an active role at the 10th International Railway Summit, moderating three interesting sessions.

The Executive Director moderated two sessions devoted to the passenger experience. The first on “Designing a smoother and quieter passenger experience”, took place on 23 February and the second panel discussing “Passenger-friendly multimodal ticketing” took place on 25 February.

S2R Head of Research and Innovation moderated a third panel titled “The power of sustainability: attracting freight customers to rail” on 25 February.

SPARK-H – 23-24 February, online

The Executive Director participated to SPARK-H hydrogen event on 24 February. He explained how innovative hydrogen technologies can be beneficial for the rail industry and how they can play a key role in the decarbonisation of many areas of transport.

Webinar on the status of automatic train operation in Europe and in Russia – 26 February, online

The Executive Director spoke about our work in the field of ATO, with a particular focus on IP2.

METRANSLOG – 9 March 2021, online

JU participated to METRANSLOG - Middle East Transport & Logistics Summit on 9 March to present ‘From research to innovation: How to deliver rail transformation for social-economic benefit’.

The two-day event brought together local, regional and international participants to share best practices, trends and innovations.

EuroRail Hub – 25 March 2021, online

The Executive Director gave a keynote speech on ‘Shift2Rail's role in the European railway of tomorrow’ during the EuroRail Hub event.

For the first time, Raitex, Infrarail, SIFER and EXPO Ferroviaria launched a united digital event with the aim to support the recovery of the European rail market through interactive digital networking opportunities.

JU at UNECE workshop – 26 March 2021, online

On 26 March, our Executive Director, Mr Borghini, participated to a UNECE workshop on physical climate change risks in transport.

During the workshop experts on climate change and inland transport helped develop guidance aimed at the needs of transport professionals.

JU ATO over ETCS webinar – 30 March, online

The webinar organised by our Innovation Programme 2 and Innovation Programme 5 projects X2RAIL1, X2RAIL3 & ARCC explored the collaborative approach to Automatic Train Operation (ATO) development and presented results from two trials undertaken on an operational railway in the UK and Switzerland in 2020.

The Executive Director participated in the event along with other ATO experts, including suppliers, infrastructure managers and operators on 30 March.

ERCI Webinar on ERRAC SRIA and future perspectives of rail research (part of the European Rail Systems Technology Week (#ERSTW) – 14 April 2021, online

The Executive Director participated in a workshop organised by the European Railway Clusters Initiative (ERCI). The workshop explored future research perspectives in the rail sector under the European Union's research and innovation framework programme, Horizon Europe.

P&T Innovation Week – 27-30 April 2021, online

S2R participated in the Innovation Week organised by our Associated Member Plasser & Theurer. The conference featured a digital showroom and focused on a range of services offered for Machine Fleet Infrastructure.

S2R Executive Director, Head of Research & Innovation and Innovation Programme 3 Manager, presented JU's mission and innovations, including the innovative grinding machine developed by Plasser & Theurer within Shif2Rail.

Unife - Boosting railway digitalisation thanks to EU Research and Innovation – 27 April 2021, online

The Executive Director participated in an expert discussion on how rail can use emerging technologies to become the pioneer in sustainable mobility on 27 April.

Organised by UNIFE, as part of the European Year of Rail campaign, the event highlighted the importance of close cooperation with the European institutions for the success of research and innovation in the rail sector.

Transport Logistic – 4-6 May 2021, online

The Executive Director talked about how digitalization and automation shape the shift to rail.

Eurobrake Railways Day – 17-21 May 2021, online

The Executive Director participated in discussion on ATO oriented braking development in JU.

Digital PRIME meeting – 20 May 2021, online

S2R Head of R&I presented the S2R outputs in particular related to TMS and on CDM.

UNIFE Webinar - Innovative Rail for Sustainable Mobility – 28 May 2021, online

The Executive Director participated to the UNIFE webinar on “Innovative Rail for Sustainable Mobility” on 28 May. He discussed how rail innovation is crucial for the fulfilment of several of the Sustainable Development Goals (SDGs).

The webinar was held in the framework of the OECD International Transport Forum (ITF).

JU at RIAMS Conference – 9 June 2021, online

S2R head of R&I Giorgio Travaini participated in the RIAMS - strategic operator management keynote panel – presenting the S2R programme view contributing to the strategies for organizational change to accelerate the pace of digital transformation in rail.

JU at APTA-UITP Rail Conference – 8-9 June 2021, online

The Executive Director Carlo Borghini participated in the APTA-UITP virtual conference as a panellist in the closing plenary session “The state of rail today and where we are heading”.

This two-day virtual technical conference, organised by APTA and UITP on 8-9 June, featured sessions covering multiple aspects of the rail sector, and explored different rail modes such as high-speed and urban transport.

Rail Infrastructure Asset Management Summit – 9 June 2021, online

S2R Head of R&I joined the Strategic Operator Management Keynote Panel at the Rail Infrastructure Asset Management Summit on 9 June.

During the panel he spoke about ‘Strategies for Organisational Change to Accelerate the Pace of Digital Transformation in Rail: Everything is Related to Management’.

IPIC – 15 June 2021, online

JU participated in a panel on ‘The fifth transport mode: state of play 2021’ at the 8th International Physical Internet Conference (IPIC 2021) on 15 June. During the event The Executive Director discussed the development of tube transport, pipelines and hyperloop.

The conference provided an open forum for participants from all over the world to discuss global logistics efficiency and sustainability.

Scandinavian Rail Optimisation Online Conference – 24 June 2021, online

The Executive Director spoke about how JU delivers the capabilities to bring about sustainable, cost-efficient, high-performing, time driven, digital and competitive customer-driven railways for Europe at the Scandinavian Rail Optimisation Online Conference on 24 June.

Western Balkan Rail Summit – 13 September 2021, Belgrade

The Executive Director moderated the Rail Infrastructure panel at the Western Balkan Rail Summit on 13 September.

The summit, organised by the Transport Community, celebrated the European Year of Rail and focused on the integration of the Western Balkans rail system with the EU rail system.

Digital Rail Revolution 2021 – 16 September 2021, online

The Executive Director moderated a panel discussion at the Digital Rail Revolution conference on 16 September.

The panel titled 'Next steps in delivering digital automatic coupling (DAC)' discussed how DAC can help to grow rail freight and shift more goods onto tracks.

Rail Broadcast Week 2021 – 13-16 September 2021, online

S2R sponsored a panel discussion as part of Railway Gazette's Rail Broadcast Week 2021 on 13-16 September.

The Executive Director spoke about the future of Digital Automatic Coupling in Europe with representatives of the International Union of Wagon Keepers and ÖBB.

International Mobility Congress – 22 September 2021, Sitges

S2R Head of Research and Innovation participated in a round-table at the International Mobility Congress.

The session 'Mobility and European funds, Strategies and Opportunities' on 22 September addressed mobility strategies post-Covid and in the context of the Sustainable Development Goals.

TRAKO – 22 September 2021, Gdansk

The Executive Director participated in a debate on 'New technologies, new solutions for the railways' at the International Railway Fair TRAKO 2021 on 22 September.

TRAKO is Poland's largest railway fair dedicated to transport systems and railway infrastructure in Europe and around the globe.

DITECFER Railway Innovation Prize Ceremony – 29 September 2021, online

Against the backdrop of Expo Ferroviaria, S2R Head of Research and Innovation participated to a conference on 'The Modularisation of Railway Systems', organised in collaboration with DITECFER. The conference introduced the 'revolution' in the railway sector brought forward thanks to the work done by JU research and innovation projects.

During the event, he also awarded the prize for the 7th DITECFER Railway Innovation Contest at EXPO Ferroviaria on 29 September.

World Passenger Festival – 5 October 2021, Amsterdam

S2R Head of Research and Innovation participated in a session “Giving the power to our customers: how can digital transformation support a shift to shared and public mobility?” at the World Passenger Festival on 5 October.

The World Passenger Festival in Amsterdam brings together transport leaders to discuss sustainable travel, integrated mobility and customer experience to encourage the use of transport among the general public.

Alpine Rail Optimisation – 6 October 2021, Vienna

During the Conference, on 6 October, S2R Head of Research and Innovation gave a speech titled: “On the way to a new Rail Research and Innovation Programme” in which he spoke about building the European future rail concept of operations, what to expect from rail research and innovation during the next years, and migration plans in a view of deployment.

GRITLAB – 7 October 2021, Graz

S2R Head of Research and Innovation gave a keynote speech on railway game changer technologies and their impact at the Graz Railway Intelligence Tech Lab in Graz on 7 October.

The event offered masterclasses on pressing topics of the industry, such as digital twin turnouts, switches and crossings, digital twin bogies and digital twin deployment.

Connecting Europe Facility Support for Railways – 14 October 2021, online

The Executive Director spoke at the Connecting Europe Facility Support for Railways event as a panellist during a discussion titled “CEF contribution to the Single European Railway Area (SEPA)”.

This event illustrated how CEF has played a key role in the mobilisation of the necessary resources to the successful completion of projects and how these projects have contributed to the provisions of better services to the final users.

European Year of Rail Event in Vienna – 18 October 2021, Vienna

On 18 October during the European Year of Rail Event in Vienna, The Executive Director presented the achievements of JU and the upcoming activities of our successor programme, Europe's Rail.

The aim of the event was to highlight innovative solutions for the environmentally friendly transport mode of rail for sustainable European passenger and freight mobility.

Transport and Logistics 2050 – 21 October 2021, online

The Executive Director delivered an online presentation on 21 October titled "Towards a climate-neutral society: the transformation of the railways".

This international event for transport and logistics presented the latest technological solutions and political issues that will become an essential condition for a competitive business of the future.

Rail Asset Management in Europe – 27 October 2021, online

S2R Innovation Programme 3 Manager, spoke at the Rail Asset Management in Europe conference, about the new Europe's Rail programme, building European intelligent asset management systems, and the outcomes from rail research and innovation in the next few years on October 27.

The conference featured a mix of panel discussions and presentations addressing, among other things, the needs of existing urban rail systems, systems undergoing upgrade or renewal as well as upcoming systems.

SIFER - 26-28 October 2021, Lille

JU took part in SIFER, France's largest rail industry event, in Lille on 26-28 October.

Visitors, including high level representatives from UNIFE and European Commission's Directorate for Internal Market, Industry, Entrepreneurship and SMEs, had the opportunity to meet JU colleagues and take a look at some of our most recent innovative solutions.

S2R Innovation Programme 2 Manager participated to a panel on Europe's Rail objectives and ideas for boosting the EU railway industry with research and development.

Hypermotion Dubai – 2-4 November 2021, online

The Executive Director virtually participated to Hypermotion Dubai. During his intervention, Mr Borghini talked about some of JU success stories, Europe's Rail programme, and how can we expect to see the European rail network evolve over the next decade.

Future of Mobility Forum in Dubai – 3 November 2021, online

The Executive Director participated in a panel discussion at the Shaping the Future of Mobility forum in Dubai discussing "Rail as backbone of multimodality and sustainability in transport" on 3 November.

The Forum highlighted the principles of Sustainable Development, to plan, design and build infrastructures of a more modern, competitive, and resilient country, in line with the principles of the UN 2030 Agenda, the European Green Deal and Italy's National Recovery and Resilience Plan.

Shaping the Future of Mobility – 10-12 November 2021, Lisbon

The Executive Director participated to a panel discussion titled "Innovation and technical challenges of the European transport system" at the Shaping the Future of Mobility seminar on 11 November.

Shaping the Future of Mobility is an international seminar included in the European Year of Rail programme, that took place in Lisbon on 10-12 November.

Belgian Rail Day – 17 November 2021, online

The Executive Director joined a discussion on rail research and innovation at the Belgian Rail Day on 17 November, along with high-level speakers such as the European Commissioner for Transport Adina Valean, Director-General for Mobility and Transport, Henrik Hololei, and the Belgian Minister of Mobility, Georges Gilkinet.

The Belgian Rail Day was co-organised by Europalia, Agoria and FEB. During the colloquium, the speakers discussed Europe's rail ambitions and Belgium's response to the challenges facing the sector.

InnoRail – 16-18 November 2021, Budapest

The Executive Director delivered a video message at InnoRail2021 on 16-18 November, discussing Europe's Rail, Shift2Rail achievements, and the EU DAC Delivery Programme.

Additionally, Vice Chairperson of Shift2Rail's States Representatives Group, gave a speech titled "Rail system as a backbone of mobility".

The InnoRail conference is committed to rail transport with the objective of thinking together about the present of rail transport and fostering its future development.

PTFE General Assembly – 17 November 2021, online

S2R Head of Research and Innovation participated to the PTFE General Assembly on 17 November. Within the framework of the European Year of Rail, the PTFE focused its debate on national and international R&D&I strategies, the instruments to support the sector and disruptive innovation vectors.

IRSA – 22 November 2021, online

On 22 November, The Executive Director gave a keynote speech on JU's successor, Europe's Rail during the International Railway Symposium Aachen 2021.

During this hybrid event, an international framework for interdisciplinary exchange between industry, science and politics on current and future rail transport topics from research and practice, was provided.

EU for Smart Mobility – 24 November 2021, Warsaw

On 25 November, The Executive Director gave a keynote speech on environmentally friendly transport systems in Europe at the EU for Smart Mobility conference.

He also participated in a panel focused on environmentally friendly solutions such as electromobility, hydrogen mobility and current and future trends and patterns to achieve zero emission in transport.

The conference took place in Warsaw on 25-26 November 2021, and it was organized by the Centre for EU Transport Projects, a governmental entity responsible for implementing EU co-financed transport projects.

Conferenza ASSTRA "La rivoluzione dell'idrogeno nel trasporto ferroviario" – 24 November 2021, Milano

On 25 November, S2R head of R&I gave a keynote speech on R&I activities for rail transport with hydrogen power carrier. The meeting was organised with the support of Lombardia region and several other Italian regions expressed the interest to undertake hydrogen rail related transport activities.

RailLive! – 30 November – 1 December 2021, Madrid

S2R had a stand at RailLive in Madrid on 30 November – 1 December where visitors could learn more about JU's Innovation Programmes and our future as Europe's Rail.

On 1 December, our Executive Director took part at the “Investing in, designing and building the rail networks which will provide a connected backbone for mobility of tomorrow” panel. He also delivered a presentation about “Meeting the conditions to double rail freight across Europe by 2030 with digitisation”.

A presentation on “Designing, testing and implementing the critical control systems of the future” was given by S2R Head of Research and Innovation.

During the event, the Minister of Development, Infrastructures and Regional Planning of the Junta de Andalucía, Marifran Carazo, and the Mayor of Malagá, visited our stand and discussed with The Executive Director on a possible collaboration with the region.

Second Smart Rail Technology Conference – 30 November 2021, online

The Executive Director took part in a panel titled “HYDRAIL: Strategic economic and environmental drivers behind the hydrail phenomenon” on 30 November.

CUTRIC hosted its second Smart Rail Technology Conference virtually on November 30 – December 1 to discuss critical topics that will define the future of rail in Canada.

UIC Symposium – 30 November 2021, online

The Executive Director participated to a panel on “Digital game changers in the next 5 years?” and talked about the transition to clean mobility at the UIC Symposium 2021 on 30 November.

UIC held a symposium on The Future of the Railways: Making Modal Shift Desirable on 30 November - 1 December at its headquarters in Paris.

UNIFE webinar “Enabling digital and intelligent rail freight in Europe” – 7 December 2021, online

The Executive Director highlighted the need to focus on emerging technologies at the UNIFE webinar “Enabling digital and intelligent rail freight in Europe” on 7 December.

Organised by UNIFE as part of “The European Year of Rail” campaign, this event was an opportunity to assess the importance of rail freight for reaching the European Commission’s climate and digitalisation targets with high level representatives from the European Parliament, the European Union Agency for Railways (ERA), Siemens Mobility and Wabtec.

ICT for Railway workshop in – 7 December 2021, Toulouse

S2R Cross-Cutting Activities Manager participated to a panel discussion on Strengthening European Railway Competitiveness at the ICT for Railway workshop in Toulouse, France on 7 December.

The discussion focused on the role of standardisation in innovation. Standardisation and regulatory path need to be developed in one common strategy with research in order to ensure proper and quick market uptake of solution. The Europe’s Rail System Pillar will ensure this major step-change.

SESAR Innovation Days – 8 December 2021, online

The Executive Director Carlo Borghini gave a keynote speech at the SESAR JU Innovation Days on 8 December. The SESAR Innovation Days was the main event for SESAR Joint Undertaking to share progress and disseminate exploratory research results.

ANNEX F LIST OF ACRONYMS

Abbreviation	
ABAC	Accrual Based Accounting
ADI	Austempered Ductile Iron
AO	Authorising Officer
ATO	Automated Train Operation
AWP	Annual Work Plan
AAR	Annual Activity Report
CA	Commitment Appropriation
CAS	Common Audit Service
CAPEX	Capital Expenditure
CBM	Condition-Based Maintenance
CBTC	Communication Based Train Control
CCA	Cross Cutting Activities
CEN	European Committee for Standardisation
CENELEC	European Committee for Electrotechnical Standardisation
CFM	Call for Members
Covid-19	'CO' stands for corona, 'VI' for virus, and 'D' for disease. Formerly, this disease was referred to as '2019 novel coronavirus' or '2019-nCoV.' The COVID-19 virus is a new virus linked to the same family of viruses as Severe Acute Respiratory Syndrome (SARS) and some types of common cold.
CRS	Common Representative Sample
CREL	Core Release
CSA	Coordination and support action
CW	Cloud Wallet
DOI	Digital Object Identifier
DRIMS	Dynamic Railway Information Management System
EC	European Commission
ECA	European Court of Auditors
ED	Executive Director
EDPS	European Data Protection Supervisor
EDV	Electronic Distributor Valve
EMC	Electromagnetic Compatibility
EMI	Electromagnetic Interference
EN	European Norm
ERA	European Union Agency for Railways
ERRAC	European Rail Research Advisory Council
ERTMS	European Rail Traffic Management System
ETCS	European Train Controlling System
EU	European Union
EUG	ERTMS Users Group
EU-Rail	The Europe's Rail Joint Undertaking
FACTs	Flexible AC Transmission Systems
FFFIS	Form Fit Functional Interface Specifications
FIS	Functional Interface Specifications

FREL	Final Release
GA	Grant Agreement
GDPR	General Data Protection Regulation
GIS	Geographic Information System
GNSS	Global Navigation Satellite System
GoA	Grade of Automation
H2020	Horizon 2020, EU framework programme for Research and Innovation
HST	High-Speed Train
IA	Innovation Action
IAS	Internal Audit Service
LP	Lighthouse Project
ICT	Information and Communications Technology
IEC	International Electrotechnical Commission
IKAA	in-kind contributions to additional activities
IP	Innovation Programme
IPR	Intellectual Property Rights
ISO	International Standardisation Organisation
IT	Information Technology
ITD	Integrated Technology Demonstrator
JTI	Joint Technology Initiative
JU	Joint Undertaking
KPI	Key Performance Indicator
LCC	Life Cycle Cost
LIDAR	Light Detection and Ranging
LTE	Long-Term Evolution (standard for wireless communication)
MAAP	Multi-Annual Action Plan
MaaS	Mobility as a Service
MB(S)	Moving block (System)
MC	Mission Critical
MNO	Mobile Network Operator
NaaS	Network as an Asset
NaaS	Network as a Service
NLOS	non-line-of-sight
NTP	Network Time Protocol
OC	Open Call
ODM	Operational Data Management
OMTS	On-board Multimedia and Telematics Services
OPEX	Operating Expenditure
PA	Payment Appropriation
RCA	Railway Command Control and Signalling Architecture
R&I	Research and Innovation
PPP	Public Private Partnership
PRM	Persons with Reduced Mobility
PTC	Positive Train Control
PTI	Platform Train Interface

QoA	Quality of Service
RAL	Unpaid amount
RAMS	Reliability and Maintainability System
RBC	Radio Block Centre
RFID	Radio Frequency Identification
RIA	Research and innovation action
RoI	Return of Investment
S2R	Shift2Rail
SBA	The Single Basic Act - Council Regulation (EU) 2021/2085 of 19 November 2021 establishing the Joint Undertakings under Horizon Europe
SC	Scientific Committee
SDG	Sustainable Development Goals
SETA	Single European Transport Area
SiC	Silicon Carbide
SLA	Service Level Agreement
SME	Small and Medium Enterprise
SNE	Seconded National Expert
SPD	System Platform Demonstration
SRG	States Representatives Group
SWL	Single Wagon Load
TAF	Telematic Application for Freight
TAP	Telematic Application for Passengers
TCMS	Train Control and Monitoring System
TCO	Total Cost of Ownership
TD	Technology Demonstrator
TL	Train Load
TMS	Traffic Management System
TRL	Technology Readiness Level
TSI	Technical Specifications for Interoperability
TSP	Travel Service Provider
UAV	Unmanned Aerial Vehicle
UG	User Group
UN	United Nations
WA	Work Area
WP	Work Package
WSP	Wheel Slide Protection

ANNEX G List of members pertaining to the Shift2Rail Joint Undertaking until 29/11/2021

Founding Members



Associated Members



Virtual Vehicle Austria Consortium (VVAC+)



European Rail Operating community Consortium (EUROC)



SwiTracken Consortium



Smart DeMain(SDM) Consortium



AERFITEC



Competitive Freight Wagon Consortium(CFW)



Smart Rail Control (SmartRaCon) consortium



	<ul style="list-style-type: none"> • HACON <i>Lars DEITERDING</i> • HITACHI RAIL STS <i>Antonella Trombetta</i> • INDRA <i>Javier Rivilla LIZANO</i> • KNORR - BREMSE <i>Hans-Christian HILSE</i> • NETWORK RAIL <i>Robert AMPOMAH</i> • SIEMENS <i>Roland EDEL</i> • SMARTDEMAIN <i>Henk SAMSON</i> • SMARTRACON <i>Michael Meyer zu HÖRSTE</i> • SNCF <i>Carole DESNOST</i> • THALES <i>Yves PERREAL (Industrial Spokesperson)</i> • TRAFIKVERKET <i>Bo OLSSON</i> • VVAC+ <i>Filip KITANOSKI</i> <p>Industry alternates:</p> <ul style="list-style-type: none"> • ALSTOM <i>Sophie PERROCHEAU</i> • AZD Praha <i>Michal PAVEL</i> • BOMBARDIER TRANSPORTATION <i>Richard FRENCH</i> • CAF <i>Jorge DE CASTRO</i> • DEUTSCHE BAHN <i>Ralf MARXEN</i> • EUROOC <i>(to be appointed)</i> • HACON <i>Rolf GOOßMANN</i> • HITACHI RAIL STS <i>Claudio MONTI</i> • INDRA <i>Javier Rivilla LIZANO</i> • KNORR - BREMSE <i>Jasmina BRACKOVIC</i> • NETWORK RAIL <i>Felicity OSBORN</i> • SIEMENS <i>Jürgen SCHLAHT</i> • SMARTDEMAIN <i>Javier Bonilla DÍAZ</i> • SMARTRACON <i>Jaizki MENDIZABAL</i> • SNCF <i>Christophe CHERON</i> • THALES <i>Alberto PARRONDO</i> • TRAFIKVERKET <i>Christer LOFVING</i> • VVAC+ <i>Erik STOCKER</i> <p>Other participants:</p> <ul style="list-style-type: none"> • Carlo M BORGHINI <i>Executive Director of the S2R JU</i> <p>Observers:</p> <ul style="list-style-type: none"> • Josef DOPPELBAUER (ERA) • Anna GIGANTINO(ERA) • Ny Tiana TOURNIER (ERA) • Angela DI FEBBRARO (SC Chair) • Sarah BITTNER-KRAUTSACK (SRG Chair) • Miroslav HALTUF (SRG Vice Chair)
Other bodies	<p>Scientific Committee (SC) States Representatives Group (SRG) Innovation Programmes' Steering Committees (IP SteCos)</p>

**Strategic Research
Agenda**

In accordance with the S2R Regulation, the strategic research and innovation agenda of the S2R JU is described in the Multi-Annual Action Plan (MAAP) adopted in its latest version in November 2019, with GB Decision N° 9/2019;

The original MAAP of 2015 is maintained as a reference document.

ANNEX I List of Founding Members of the Europe’s Rail Joint Undertaking





SHIFT2RAIL.ORG